

DIFFERENTIAL AND DRIVELINE

TABLE OF CONTENTS

	page		page
PROPELLER SHAFTS	1	198 RBI AXLE	53
TUBE AND 186 FBI AXLE	11	226 RBA AXLE	95

PROPELLER SHAFTS

TABLE OF CONTENTS

	page		page
DESCRIPTION AND OPERATION		REAR PROPELLER SHAFT	8
PROPELLER SHAFTS	1	DISASSEMBLY AND ASSEMBLY	
PROPELLER SHAFT JOINTS	2	SINGLE CARDAN UNIVERSAL JOINT	8
PROPELLER SHAFT JOINT ANGLE	2	CLEANING AND INSPECTION	
DIAGNOSIS AND TESTING		SINGLE CARDAN JOINT	10
VIBRATION	2	ADJUSTMENTS	
UNBALANCE	3	FRONT PROPELLER SHAFT MEASUREMENT ..	10
RUNOUT	5	SPECIFICATIONS	
SERVICE PROCEDURES		TORQUE	10
DRIVELINE ANGLE MEASUREMENT		SPECIAL TOOLS	
PREPARATION	5	PROPELLER SHAFT	10
PROPELLER SHAFT ANGLE MEASUREMENT ..	6		
REMOVAL AND INSTALLATION			
FRONT PROPELLER SHAFT	6		

DESCRIPTION AND OPERATION

PROPELLER SHAFTS

DESCRIPTION

A propeller shaft (Fig. 2) is the shaft which connects the transmission/transfer case to the axle differential. This is the link through which the engine power is transmitted to the axle.

The propeller shaft is designed and built with the yoke lugs in line with each other which is called zero phasing. This design produces the smoothest running condition, an out-of-phase shaft can cause a vibration.

Tubular propeller shafts are balanced by the manufacturer with weights spot welded to the tube.

FRONT PROPELLER SHAFT

Only one style of front propeller shaft is used on WJ vehicles. The propeller shaft uses a Constant

Velocity (CV) joint at both the axle and transfer case end of the propeller shaft. The CV joint at the axle end contracts and extends (plunges) as necessary to accommodate the variations in length necessary due to suspension travel. The CV joint at the transfer case end of the propeller shaft is fixed. The two CV joints are connected by a hollow tube shaft. The shaft length is not adjustable and does vary according to application.

PRECAUTIONS

Use the exact replacement parts when installing the propeller shafts. The use of the correct replacement parts helps to ensure safe operation. All fasteners must be torqued to the specified values for safe operation.

Also make alignment reference marks (Fig. 1) on the propeller shaft yoke and axle, or transmission, yoke prior to servicing. This helps to eliminate possible vibration.

DESCRIPTION AND OPERATION (Continued)

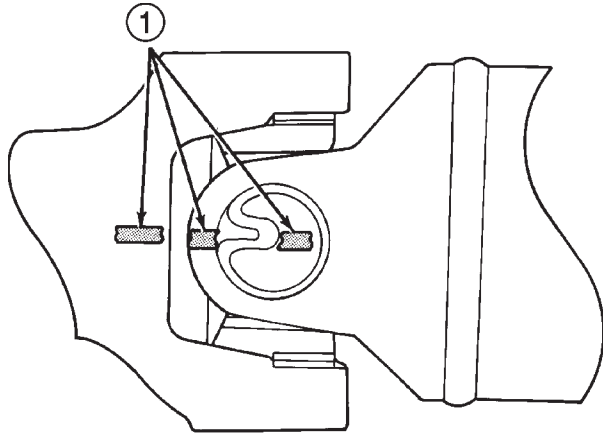

J9316-2

Fig. 1 Reference Marks on Yokes

1 - REFERENCE MARKS

CAUTION: Do not allow the propeller shaft to drop or hang from any propeller shaft joint during removal. Attach the propeller shaft to the vehicle underside with wire to prevent damage to the joints.

OPERATION

The propeller shaft must operate through constantly changing relative angles between the transmission and axle. It must also be capable of changing length while transmitting torque. The axle rides suspended by springs in a floating motion. The propeller shaft must be able to change operating angles when going over various road surfaces. This is accomplished through universal joints, which permit the propeller shaft to operate at different angles. The slip joints (or yokes) permit contraction or expansion (Fig. 2).

Before undercoating a vehicle, the propeller shaft and the U-joints should be covered to prevent an out-of-balance condition and driveline vibration.

CAUTION: Use original equipment replacement parts for attaching the propeller shafts. The specified torque must always be applied when tightening the fasteners.

PROPELLER SHAFT JOINTS**DESCRIPTION**

Two different types of propeller shaft joints are used in WJ vehicles (Fig. 3) and (Fig. 4). Neither of the joints are servicable. If worn or damaged, they must be replaced. If a vehicle has a damaged or worn Constant Velocity (CV) joint, or boot, the propeller shaft must be replaced.

LUBRICATION

The factory installed universal joints are lubricated for the life of the vehicle and do not need lubrication. All universal joints should be inspected for leakage and damage each time the vehicle is serviced. If seal leakage or damage exists, the universal joint should be replaced.

The Constant Velocity joint should also be inspected each time the vehicle is serviced. The CV joint boot is designed to last the life of the vehicle and to keep the joint lubricated. If grease leakage or boot damage is found, the propeller shaft must be replaced.

PROPELLER SHAFT JOINT ANGLE**DESCRIPTION**

When two shafts come together at a common joint, the bend that is formed is called the operating angle. The larger the angle, the larger the amount of angular acceleration and deceleration of the joint. This speeding up and slowing down of the joint must be cancelled to produce a smooth power flow.

OPERATION

This cancellation is done through the phasing of a propeller shaft and ensuring that the proper propeller shaft joint working angles are maintained.

A propeller shaft is properly phased when the yoke ends are in the same plane, or in line. A twisted shaft will make the yokes out of phase and cause a noticeable vibration.

Ideally the driveline system should have;

- Angles that are equal or opposite within 1 degree of each other.
- Have a 3 degree maximum operating angle.
- Have at least a 1/2 degree continuous operating (propeller shaft) angle.

Propeller shaft speed (rpm) is the main factor in determining the maximum allowable operating angle. As a guide to the maximum normal operating angles refer to (Fig. 5).

DIAGNOSIS AND TESTING**VIBRATION**

Tires that are out-of-round, or wheels that are unbalanced, will cause a low frequency vibration. Refer to Group 22, Tires and Wheels, for additional information.

Driveline vibration can also result from loose or damaged engine mounts. Refer to Group 9, Engines, for additional information.

Propeller shaft vibration increases as the vehicle speed is increased. A vibration that occurs within a

DIAGNOSIS AND TESTING (Continued)

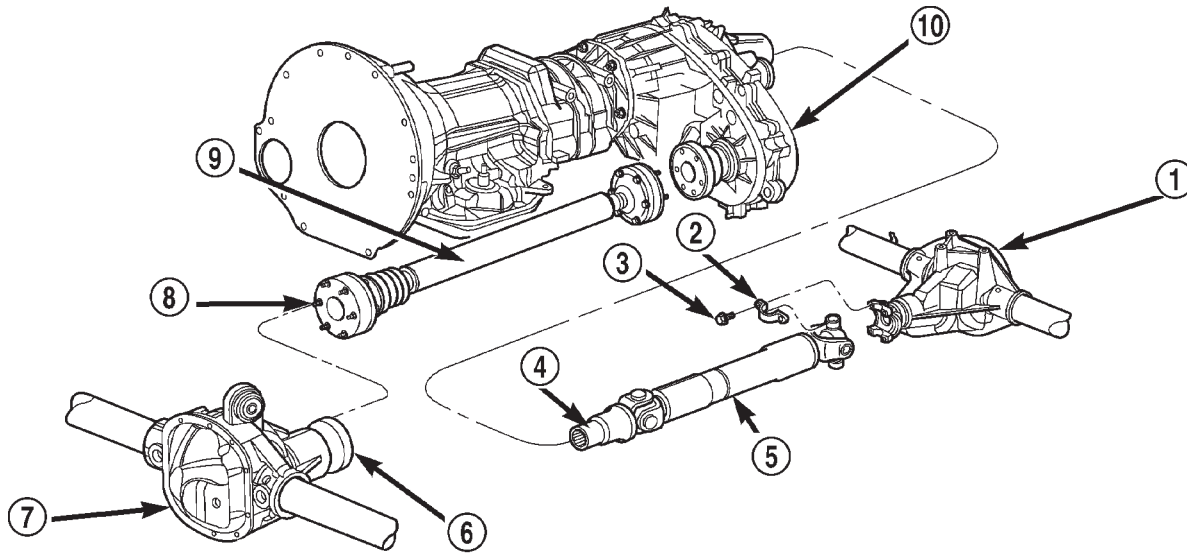

80ba79be

Fig. 2 Propeller Shafts

- | | |
|--------------------------|---------------------------|
| 1 - REAR AXLE | 6 - PINION FLANGE |
| 2 - STRAP | 7 - FRONT AXLE |
| 3 - BOLT | 8 - BOLT |
| 4 - SLIP YOKE | 9 - FRONT PROPELLER SHAFT |
| 5 - REAR PROPELLER SHAFT | 10 - TRANSFER CASE |

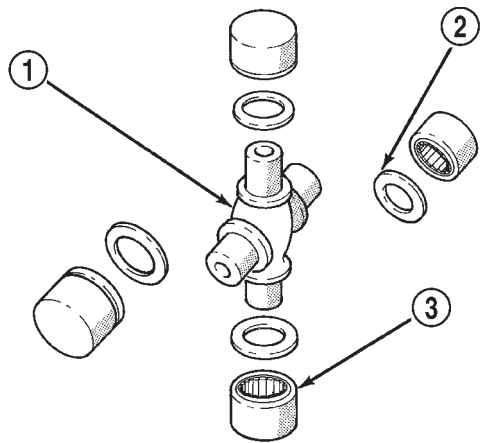

J9516-9

Fig. 3 Single Cardan U-Joint

- | |
|-----------------------------|
| 1 - CROSS |
| 2 - SEAL |
| 3 - CAP AND NEEDLE BEARINGS |

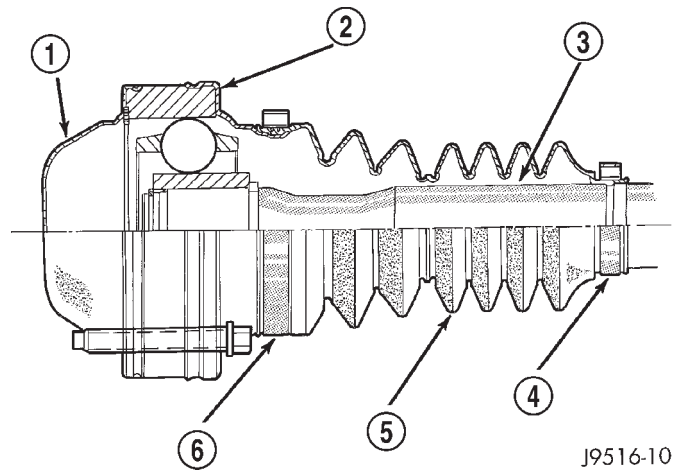

J9516-10

Fig. 4 Constant Velocity Joint

- | |
|---------------------|
| 1 - ENCLOSURE CAP |
| 2 - JOINT ASSEMBLY |
| 3 - PROPELLER SHAFT |
| 4 - BOOT CLAMP |
| 5 - BOOT |
| 6 - BOOT CLAMP |

specific speed range is not usually caused by a propeller shaft being unbalanced. Defective universal joints, or an incorrect propeller shaft angle, are usually the cause of such a vibration.

UNBALANCE

NOTE: Removing and re-indexing the propeller shaft 180° relative to the yoke may eliminate some vibrations.

If propeller shaft is suspected of being unbalanced, it can be verified with the following procedure:

- (1) Raise the vehicle.
- (2) Clean all the foreign material from the propeller shaft and the universal joints.

DIAGNOSIS AND TESTING (Continued)

PROPELLER SHAFT R.P.M.	MAX. NORMAL OPERATING ANGLES
5000	3°
4500	3°
4000	4°
3500	5°
3000	5°
2500	7°
2000	8°
1500	11°

(8) Run and accelerate the vehicle until vibration occurs. Note the intensity and speed the vibration occurred. Stop the engine.

(9) Install a screw clamp at position 1 (Fig. 6).

(10) Start the engine and re-check for vibration. If there is little or no change in vibration, move the clamp to one of the other three positions. Repeat the vibration test.

(11) If there is no difference in vibration at the other positions, the source of the vibration may not be propeller shaft.

(12) If the vibration decreased, install a second clamp (Fig. 7) and repeat the test.

(13) If the additional clamp causes an additional vibration, separate the clamps (1/4 inch above and

Fig. 5 Maximum Angles And Propeller Shaft Speed

DRIVELINE VIBRATION

Drive Condition	Possible Cause	Correction
PROPELLER SHAFT	a. Undercoating or other foreign material on shaft. b. Loose U-joint clamp screws. c. Loose or bent U-joint yoke or excessive runout. d. Incorrect drive line angularity. e. Rear spring center bolt not in seat. f. Worn U-joint bearings. g. Propeller shaft damaged (bent tube) or out of balance. h. Broken rear spring. i. Excessive runout or unbalanced condition. j. Excessive drive pinion gear shaft yoke runout.	a. Clean exterior of shaft and wash with solvent. b. Tighten screws properly. c. Install replacement yoke. d. Correct angularity. e. Loosen spring U-bolts and seat center bolts. f. Replace U-joint. g. Install replacement propeller shaft. h. Replace rear spring. i. Reindex propeller shaft 180°, test and correct as necessary. j. Reindex propeller shaft 180° and evaluate.
UNIVERSAL JOINT NOISE	a. U-joint clamp screws loose. b. Lack of lubrication.	a. Tighten screws with specified torque. Replace U-joint.

(3) Inspect the propeller shaft for missing balance weights, broken welds, and bent areas. **If the propeller shaft is bent, it must be replaced.**

(4) Inspect the universal joints to ensure that they are not worn, are properly installed, and are correctly aligned with the shaft.

(5) Check the universal joint clamp screws torque.

(6) Remove the wheels and tires. Install the wheel lug nuts to retain the brake drums or rotors.

(7) Mark and number the shaft six inches from the yoke end at four positions 90° apart.

below the mark). Repeat the vibration test (Fig. 8).

(14) Increase distance between the clamp screws and repeat the test until the amount of vibration is at the lowest level. Bend the slack end of the clamps so the screws will not loosen.

(15) If the vibration remains unacceptable, apply the same steps to the front end of the propeller shaft.

(16) Install the wheel and tires. Lower the vehicle.

DIAGNOSIS AND TESTING (Continued)

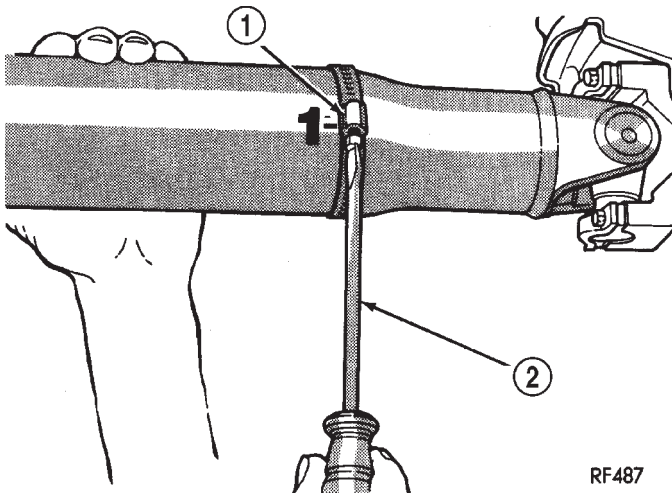

RF487

Fig. 6 Clamp Screw At Position 1

- 1 - CLAMP
- 2 - SCREWDRIVER

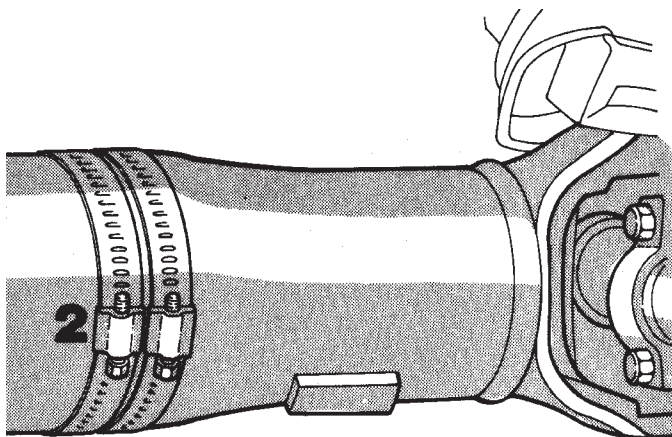

RF488

Fig. 7 Two Clamp Screws At The Same Position

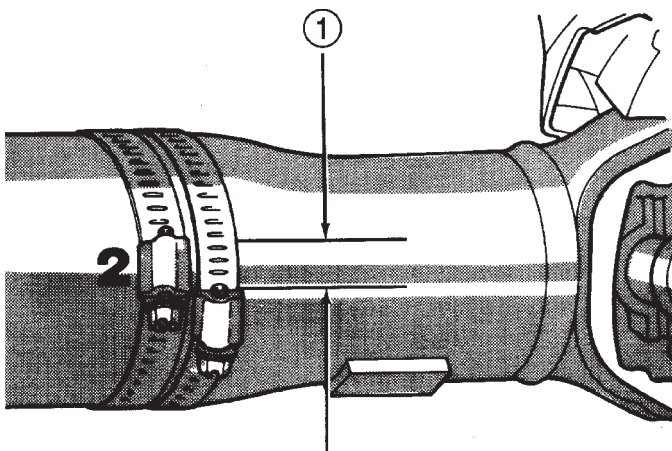

RF489

Fig. 8 Clamp Screws Separated

- 1 - 1/2 INCH

RUNOUT

(1) Remove dirt, rust, paint, and undercoating from the propeller shaft surface where the dial indicator will contact the shaft.

(2) The dial indicator must be installed perpendicular to the shaft surface.

(3) Measure runout at the center and ends of the shaft sufficiently far away from weld areas to ensure that the effects of the weld process will not enter into the measurements.

(4) Refer to Runout Specifications chart.

(5) If the propeller shaft runout is out of specification, remove the propeller shaft, index the shaft 180°, and re-install the propeller shaft. Measure shaft runout again.

(6) If the propeller shaft runout is now within specifications, mark the shaft and yokes for proper orientation.

(7) If the propeller shaft runout is not within specifications, verify that the runout of the transmission/transfer case and axle are within specifications. Correct as necessary and re-measure propeller shaft runout.

(8) Replace the propeller shaft if the runout still exceeds the limits.

RUNOUT SPECIFICATIONS

Front of Shaft	0.020 in. (0.50 mm)
Center of Shaft	0.025 in. (0.63 mm)
Rear of Shaft	0.020 in. (0.50 mm)
Measure front/rear runout approximately 3 inches (76 mm) from the weld seam at each end of the shaft tube for tube lengths over 30 inches. For tube lengths under 30 inches, the maximum allowed runout is 0.020 in. (0.50 mm) for the full length of the tube.	

SERVICE PROCEDURES

DRIVELINE ANGLE MEASUREMENT PREPARATION

Before measuring universal joint angles, the following must be done;

- Inflate all tires to correct pressure.
- Check the angles in the same loaded or unloaded condition as when the vibration occurred. Propeller shaft angles change according to the amount of load in the vehicle.
- Check the condition of all suspension components and verify all fasteners are torqued to specifications.
- Check the condition of the engine and transmission mounts and verify all fasteners are torqued to specifications.

SERVICE PROCEDURES (Continued)

PROPELLER SHAFT ANGLE MEASUREMENT

To accurately check driveline alignment, raise and support the vehicle at the axles as level as possible. Allow the wheels and propeller shaft to turn. Remove any external bearing snap rings, if equipped, from universal joint so that the inclinometer base sits flat.

The same basic procedure applies to both the front propeller shafts and the rear propeller shaft. To obtain the front (output) angle on the CV front propeller shaft, the inclinometer is placed on the machined ring of the pinion flange. To obtain the propeller shaft angle measurement on the CV front propeller shaft, the inclinometer is placed on the propeller shaft tube.

(1) Rotate the shaft until transmission/transfer case output yoke bearing cap is facing downward, if necessary.

Always make measurements from front to rear.

(2) Place Inclinometer on yoke bearing cap, or the pinion flange ring, (A) parallel to the shaft (Fig. 9). Center bubble in sight glass and record measurement.

This measurement will give you the transmission or Output Yoke Angle (A).

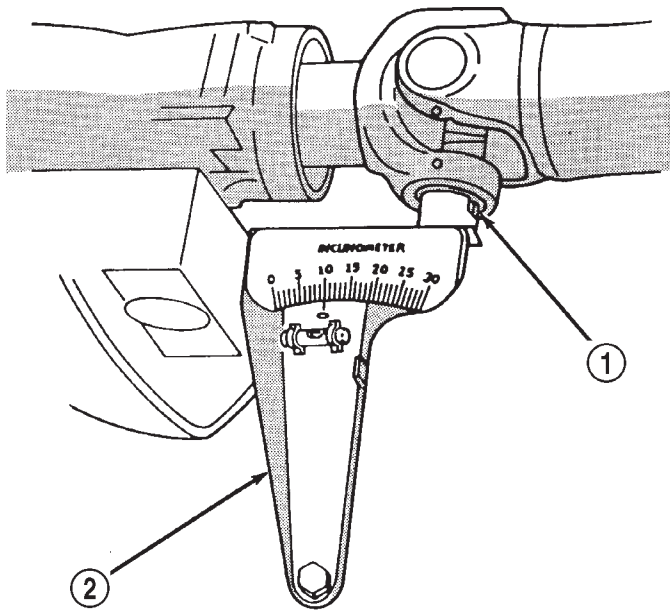

J9216-13

Fig. 9 Front (Output) Angle Measurement (A)

- 1 - SLIP YOKE BEARING CAP
2 - SPECIAL TOOL 7663 (J-23498A)

(3) Rotate propeller shaft 90 degrees and place Inclinometer on yoke bearing cap, or propeller shaft tube on CV propeller shaft, parallel to the shaft (Fig. 10). Center bubble in sight glass and record measurement. This measurement can also be taken at the rear end of the shaft.

This measurement will give you the propeller shaft angle (C).

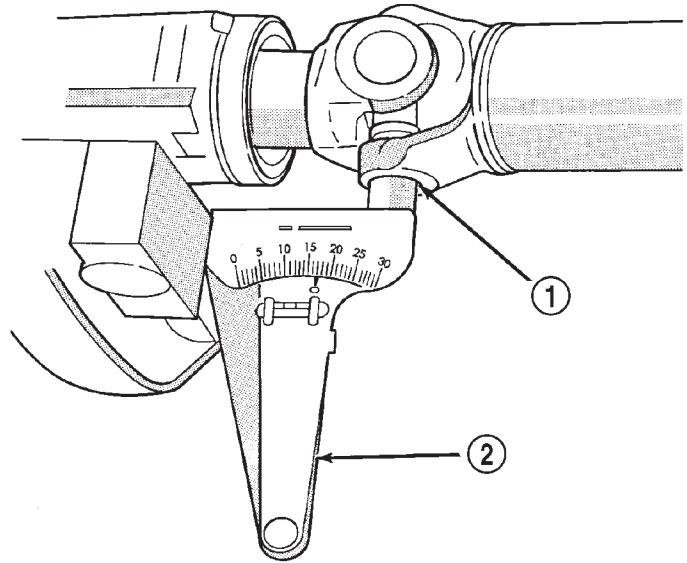

J9216-9

Fig. 10 Propeller Shaft Angle Measurement (C)

- 1 - SHAFT YOKE BEARING CAP
2 - SPECIAL TOOL 7663 (J23498-A)

(4) Subtract smaller figure from larger (C minus A) to obtain transmission output operating angle.

(5) Rotate propeller shaft 90 degrees and place Inclinometer on pinion yoke bearing cap parallel to the shaft (Fig. 11). Center bubble in sight glass and record measurement.

This measurement will give you the pinion shaft or input yoke angle (B).

(6) Subtract smaller figure from larger (C minus B) to obtain axle Input Operating Angle.

Refer to rules given below and the example in (Fig. 12) for additional information.

- Good cancellation of U-joint operating angles (within 1°).
- Operating angles less than 3°.
- At least 1/2 of one degree continuous operating (propeller shaft) angle.

REMOVAL AND INSTALLATION

FRONT PROPELLER SHAFT

NOTE: Different length propeller shafts are used for different drivetrain applications. Ensure that the correct propeller shaft is used.

REMOVAL

- (1) Raise and support vehicle on safety stands.

REMOVAL AND INSTALLATION (Continued)

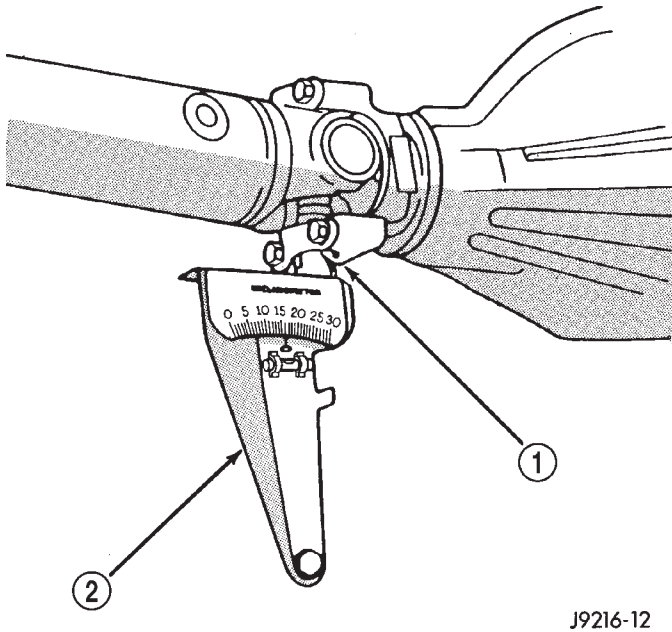

J9216-12

Fig. 11 Rear (Input) Angle Measurement (B)

- 1 - PINION YOKE BEARING CAP
- 2 - SPECIAL TOOL 7663 (J-23498A)

- (2) Shift the transmission and transfer case, if necessary, into the Neutral position.
- (3) Using a suitable marker, mark a line across the companion flange at the transfer case and CV joint at the rear of the front propeller shaft for installation reference.
- (4) Mark a line across the CV joint and the pinion companion flange for installation reference.
- (5) Remove the bolts holding the front CV joint to the pinion companion flange.
- (6) Remove the bolts holding the rear CV joint to the transfer case companion flange.
- (7) Separate the rear CV joint from the transfer case companion flange.
- (8) Push rear of propeller shaft upward to clear transfer case companion flange.
- (9) Separate front CV joint from front axle.
- (10) Separate propeller shaft from vehicle.

INSTALLATION

- (1) Position front propeller shaft under vehicle with rear CV joint over the transfer case companion flange.

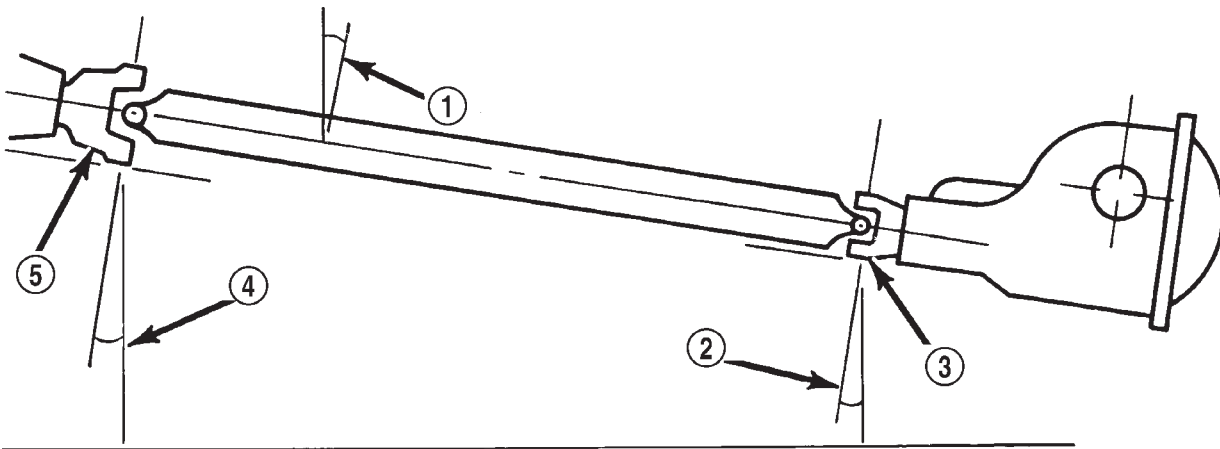

Horizontal Level

- (A) Output Yoke = 3.0° or 4.9°
- (C) Prop. Shaft = 4.9° or -3.0°

- (B) Axle Input Yoke = 3.2° or 4.9°
- (C) Prop. Shaft = 4.9° or -3.2°

Transmission Output Operating Angle 1.9°

Axle Input Operating Angle 1.7°

Trans. Output Operating Angle 1.9°
 Axle Input Operating Angle -1.7°

Amount of U-Joint Cancellation 0.2°

J9316-3

Fig. 12 Universal Joint Angle Example

- 1 - 4.9° Angle (C)
- 2 - 3.2° Angle (B)
- 3 - Input Yoke
- 4 - 3.0° Angle (A)
- 5 - Output Yoke

REMOVAL AND INSTALLATION (Continued)

(2) Place front CV joint into the axle pinion companion flange. CV joint should rotate freely in the pinion flange.

(3) Align mark on the transfer case companion flange to the mark on the CV joint at the rear of the front propeller.

(4) Loosely install bolts to hold CV joint to transfer case companion flange.

(5) Align mark on front CV joint to the mark on the axle pinion companion flange.

(6) Install bolts to hold front CV joint to the axle pinion companion flange. Tighten bolts to 32 N·m (23.5 ft. lbs.).

(7) Tighten bolts to hold rear CV joint to the transfer case companion flange to 32 N·m (23.5 ft. lbs.).

(8) Lower vehicle and road test to verify repair.

REAR PROPELLER SHAFT

REMOVAL

(1) Raise and support vehicle on safety stands.

(2) Shift the transmission and transfer case, if necessary, to their Neutral positions.

(3) Using a suitable marker, mark a line across the axle pinion yoke and the propeller shaft yoke for installation reference.

(4) Remove the bolts holding the universal joint clamps to the pinion yoke.

(5) Slide the slip yoke off of the transmission, or transfer case, output shaft and remove the propeller shaft (Fig. 13).

INSTALLATION

(1) Slide the slip yoke on the transmission, or transfer case, output shaft.

(2) Align the installation reference marks made on the propeller shaft and pinion yoke.

(3) Position universal joint into pinion yoke.

(4) Install the universal joint clamp and clamp bolts to the pinion yoke. Tighten bolts to 19 N·m (14 ft. lbs.).

(5) Lower the vehicle.

DISASSEMBLY AND ASSEMBLY

SINGLE CARDAN UNIVERSAL JOINT

DISASSEMBLY

Individual components of cardan universal joints are not serviceable. If worn or leaking, they must be replaced as an assembly.

(1) Remove the propeller shaft.

(2) Using a soft drift, tap the outside of the bearing cap assembly to loosen snap ring.

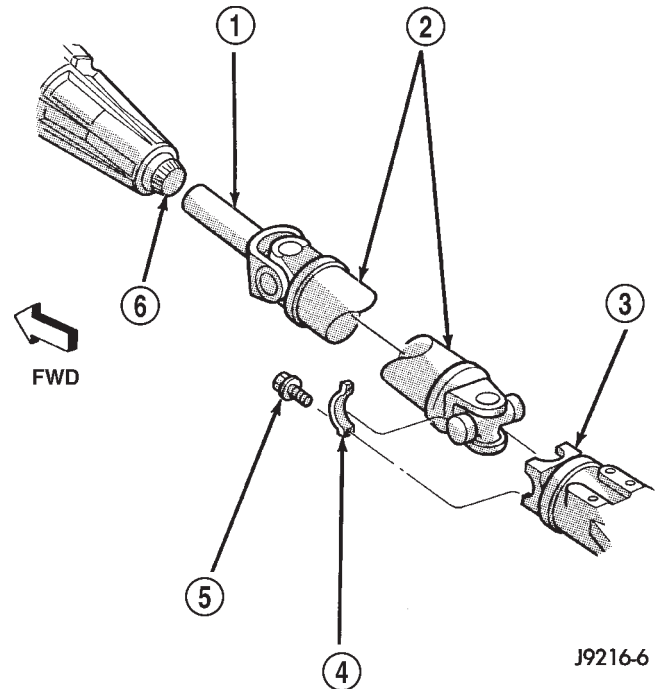

Fig. 13 Rear Propeller Shaft

- 1 - SLIDING YOKE
- 2 - PROPELLER SHAFT
- 3 - PINION YOKE
- 4 - CLAMP
- 5 - SCREW 19 N·m (14 ft-lbs)
- 6 - OUTPUT SHAFT

(3) Remove snap rings from both sides of yoke (Fig. 14).

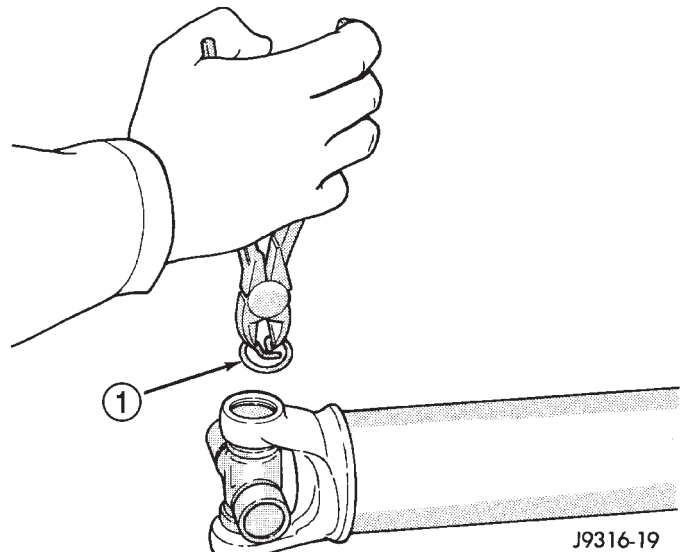

Fig. 14 Remove Snap Ring

- 1 - SNAP RING

DISASSEMBLY AND ASSEMBLY (Continued)

(4) Set the yoke in an arbor press or vise with a socket whose inside diameter is large enough to receive the bearing cap positioned beneath the yoke.

(5) Position the yoke with the grease fitting, if equipped, pointing up.

(6) Place a socket with an outside diameter smaller than the upper bearing cap on the upper bearing cap and press the cap through the yoke to release the lower bearing cap (Fig. 15).

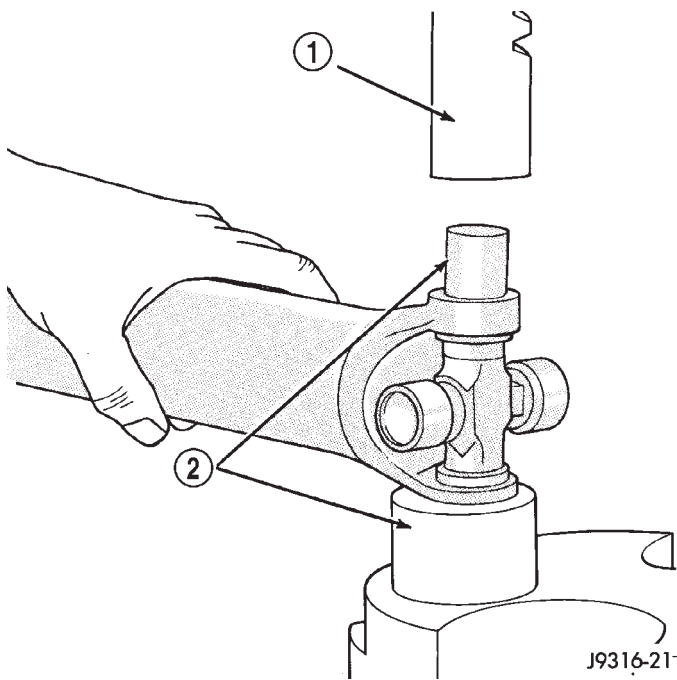

Fig. 15 Press Out Bearing

- 1 - PRESS
- 2 - SOCKET

(7) If the bearing cap will not pull out of the yoke by hand after pressing, tap the yoke ear near the bearing cap to dislodge the cap.

(8) To remove the opposite bearing cap, turn the yoke over and straighten the cross in the open hole. Then, carefully press the end of the cross until the remaining bearing cap can be removed (Fig. 16).

CAUTION: If the cross or bearing cap are not straight during installation, the bearing cap will score the walls of the yoke bore and damage can occur.

ASSEMBLY

(1) Apply extreme pressure (EP) N.L.G.I. Grade 1 or 2 grease to inside of yoke bores to aid in installation.

(2) Position the cross in the yoke with its lube fitting, if equipped, pointing up (Fig. 17).

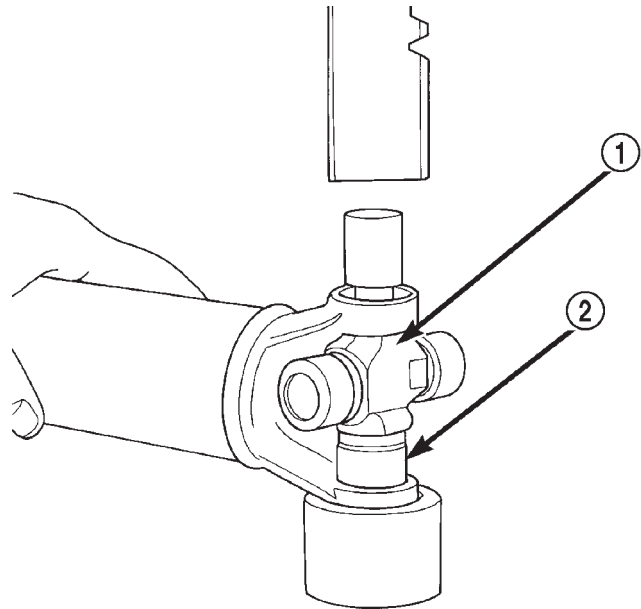

Fig. 16 Press Out Remaining Bearing

- 1 - CROSS
- 2 - BEARING CAP

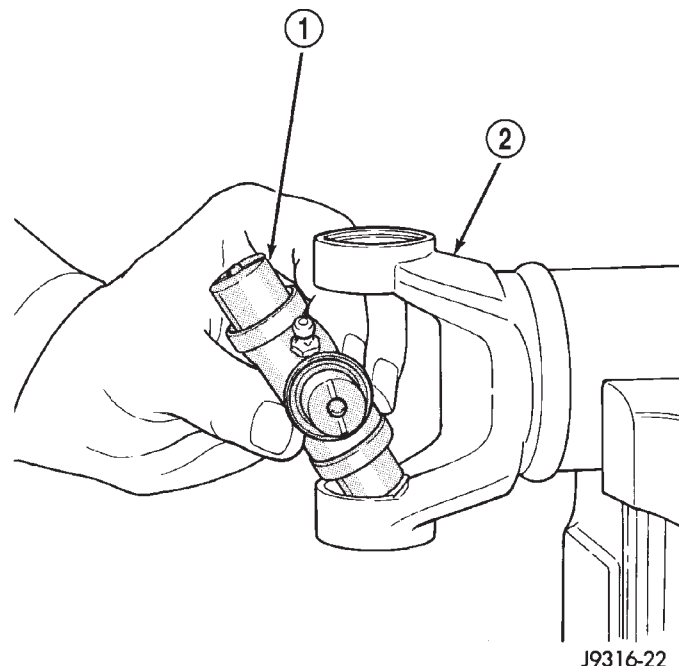

Fig. 17 Install Cross In Yoke

- 1 - CROSS
- 2 - YOKE

(3) Place a bearing cap over the trunnion and align the cap with the yoke bore (Fig. 18). Keep the needle bearings upright in the bearing assembly. A

DISASSEMBLY AND ASSEMBLY (Continued)

needle bearing lying at the bottom of the cap will prevent proper assembly.

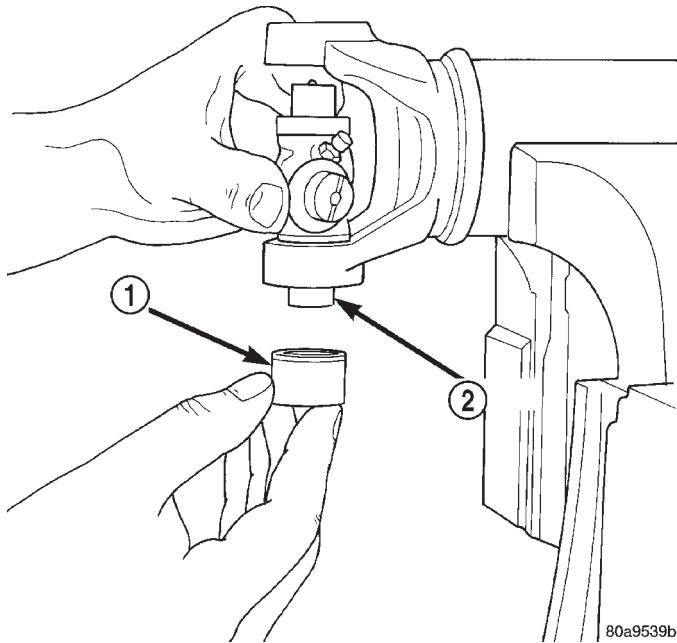

Fig. 18 Install Bearing On Trunnion

- 1 - BEARING CAP
- 2 - TRUNNION

(4) Press the bearing cap into the yoke bore enough to install a snap ring.

(5) Install a snap ring.

(6) Repeat Step 3 and Step 4 to install the opposite bearing cap. If the joint is stiff or binding, strike the yoke with a soft hammer to seat the needle bearings.

(7) Add grease to lube fitting, if equipped.

(8) Install the propeller shaft.

CLEANING AND INSPECTION

SINGLE CARDAN JOINT

(1) Clean all the universal joint yoke bores with cleaning solvent and a wire brush.

(2) Inspect the yokes for distortion, cracks, and worn bearing cap bores.

ADJUSTMENTS

FRONT PROPELLER SHAFT MEASUREMENT

This measurement is to be taken with the shaft installed and the vehicle at proper ride height.

(1) Place vehicle on floor or drive-on hoist with full weight of vehicle on suspension.

(2) Measure the distance from the face of the CV joint cup to the end of the CV joint boot (Fig. 19).

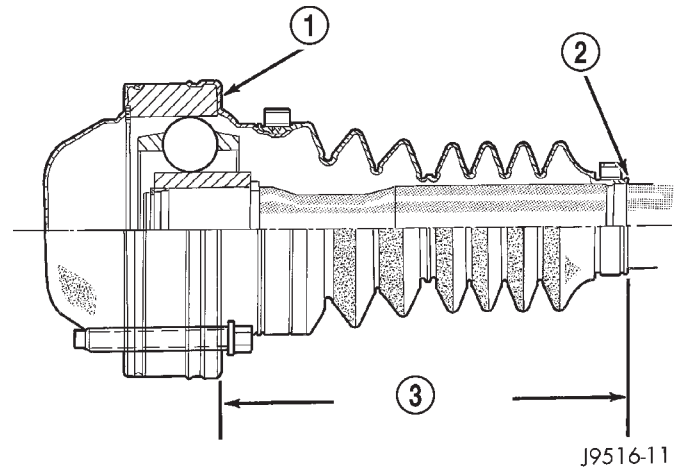

Fig. 19 Measurement

- 1 - CV JOINT CUP
- 2 - CV BOOT END
- 3 - MEASUREMENT

(3) The correct length is 142.7 mm (5.61 in.).

(4) If the measurement is not correct, the wrong shaft may have been installed or a mating component (front axle or transfer case) may be installed incorrectly. Investigate and correct as necessary.

SPECIFICATIONS

TORQUE

FRONT PROPELLER SHAFT

DESCRIPTION	TORQUE
Bolts, Transfer Case	
Companion Flange	32 N·m (23.5 ft. lbs.)
Bolts, Pinion Companion Flange	32 N·m (23.5 ft. lbs.)

REAR PROPELLER SHAFT

DESCRIPTION	TORQUE
Bolts, Rear Yoke	19 N·m (14 ft. lbs.)

SPECIAL TOOLS

PROPELLER SHAFT

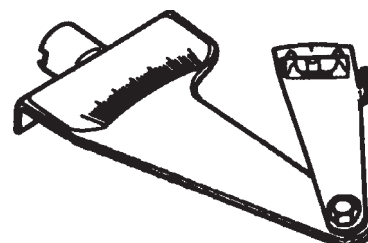

Inclinometer—7663

TUBE AND 186 FBI AXLE

TABLE OF CONTENTS

	page		page
DESCRIPTION AND OPERATION		STEERING KNUCKLE AND BALL STUDS	27
186 FBI AXLE	11	AXLE BUSHING REPLACEMENT	29
LUBRICANT	12	DIFFERENTIAL	29
STANDARD DIFFERENTIAL	12	DIFFERENTIAL SIDE BEARINGS	32
VARI-LOK™ DIFFERENTIAL	13	VARI-LOK™ PLENUM	32
DIAGNOSIS AND TESTING		AXLE SHAFT OIL SEAL	33
GENERAL INFORMATION	13	PINION GEAR	34
GEAR NOISE	16	RING GEAR	38
BEARING NOISE	16	DISASSEMBLY AND ASSEMBLY	
LOW SPEED KNOCK	16	STANDARD DIFFERENTIAL	38
VIBRATION	16	FINAL ASSEMBLY	39
DRIVELINE SNAP	17	CLEANING AND INSPECTION	
VARI-LOK™ TEST	17	CARDAN U-JOINT	40
SERVICE PROCEDURES		AXLE COMPONENTS	40
LUBRICANT CHANGE	17	ADJUSTMENTS	
REMOVAL AND INSTALLATION		PINION GEAR DEPTH	40
DRIVE AXLE ASSEMBLY	18	DIFFERENTIAL BEARING PRELOAD AND	
TUBE AXLE ASSEMBLY	19	GEAR BACKLASH	42
AXLE SHAFT—CARDAN U-JOINT	19	GEAR CONTACT PATTERN ANALYSIS	47
AXLE CONSTANT-VELOCITY (C/V) JOINT		SPECIFICATIONS	
BOOT	20	186 FBI AXLE	49
PINION SHAFT SEAL	21	186 FBI AXLE	49
COLLAPSIBLE SPACER	23	SPECIAL TOOLS	
HUB BEARING AND AXLE SHAFT	25	186 FBI AXLE	49

DESCRIPTION AND OPERATION

186 FBI AXLE

DESCRIPTION

The 186 Front Beam-design Iron (FBI) axle consists of a cast iron differential housing with axle shaft tubes extending from either side. The tubes are pressed into the differential housing and welded.

The integral type housing, hypoid gear design has the centerline of the pinion set below the centerline of the ring gear.

The axle has a fitting for a vent hose used to relieve internal pressure caused by lubricant vaporization and internal expansion.

The axles are equipped with semi-floating axle shafts, meaning that loads are supported by the hub bearings. The axle shafts are retained by nuts at the hub bearings. The hub bearings are bolted to the steering knuckle at the outboard end of the axle tube yoke. The hub bearings are serviced as an assembly.

For vehicles with ABS brakes, the ABS wheel speed sensors are attached to the knuckle assem-

blies. The tone rings for the ABS system are pressed onto the axle shaft. **Do not damage ABS tone wheel or the sensor when removing axle shafts.**

The stamped steel cover provides a means for inspection and servicing the differential.

The 186 FBI axle has the assembly part number and gear ratio listed on a tag. The tag is attached to the housing cover by a cover bolt. Build date identification codes are stamped on the cover side of the axle shaft tube.

The differential case is a one-piece design. The differential pinion mate shaft is retained with a roll pin. Differential bearing preload and ring gear backlash is adjusted by the use of shims (select thickness). The shims are located between the differential bearing cups and axle housing. Pinion bearing preload is set and maintained by the use of a collapsible spacer.

Axles equipped with a Vari-Lok™ differential are optional. A Vari-Lok™ differential has a one-piece differential case which contains the gerotor pump assembly and the clutch mechanism. The Vari-Lok™ unit is serviced only as an assembly.

DESCRIPTION AND OPERATION (Continued)

OPERATION

The axle receives power from the transfer case through the front propeller shaft. The front propeller shaft is connected to the pinion gear which rotates the differential through the gear mesh with the ring gear bolted to the differential case. The engine power is transmitted to the axle shafts through the pinion mate and side gears. The side gears are splined to the axle shafts.

LUBRICANT

DESCRIPTION

A multi-purpose, hypoid gear lubricant which conforms to the following specifications should be used. Mopar® Hypoid Gear Lubricant conforms to all of these specifications.

- The lubricant should have MIL-L-2105C and API GL 5 quality specifications.
- Lubricant is SAE 75W-140 SYNTHETIC gear lubricant.

The 186 FBI, with a standard differential, axle lubricant capacity is 1.18 L (2.5 pts.). The 186 FBI, with a Vari-lok™ differential, axle lubricant capacity is 1.19 L (2.51 pts.), which includes friction modifier. Vari-lok™ equipped vehicles require the addition of 0.07L (0.15 pts.) of friction modifier.

CAUTION: If axle is submerged in water, lubricant must be replaced immediately to avoid possible premature axle failure.

STANDARD DIFFERENTIAL

DESCRIPTION

The differential gear system divides the torque between the axle shafts. It allows the axle shafts to rotate at different speeds when turning corners.

Each differential side gear is splined to an axle shaft. The pinion gears are mounted on a pinion mate shaft and are free to rotate on the shaft. The pinion gear is fitted in a bore in the differential case and is positioned at a right angle to the axle shafts.

OPERATION

In operation, power flow occurs as follows:

- The pinion gear rotates the ring gear
- The ring gear (bolted to the differential case) rotates the case
- The differential pinion gears (mounted on the pinion mate shaft in the case) rotate the side gears
- The side gears (splined to the axle shafts) rotate the shafts

During straight-ahead driving, the differential pinion gears do not rotate on the pinion mate shaft. This

occurs because input torque applied to the gears is divided and distributed equally between the two side gears. As a result, the pinion gears revolve with the pinion mate shaft but do not rotate around it (Fig. 1).

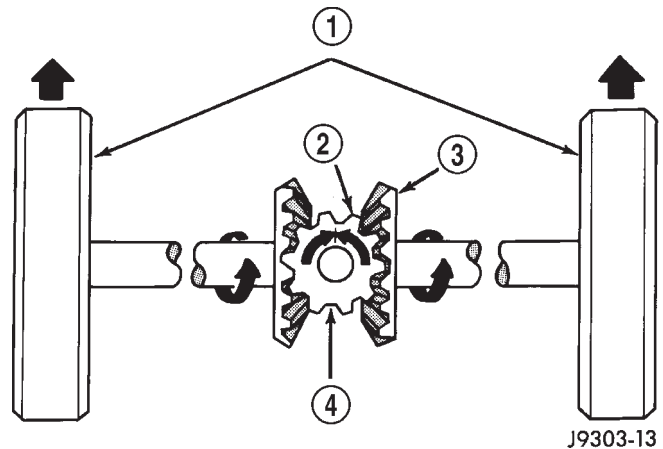

J9303-13

Fig. 1 Differential Operation—Straight Ahead Driving

- 1 - IN STRAIGHT AHEAD DRIVING EACH WHEEL ROTATES AT 100% OF CASE SPEED
- 2 - PINION GEAR
- 3 - SIDE GEAR
- 4 - PINION GEARS ROTATE WITH CASE

When turning corners, the outside wheel must travel a greater distance than the inside wheel to complete a turn. The difference must be compensated for to prevent the tires from scuffing and skidding through turns. To accomplish this, the differential allows the axle shafts to turn at unequal speeds (Fig. 2). In this instance, the input torque applied to the pinion gears is not divided equally. The pinion gears now rotate around the pinion mate shaft in opposite directions. This allows the side gear and axle shaft attached to the outside wheel to rotate at a faster speed.

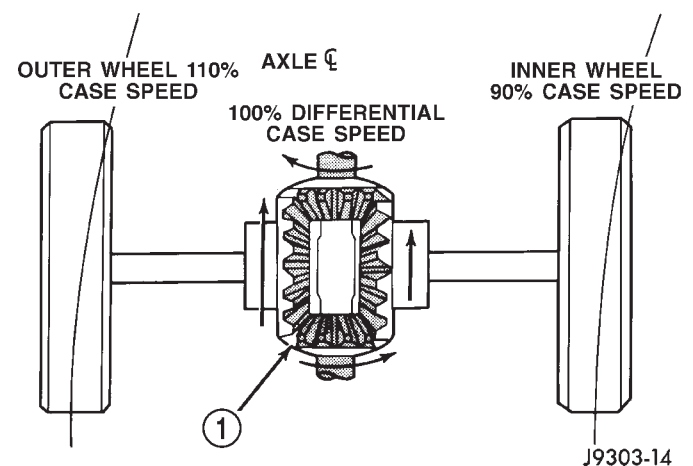

J9303-14

Fig. 2 Differential Operation—On Turns

- 1 - PINION GEARS ROTATE ON PINION SHAFT

DESCRIPTION AND OPERATION (Continued)

VARI-LOK™ DIFFERENTIAL**DESCRIPTION**

Vari-lok™ differentials are a speed-sensing torque transfer differential. Similar to Trac-lok™ differentials, these differentials transfer torque to the wheel with the greater traction. Unlike typical differential systems, torque transfer is proportional to wheel speed difference rather than torque difference. Response can be tuned to driving conditions, enabling use of this system in the front axle. Both front and rear Vari-lok™ axle torque transfer characteristics are tuned to provide smooth operation. Except for the ability to maintain headway under low-traction conditions, operation is barely noticeable to the driver.

OPERATION

In a standard differential, if one wheel spins, the opposite wheel will generate only as much torque as the spinning wheel.

A gerotor pump and clutch pack are used to provide the torque transfer capability. One axle shaft is splined to the gerotor pump and one of the differential side gears, which provides the input to the pump. As a wheel begins to lose traction, the speed differential is transmitted from one side of the differential to the other through the side gears. The motion of one side gear relative to the other turns the inner rotor of the pump. Since the outer rotor of the pump is grounded to the differential case, the inner and outer rotors are now moving relative to each other and therefore creates pressure in the pump. The tuning of the front and rear axle orifices and valves inside the gerotor pump is unique and each system includes a torque-limiting pressure relief valve to protect the clutch pack, which also facilitates vehicle control under extreme side-to-side traction variations. The resulting pressure is applied to the clutch pack and the transfer of torque is completed.

Under conditions in which opposite wheels are on surfaces with widely different friction characteristics, Vari-lok™ delivers far more torque to the wheel on

the higher traction surface than do conventional Trac-lok™ systems. Because conventional Trac-lok™ differentials are initially pre-loaded to assure torque transfer, normal driving (where inner and outer wheel speeds differ during cornering, etc.) produces torque transfer during even slight side-to-side speed variations. Since these devices rely on friction from this preload to transfer torque, normal use tends to cause wear that reduces the ability of the differential to transfer torque over time. By design, the Vari-lok™ system is less subject to wear, remaining more consistent over time in its ability to transfer torque. The coupling assembly is serviced as a unit. From a service standpoint the coupling also benefits from using the same lubricant supply as the ring and pinion gears.

DIAGNOSIS AND TESTING**GENERAL INFORMATION**

Axle bearing problem conditions are usually caused by:

- Insufficient or incorrect lubricant.
- Foreign matter/water contamination.
- Incorrect bearing preload torque adjustment.
- Incorrect backlash.

Axle gear problem conditions are usually the result of:

- Insufficient lubrication.
- Incorrect or contaminated lubricant.
- Overloading (excessive engine torque) or exceeding vehicle weight capacity.

- Incorrect clearance or backlash adjustment.

Axle component breakage is most often the result of:

- Severe overloading.
- Insufficient lubricant.
- Incorrect lubricant.
- Improperly tightened components.
- Differential housing bores not square to each other.

DIAGNOSIS AND TESTING (Continued)

DIAGNOSTIC CHART

Condition	Possible Causes	Correction
Wheel Noise	<ol style="list-style-type: none"> 1. Wheel loose. 2. Faulty, brinelled wheel bearing. 	<ol style="list-style-type: none"> 1. Tighten loose nuts. 2. Replace bearing.
Axle Shaft Noise	<ol style="list-style-type: none"> 1. Misaligned axle tube. 2. Bent or sprung axle shaft. 3. End-play in pinion bearings. 4. Excessive gear backlash between the ring gear and pinion. 5. Improper adjustment of pinion gear bearings. 6. Loose pinion yoke nut. 7. Scuffed gear tooth contact surfaces. 	<ol style="list-style-type: none"> 1. Inspect axle tube alignment. Correct as necessary. 2. Inspect and correct as necessary. 3. Refer to pinion pre-load information and correct as necessary. 4. Check adjustment of the ring gear and pinion backlash. Correct as necessary. 5. Adjust the pinion bearings pre-load. 6. Tighten the pinion yoke nut. 7. Inspect and replace as necessary.
Axle Shaft Broke	<ol style="list-style-type: none"> 1. Misaligned axle tube. 2. Vehicle overloaded. 3. Erratic clutch operation. 4. Grabbing clutch. 	<ol style="list-style-type: none"> 1. Replace the broken shaft after correcting tube mis-alignment. 2. Replace broken shaft and avoid excessive weight on vehicle. 3. Replace broken shaft and avoid or correct erratic clutch operation. 4. Replace broken shaft and inspect and repair clutch as necessary.
Differential Cracked	<ol style="list-style-type: none"> 1. Improper adjustment of the differential bearings. 2. Excessive ring gear backlash. 3. Vehicle overloaded. 4. Erratic clutch operation. 	<ol style="list-style-type: none"> 1. Replace case and inspect gears and bearings for further damage. Set differential bearing pre-load properly. 2. Replace case and inspect gears and bearings for further damage. Set ring gear backlash properly. 3. Replace case and inspect gears and bearings for further damage. Avoid excessive vehicle weight. 4. Replace case and inspect gears and bearings for further damage. Avoid erratic use of clutch.

DIAGNOSIS AND TESTING (Continued)

Condition	Possible Causes	Correction
Differential Gears Scored	<ol style="list-style-type: none"> 1. Insufficient lubrication. 2. Improper grade of lubricant. 3. Excessive spinning of one wheel/tire. 	<ol style="list-style-type: none"> 1. Replace scored gears. Fill differential with the correct fluid type and quantity. 2. Replace scored gears. Fill differential with the correct fluid type and quantity. 3. Replace scored gears. Inspect all gears, pinion bores, and shaft for damage. Service as necessary.
Loss Of Lubricant	<ol style="list-style-type: none"> 1. Lubricant level too high. 2. Worn axle shaft seals. 3. Cracked differential housing. 4. Worn pinion seal. 5. Worn/scored yoke. 6. Axle cover not properly sealed. 	<ol style="list-style-type: none"> 1. Drain lubricant to the correct level. 2. Replace seals. 3. Repair as necessary. 4. Replace seal. 5. Replace yoke and seal. 6. Remove, clean, and re-seal cover.
Axle Overheating	<ol style="list-style-type: none"> 1. Lubricant level low. 2. Improper grade of lubricant. 3. Bearing pre-loads too high. 4. Insufficient ring gear backlash. 	<ol style="list-style-type: none"> 1. Fill differential to correct level. 2. Fill differential with the correct fluid type and quantity. 3. Re-adjust bearing pre-loads. 4. Re-adjust ring gear backlash.
Gear Teeth Broke	<ol style="list-style-type: none"> 1. Overloading. 2. Erratic clutch operation. 3. Ice-spotted pavement. 4. Improper adjustments. 	<ol style="list-style-type: none"> 1. Replace gears. Examine other gears and bearings for possible damage. 2. Replace gears and examine the remaining parts for damage. Avoid erratic clutch operation. 3. Replace gears and examine remaining parts for damage. 4. Replace gears and examine remaining parts for damage. Ensure ring gear backlash is correct.

DIAGNOSIS AND TESTING (Continued)

Condition	Possible Causes	Correction
Axle Noise	<ol style="list-style-type: none"> 1. Insufficient lubricant. 2. Improper ring gear and pinion adjustment. 3. Unmatched ring gear and pinion. 4. Worn teeth on ring gear and/or pinion. 5. Loose pinion bearings. 6. Loose differential bearings. 7. Mis-aligned or sprung ring gear. 8. Loose differential bearing cap bolts. 9. Housing not machined properly. 	<ol style="list-style-type: none"> 1. Fill differential with the correct fluid type and quantity. 2. Check ring gear and pinion contact pattern. 3. Replace gears with a matched ring gear and pinion. 4. Replace ring gear and pinion. 5. Adjust pinion bearing pre-load. 6. Adjust differential bearing pre-load. 7. Measure ring gear run-out. Replace components as necessary. 8. Inspect differential components and replace as necessary. Ensure that the bearing caps are torqued to the proper specification. 9. Replace housing.

GEAR NOISE

Axle gear noise can be caused by insufficient lubricant, incorrect backlash, tooth contact, worn/damaged gears, or the carrier housing not having the proper offset and squareness.

Gear noise usually happens at a specific speed range. The noise can also occur during a specific type of driving condition. These conditions are acceleration, deceleration, coast, or constant load.

When road testing, first warm-up the axle fluid by driving the vehicle at least 5 miles and then accelerate the vehicle to the speed range where the noise is the greatest. Shift out-of-gear and coast through the peak-noise range. If the noise stops or changes greatly:

- Check for insufficient lubricant.
- Incorrect ring gear backlash.
- Gear damage.

Differential side gears and pinions can be checked by turning the vehicle. They usually do not cause noise during straight-ahead driving when the gears are unloaded. The side gears are loaded during vehicle turns. A worn pinion mate shaft can also cause a snapping or a knocking noise.

BEARING NOISE

The axle shaft, differential and pinion bearings can all produce noise when worn or damaged. Bearing noise can be either a whining, or a growling sound.

Pinion bearings have a constant-pitch noise. This noise changes only with vehicle speed. Pinion bearing noise will be higher pitched because it rotates at a

faster rate. Drive the vehicle and load the differential. If bearing noise occurs, the rear pinion bearing is the source of the noise. If the bearing noise is heard during a coast, the front pinion bearing is the source.

Worn or damaged differential bearings usually produce a low pitch noise. Differential bearing noise is similar to pinion bearing noise. The pitch of differential bearing noise is also constant and varies only with vehicle speed.

Axle shaft bearings produce noise and vibration when worn or damaged. The noise generally changes when the bearings are loaded. Road test the vehicle. Turn the vehicle sharply to the left and to the right. This will load the bearings and change the noise level. Where axle bearing damage is slight, the noise is usually not noticeable at speeds above 30 mph.

LOW SPEED KNOCK

Low speed knock is generally caused by a worn U-joint or by worn side-gear thrust washers. A worn pinion shaft bore will also cause low speed knock.

VIBRATION

Vibration at the rear of the vehicle is usually caused by a:

- Damaged drive shaft.
- Missing drive shaft balance weight(s).
- Worn or out-of-balance wheels.
- Loose wheel lug nuts.
- Worn U-joint(s).
- Loose/broken springs.

DIAGNOSIS AND TESTING (Continued)

- Damaged axle shaft bearing(s).
- Loose pinion gear nut.
- Excessive pinion yoke run out.
- Bent axle shaft(s).

Check for loose or damaged front-end components or engine/transmission mounts. These components can contribute to what appears to be a rear-end vibration. Do not overlook engine accessories, brackets and drive belts.

All driveline components should be examined before starting any repair.

Refer to Group 22, Wheels and Tires, for additional vibration information.

DRIVELINE SNAP

A snap or clunk noise when the vehicle is shifted into gear (or the clutch engaged), can be caused by:

- High engine idle speed.
- Transmission shift operation.
- Loose engine/transmission/transfer case mounts.
- Worn U-joints.
- Loose spring mounts.
- Loose pinion gear nut and yoke.
- Excessive ring gear backlash.
- Excessive side gear to case clearance.

The source of a snap or a clunk noise can be determined with the assistance of a helper. Raise the vehicle on a hoist with the wheels free to rotate. Instruct the helper to shift the transmission into gear. Listen for the noise, a mechanics stethoscope is helpful in isolating the source of a noise.

VARI-LOK™ TEST

PRIMING

- (1) Park the vehicle on a level surface or raise vehicle on hoist so that the vehicle is level.
- (2) Remove the axle fill plug.
- (3) Verify that the axle fluid level is correct. The fluid level is correct if the fluid is level with the bottom of the fill hole.
- (4) Shift the transfer case into the 4WD full-time position.
- (5) Drive the vehicle in a tight circle for 2 minutes at 5mph to fully prime the pump.

TEST PROCEDURE

- (1) Block the tires opposite the axle to be tested to prevent the vehicle from moving.
- (2) Shift the transfer case into the 4WD Low position and the transmission into the Park position.
- (3) Raise both the wheels of the axle to be tested off of the ground.
- (4) Rotate the left wheel by hand at a minimum of one revolution per second while an assistant rotates the right wheel in the opposite direction.

(5) The left wheel should spin freely at first and then increase in resistance within 5 revolutions until the wheels cannot be continuously rotated in opposite directions.

(6) The Vari-lok™ differential has engaged properly if the wheels cannot be rotated in opposite directions for a moment. After the wheels stop rotating for a moment, the fluid pressure will drop in the differential and the wheels begin to rotate once again.

(7) If the system does not operate properly, replace the Vari-lok™ differential.

SERVICE PROCEDURES

LUBRICANT CHANGE

- (1) Raise and support the vehicle.
- (2) Remove the lubricant fill hole plug from the differential housing cover.
- (3) Remove the differential housing cover and drain the lubricant from the housing.
- (4) Clean the housing cavity with a flushing oil, light engine oil or lint free cloth. **Do not use water, steam, kerosene or gasoline for cleaning.**
- (5) Remove the sealant from the housing and cover surfaces. Use solvent to clean the mating surfaces.
- (6) Apply a bead of Mopar® Silicone Rubber Sealant, or equivalent, to the housing cover (Fig. 3).

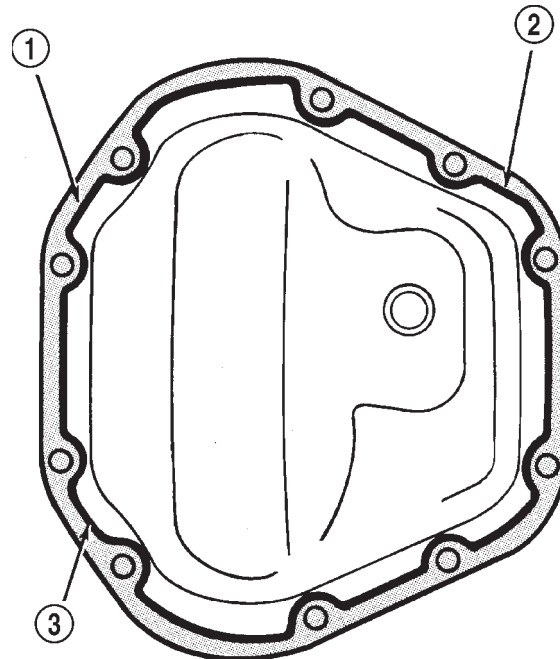

J9302-30

Fig. 3 Typical Housing Cover With Sealant

- 1 - SEALING SURFACE
- 2 - CONTOUR OF BEAD
- 3 - BEAD THICKNESS 6.35mm (1/4")

SERVICE PROCEDURES (Continued)

Install the housing cover within 5 minutes after applying the sealant.

(7) Install the cover and any identification tag. Tighten the cover bolts in a criss-cross pattern to 41 N·m (30 ft. lbs.) torque.

(8) For Vari-lok[™] differentials, a quantity of Mopar[®] Trac-lok[™] lubricant (friction modifier), or equivalent, must be added after repair service or a lubricant change. Refer to the Lubricant Specifications section of this group for the quantity necessary.

(9) Refill the differential with the correct lubricant to bottom of the fill plug hole. Refer to the Lubricant Specifications in this group for the quantity necessary.

(10) Install the fill hole plug and lower the vehicle. Tighten fill plug to 34 N·m (25 ft. lbs.).

(11) Vari-lok[™] differential equipped vehicles should be road tested by making 10 to 12 slow figure-eight turns. This maneuver will pump the lubricant through the clutch discs to eliminate a possible chatter noise complaint.

REMOVAL AND INSTALLATION

DRIVE AXLE ASSEMBLY

REMOVAL

- (1) Raise and support the vehicle.
- (2) Position a suitable lifting device under the axle.
- (3) Secure axle to device.
- (4) Remove the wheels and tires.
- (5) Remove the brake rotors and calipers from the axle. Refer to Group 5, Brakes, for proper procedures.
- (6) Disconnect the wheel sensor wiring harness from the vehicle wiring harness, if necessary.
- (7) Disconnect the vent hose from the axle shaft tube.
- (8) Mark the propeller shaft and yoke, or pinion flange, for installation alignment reference.
- (9) Remove propeller shaft.
- (10) Disconnect stabilizer bar links at the axle.
- (11) Disconnect shock absorbers from axle brackets.
- (12) Disconnect track bar.
- (13) Disconnect the tie rod and drag link from the steering knuckle. Refer to Group 2, Suspension, for proper procedures.
- (14) Disconnect the steering damper from the axle bracket.
- (15) Disconnect the upper and lower suspension arms from the axle brackets.
- (16) Lower the lifting device enough to remove the axle. The coil springs will drop with the axle.
- (17) Remove the coil springs from the axle.

INSTALLATION

CAUTION: The weight of the vehicle must be supported by the springs before suspension arms and track bar fasteners can be tightened. If the springs are not at their normal ride position, ride height and handling could be affected.

- (1) Install the springs and retainer clips. Tighten the retainer bolts to 21 N·m (16 ft. lbs.) torque.
- (2) Support the axle on a suitable lifting device and position axle under the vehicle.
- (3) Raise the axle and align it with the spring pads.
- (4) Position the upper and lower suspension arms in the axle brackets. Loosely install bolts and nuts to hold suspension arms to the axle brackets.
- (5) Connect the vent hose to the axle shaft tube.
- (6) Connect the track bar to the axle bracket. Loosely install the bolt to hold the track bar to the axle bracket.
- (7) Install the shock absorbers and tighten the bolts to 23 N·m (17 ft. lbs.) torque.
- (8) Install the stabilizer bar links to the axle brackets. Tighten the nut to 95 N·m (70 ft. lbs.) torque.
- (9) Install the drag link and tie rod to the steering knuckles. Refer to Group 2, Suspension, for proper procedures.
- (10) Install the steering damper to the axle bracket and tighten the nut to 75 N·m (55 ft. lbs.) torque.
- (11) Install the brake rotors and calipers. Refer to Group 5, Brakes, for the proper procedures.
- (12) Connect the wheel speed sensor wiring harness to the vehicle wiring harness, if necessary.
- (13) Align the previously made marks on the propeller shaft and the yoke, or pinion flange.
- (14) Install the bolts to hold the propeller shaft to the pinion flange, if equipped.
- (15) Install the straps and bolts to hold the propeller shaft to the yoke, if equipped.
- (16) Check and fill axle lubricant. Refer to the Lubricant Specifications in this group for the quantity necessary.
- (17) Install the wheel and tire assemblies.
- (18) Remove the lifting device from the axle and lower the vehicle.
- (19) Tighten the upper suspension arm nuts to 75 N·m (55 ft. lbs.) torque. Tighten the lower suspension arm nuts to 115 N·m (85 ft. lbs.) torque.
- (20) Tighten the track bar bolt at the axle bracket to 100 N·m (74 ft. lbs.) torque.
- (21) Check the front wheel alignment.

REMOVAL AND INSTALLATION (Continued)

TUBE AXLE ASSEMBLY

REMOVAL

- (1) Raise and support the vehicle.
- (2) Position a suitable lifting device under the axle.
- (3) Secure axle to device.
- (4) Remove the wheels and tires.
- (5) Remove the brake rotors and calipers from the axle. Refer to Group 5, Brakes, for proper procedures.
- (6) Disconnect the wheel sensor wiring harness from the vehicle wiring harness, if necessary.
- (7) Disconnect stabilizer bar links at the axle.
- (8) Disconnect shock absorbers from axle brackets.
- (9) Disconnect track bar.
- (10) Disconnect the tie rod and drag link from the steering knuckle. Refer to Group 2, Suspension, for proper procedures.
- (11) Disconnect the steering damper from the axle bracket.
- (12) Disconnect the upper and lower suspension arms from the axle brackets.
- (13) Lower the lifting device enough to remove the axle. The coil springs will drop with the axle.
- (14) Remove the coil springs from the axle.

INSTALLATION

CAUTION: The weight of the vehicle must be supported by the springs before suspension arms and track bar fasteners can be tightened. If the springs are not at their normal ride position, ride height and handling could be affected.

- (1) Install the springs and retainer clips. Tighten the retainer bolts to 21 N·m (16 ft. lbs.) torque.
- (2) Support the axle on a suitable lifting device and position axle under the vehicle.
- (3) Raise the axle and align it with the spring pads.
- (4) Position the upper and lower suspension arms in the axle brackets. Loosely install bolts and nuts to hold suspension arms to the axle brackets.
- (5) Connect the track bar to the axle bracket. Loosely install the bolt to hold the track bar to the axle bracket.
- (6) Install the shock absorbers and tighten the bolts to 23 N·m (17 ft. lbs.) torque.
- (7) Install the stabilizer bar links to the axle brackets. Tighten the nut to 95 N·m (70 ft. lbs.) torque.
- (8) Install the drag link and tie rod to the steering knuckles. Refer to Group 2, Suspension, for proper procedures.
- (9) Install the steering damper to the axle bracket and tighten the nut to 75 N·m (55 ft. lbs.) torque.

(10) Install the brake rotors and calipers. Refer to Group 5, Brakes, for the proper procedures.

(11) Connect the wheel speed sensor wiring harness to the vehicle wiring harness, if necessary.

(12) Install the wheel and tire assemblies.

(13) Remove the lifting device from the axle and lower the vehicle.

(14) Tighten the upper suspension arm nuts to 75 N·m (55 ft. lbs.) torque. Tighten the lower suspension arm nuts to 115 N·m (85 ft. lbs.) torque.

(15) Tighten the track bar bolt at the axle bracket to 100 N·m (74 ft. lbs.) torque.

(16) Check the front wheel alignment.

AXLE SHAFT—CARDAN U-JOINT

Single cardan U-joint components are not serviceable. If defective, they must be replaced as a unit. If the bearings, seals, spider, or bearing caps are damaged or worn, replace the complete U-joint.

REMOVAL

CAUTION: Clamp only the narrow forged portion of the yoke in the vise. Also, to avoid distorting the yoke, do not over tighten the vise jaws.

- (1) Remove axle shaft.
- (2) Remove the bearing cap retaining snap rings (Fig. 4).

It can be helpful to saturate the bearing caps with penetrating oil prior to removal.

(3) Locate a socket where the inside diameter is larger in diameter than the bearing cap. Place the socket (receiver) against the yoke and around the perimeter of the bearing cap to be removed.

(4) Locate a socket where the outside diameter is smaller in diameter than the bearing cap. Place the socket (driver) against the opposite bearing cap.

(5) Position the yoke with the sockets in a vise (Fig. 5).

(6) Compress the vise jaws to force the bearing cap into the larger socket (receiver).

(7) Release the vise jaws. Remove the sockets and bearing cap that was partially forced out of the yoke.

(8) Repeat the above procedure for the remaining bearing cap.

(9) Remove the remaining bearing cap, bearings, seals and spider from the propeller shaft yoke.

INSTALLATION

(1) Pack the bearing caps 1/3 full of wheel bearing lubricant. Apply extreme pressure (EP), lithium-base lubricant to aid in installation.

(2) Position the spider in the yoke. Insert the seals and bearings. Tap the bearing caps into the yoke bores far enough to hold the spider in position.

REMOVAL AND INSTALLATION (Continued)

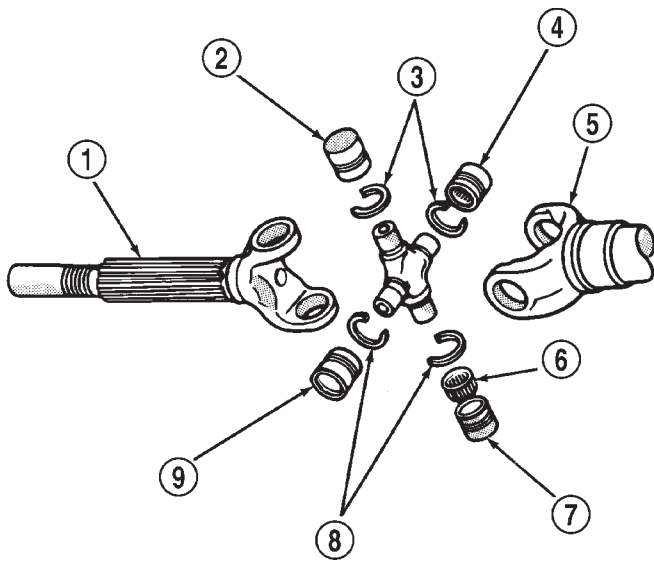

J8902-15

Fig. 4 Axle Shaft Outer U-Joint

- 1 - SHAFT YOKE
- 2 - BEARING CAP
- 3 - SNAP RINGS
- 4 - BEARING CAP
- 5 - SPINDLE YOKE
- 6 - BEARING
- 7 - BEARING CAP
- 8 - SNAP RINGS
- 9 - BEARING CAP

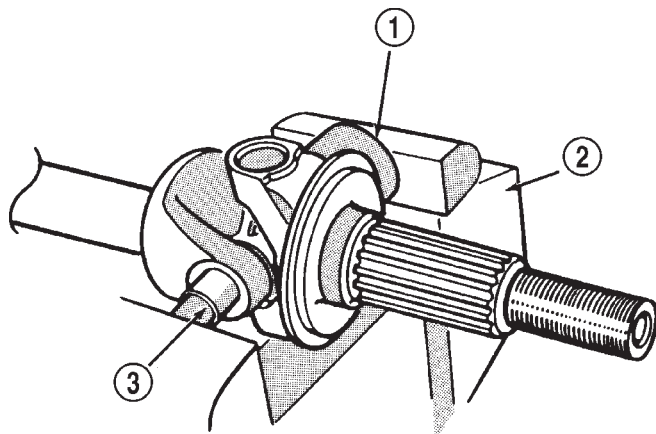

J8902-16

Fig. 5 Yoke Bearing Cap Removal

- 1 - LARGE-DIAMETER SOCKET WRENCH
- 2 - VISE
- 3 - SMALL-DIAMETER SOCKET WRENCH

(3) Place the socket (driver) against one bearing cap. Position the yoke with the socket wrench in a vise.

(4) Compress the vise to force the bearing caps into the yoke. Force the caps enough to install the retaining clips.

(5) Install the bearing cap retaining clips.

(6) Install axle shaft.

AXLE CONSTANT-VELOCITY (C/V) JOINT BOOT

The only service procedure to be performed on the axle C/V joint, is the replacement of the joint seal boot. If any failure of internal axle shaft components is diagnosed during a vehicle road test, the axle shaft must be replaced as an assembly.

REMOVAL

(1) Remove axle shaft.

(2) Remove large boot clamp retaining C/V joint sealing boot, to C/V joint housing and discard.

(3) Remove small clamp that retains outer C/V joint sealing boot to axle shaft and discard (Fig. 6).

(4) Remove sealing boot from outer C/V joint housing and slide it down and off the axle shaft.

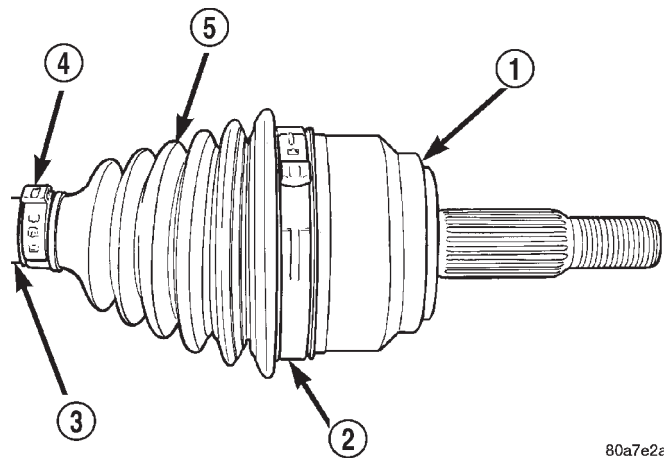

80a7e2ab

Fig. 6 Outer C/V Joint Seal Boot Clamps

- 1 - AXLE C/V JOINT HOUSING
- 2 - LARGE CLAMP
- 3 - AXLE SHAFT
- 4 - SMALL CLAMP
- 5 - SEALING BOOT

(5) Thoroughly clean and inspect axle C/V joint assembly and axle shaft for any signs of excessive wear. **If any parts show signs of excessive wear, the axle shaft assembly will require replacement. Component parts of these axle shaft assemblies are not serviceable.**

INSTALLATION

(1) Slide new sealing boot large clamp over axle shaft and onto C/V joint.

REMOVAL AND INSTALLATION (Continued)

(2) Slide the axle C/V joint sealing boot onto the axle shaft.

(3) Distribute 1/2 the amount of grease provided in seal boot service package (DO NOT USE ANY OTHER TYPE OF GREASE) into axle C/V joint assembly housing. Put the remaining amount into the sealing boot.

(4) Install axle C/V joint boot small clamp evenly on sealing boot.

(5) Position axle C/V joint boot into retaining groove in axle C/V joint housing. Then, install large retaining clamp evenly on sealing boot.

(6) Clamp small sealing boot clamp onto axle shaft using Crimper C-4975-A. Place crimping tool C-4975-A over bridge of clamp (Fig. 7).

(7) Tighten nut on crimping tool C-4975-A until jaws on tool are closed completely together, face to face (Fig. 8).

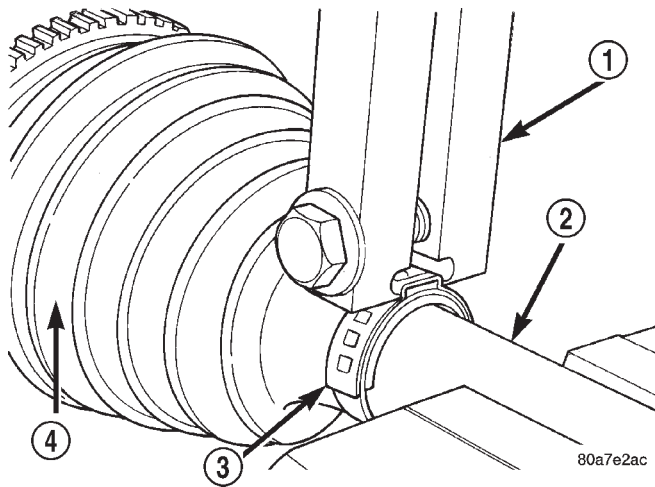

Fig. 7 Crimping Tool Installed On Boot Clamp

- 1 - SPECIAL TOOL C-4975A
- 2 - AXLE SHAFT
- 3 - CLAMP
- 4 - SEALING BOOT

CAUTION: Seal must not be dimpled, stretched or out of shape in any way. If seal is NOT shaped correctly, equalize pressure in seal and shape it by hand.

(8) Clamp large sealing boot clamp onto axle shaft using Crimper C-4975-A. Place crimping tool C-4975-A over bridge of clamp (Fig. 9).

(9) Tighten nut on crimping tool C-4975-A until jaws on tool are closed completely together, face to face.

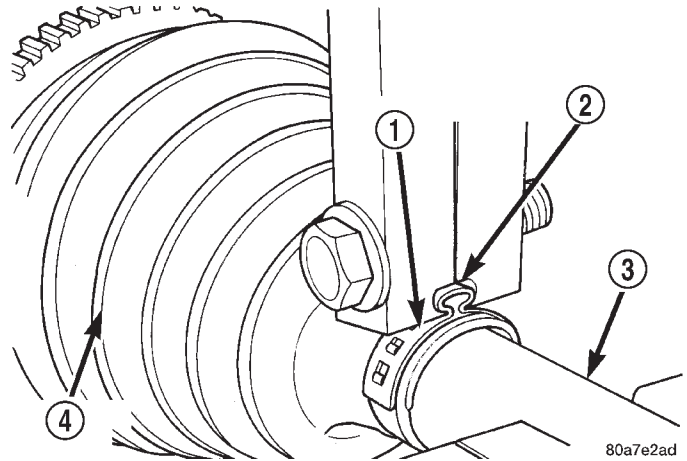

Fig. 8 Sealing Boot Retaining Clamp Installed

- 1 - CLAMP
- 2 - JAWS OF SPECIAL TOOL C-4975A MUST BE CLOSED COMPLETELY TOGETHER HERE
- 3 - AXLE SHAFT
- 4 - SEALING BOOT

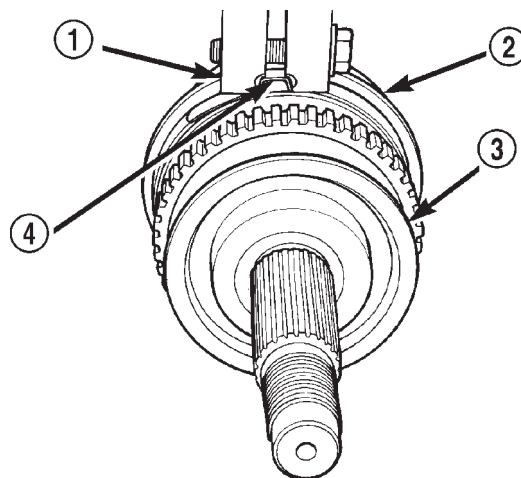

Fig. 9 Crimping Tool Installed On Large Boot Clamp

- 1 - SPECIAL TOOL C-4975A
- 2 - SEALING BOOT
- 3 - OUTER C/V JOINT
- 4 - BOOT CLAMP

PINION SHAFT SEAL

REMOVAL

- (1) Raise and support the vehicle.
- (2) Remove wheel and tire assemblies.
- (3) Remove brake rotors and calipers. Refer to Group 5, Brakes, for proper procedures.
- (4) Mark the propeller shaft and pinion companion flange for installation reference.
- (5) Remove the propeller shaft from the pinion companion flange.

REMOVAL AND INSTALLATION (Continued)

(6) Rotate the pinion gear a minimum of ten times. Verify that the pinion rotates smoothly.

(7) Measure the amount of torque necessary to rotate the pinion gear with a (in. lbs.) dial-type torque wrench. Record the torque reading for installation reference.

(8) Using a short piece of pipe and Holder 6958 to hold the pinion companion flange, remove the pinion nut and washer.

(9) Use Remover C-452 and Wrench C-3281 to remove the pinion companion flange.

(10) Use Remover 7794-A and slide hammer to remove the pinion shaft seal (Fig. 10).

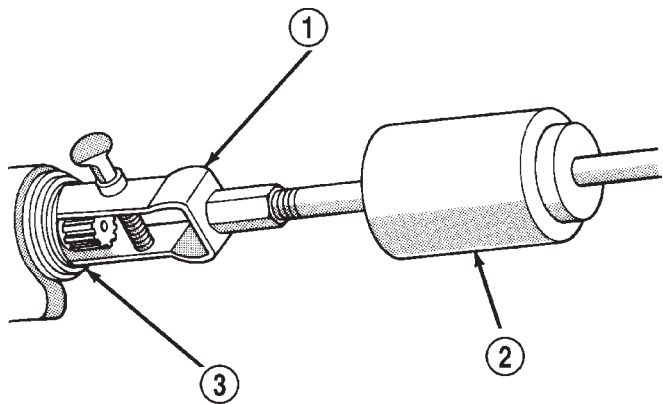

J9402-59X

Fig. 10 Seal Removal

- 1 - SPECIAL TOOL 7794A
- 2 - SLIDE HAMMER
- 3 - PINION SEAL

INSTALLATION

(1) Apply a light coating of gear lubricant on the lip of pinion seal. Install seal with Installer 8108 and Handle C-4171 (Fig. 11).

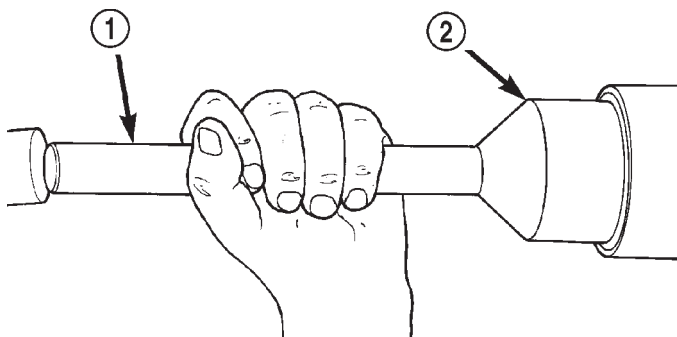

80a98349

Fig. 11 Pinion Seal Installation

- 1 - SPECIAL TOOL C-4171
- 2 - SPECIAL TOOL C-8108

(2) Install pinion companion flange on the pinion gear with Installer W-162-D, Cup 8109, and Holder 6958.

CAUTION: Do not exceed the minimum tightening torque when installing the pinion companion flange retaining nut at this point. Damage to collapsible spacer or bearings may result.

(3) Install the pinion washer and a new nut on the pinion gear. **Tighten the nut only enough to remove the shaft end play.**

(4) Rotate the pinion a minimum of ten times. Verify that the pinion rotates smoothly. Rotate the pinion shaft using a (in. lbs.) torque wrench. Rotating torque should be equal to the reading recorded during removal, plus an additional 0.56 N·m (5 in. lbs.) (Fig. 12).

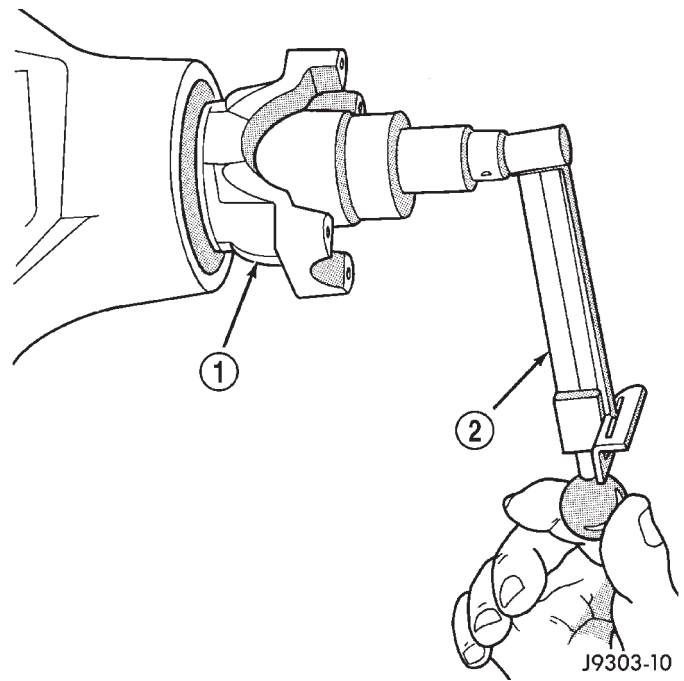

J9303-10

Fig. 12 Check Pinion Rotation Torque—Typical

- 1 - PINION YOKE
- 2 - INCH POUND TORQUE WRENCH

(5) If the rotating torque is low, use Holder 6958 to hold the pinion companion flange (Fig. 13), and tighten the pinion shaft nut in 6.8 N·m (5 ft. lbs.) increments until proper rotating torque is achieved.

CAUTION: If the maximum tightening torque is reached prior to reaching the required rotating torque, the collapsible spacer may have been damaged. Replace the collapsible spacer.

REMOVAL AND INSTALLATION (Continued)

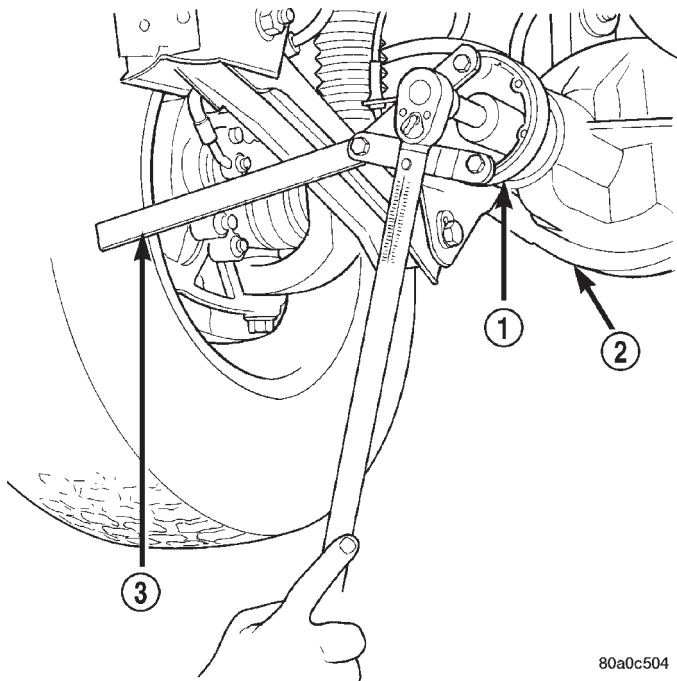

80a0c504

Fig. 13 Tightening Pinion Shaft Nut

- 1 - PINION FLANGE
- 2 - FRONT AXLE
- 3 - TOOL 6958

(6) Align the installation reference marks on the propeller shaft and pinion companion flange and install the propeller shaft.

(7) Check and fill the gear lubricant. Refer to the Lubricant Specifications for gear lubricant requirements.

(8) Install the brake rotors and calipers. Refer to Group 5, Brakes, for proper procedures.

(9) Install wheel and tire assemblies.

(10) Lower the vehicle.

COLLAPSIBLE SPACER

REMOVAL W/PINION INSTALLED

- (1) Raise and support the vehicle.
- (2) Remove wheel and tire assemblies.
- (3) Remove brake rotors and calipers. Refer to Group 5, Brakes, for proper procedures.
- (4) Mark the propeller shaft and pinion companion flange for installation reference.
- (5) Remove the propeller shaft from the pinion companion flange.
- (6) Rotate the pinion gear a minimum of ten times. Verify that the pinion rotates smoothly.
- (7) Measure the amount of torque necessary to rotate the pinion gear with a (in. lbs.) dial-type torque wrench. Record the torque reading for installation reference.

(8) Using a short piece of pipe and Holder 6958 to hold the pinion companion flange, remove the pinion nut and washer.

(9) Use Remover C-452 and Wrench C-3281 to remove the pinion companion flange.

(10) Use Remover 7794-A and slide hammer to remove the pinion shaft seal (Fig. 14).

(11) Remove the front pinion bearing using a pair of suitable pick tools to pull the bearing straight off the pinion gear shaft. It may be necessary to lightly tap the end of the pinion gear with a rawhide or rubber mallet if the bearing becomes bound on the pinion shaft.

(12) Remove the collapsible spacer.

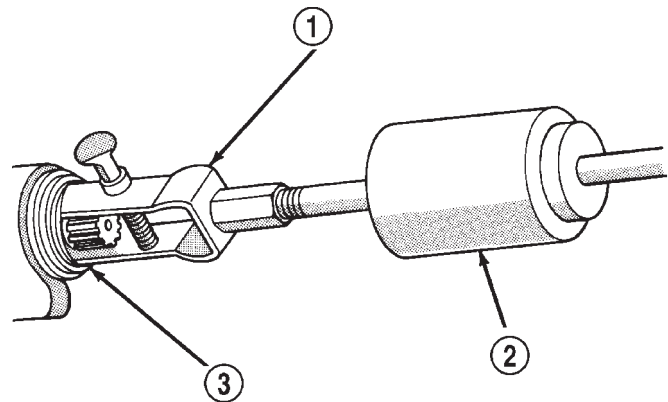

J9402-59X

Fig. 14 Seal Removal

- 1 - SPECIAL TOOL 7794A
- 2 - SLIDE HAMMER
- 3 - PINION SEAL

REMOVAL W/PINION REMOVED

- (1) Raise and support the vehicle.
- (2) Remove wheel and tire assemblies.
- (3) Remove brake rotors and calipers. Refer to Group 5, Brakes, for proper procedures.
- (4) Mark the propeller shaft and pinion companion flange, for installation reference.
- (5) Remove the propeller shaft from the pinion companion flange.
- (6) Rotate the pinion gear a minimum of ten times. Verify that the pinion rotates smoothly.
- (7) Measure the amount of torque necessary to rotate the pinion gear with a (in. lbs.) dial-type torque wrench. Record the torque reading for installation reference.
- (8) Remove differential assembly from axle housing.
- (9) Using Holder 6958 and a short length of 1 in. pipe to hold the pinion companion flange, remove the pinion nut and washer.

REMOVAL AND INSTALLATION (Continued)

(10) Using Remover C-452 and Wrench C-3281, remove the pinion companion flange from pinion shaft.

(11) Remove the pinion gear from housing (Fig. 15). Catch the pinion with your hand to prevent it from falling and being damaged.

(12) Remove collapsible spacer from pinion shaft.

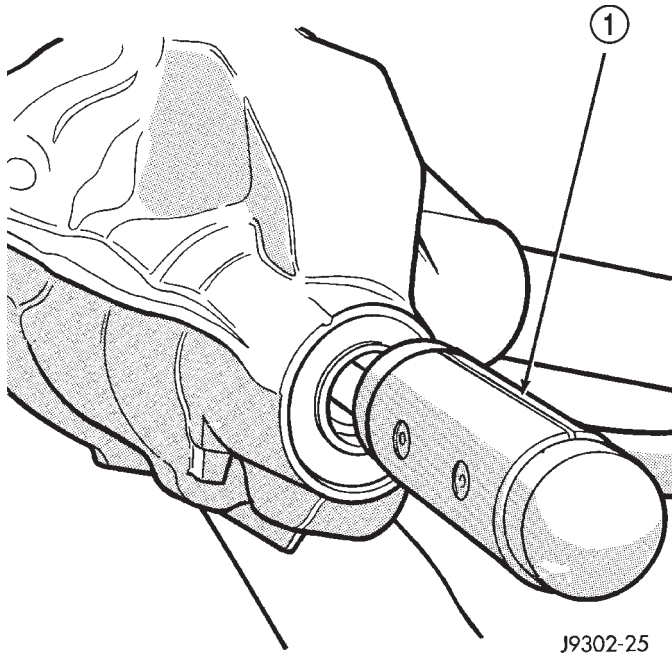

J9302-25

Fig. 15 Remove Pinion Gear

1 - RAWHIDE HAMMER

INSTALLATION

(1) Install a new collapsible preload spacer on pinion shaft (Fig. 16).

(2) If pinion gear was removed, install pinion gear in housing.

(3) Install pinion front bearing, if necessary.

(4) Apply a light coating of gear lubricant on the lip of pinion seal. Install seal with Installer 8108 and Handle C-4171 (Fig. 17), if necessary.

(5) Install pinion companion flange with Installer W-162-D, Cup 8109, and Flange Holder 6958.

(6) If the original pinion bearings are being used, install differential assembly and axle shafts, if necessary.

NOTE: If new pinion bearings were installed, do not install the differential assembly and axle shafts until after the pinion bearing preload and rotating torque are set.

(7) Install the pinion washer and a new nut on the pinion gear. Tighten the nut to 217 N·m (160 ft. lbs.) minimum. **Do not overtighten.** Maximum torque is 353 N·m (260 ft. lbs.).

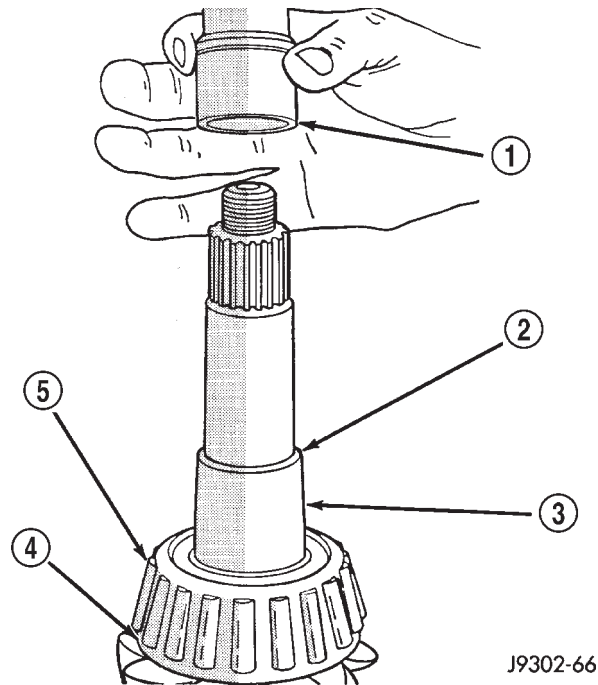

J9302-66

Fig. 16 Collapsible Preload Spacer

- 1 - COLLAPSIBLE SPACER
- 2 - SHOULDER
- 3 - PINION GEAR
- 4 - OIL SLINGER
- 5 - REAR BEARING

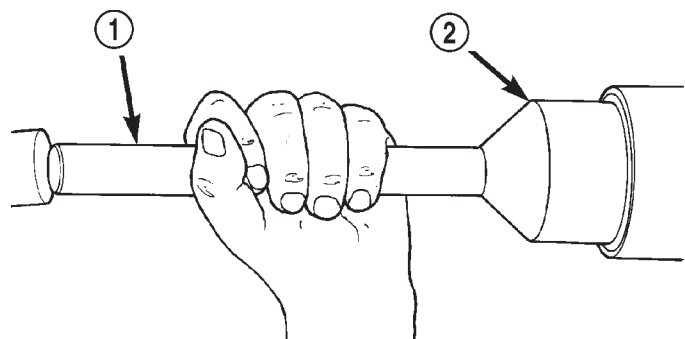

80a98349

Fig. 17 Pinion Seal Installation

- 1 - SPECIAL TOOL C-4171
- 2 - SPECIAL TOOL C-8108

CAUTION: Never loosen pinion gear nut to decrease pinion gear bearing rotating torque and never exceed specified preload torque. If preload torque is exceeded a new collapsible spacer must be installed. The torque sequence will then have to be repeated.

REMOVAL AND INSTALLATION (Continued)

NOTE: If the spacer requires more than 353 N·m (260 ft. lbs.) of torque to crush, the collapsible spacer is defective and must be replaced.

(8) Using Flange Holder 6958, a short length of 1 in. pipe, and a torque wrench set at 353 N·m (260 ft. lbs.), crush collapsible spacer until bearing end play is taken up (Fig. 18).

(9) Slowly tighten the nut in 6.8 N·m (5 ft. lbs.) increments until the required rotating torque is achieved. Measure the rotating torque frequently to avoid over crushing the collapsible spacer (Fig. 19).

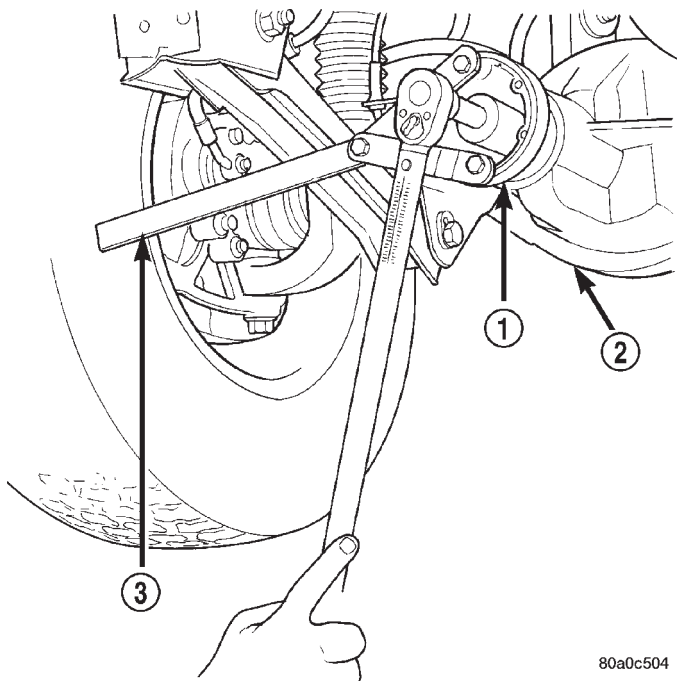

Fig. 18 Tightening Pinion Nut

- 1 - PINION FLANGE
- 2 - FRONT AXLE
- 3 - TOOL 6958

(10) Rotate the pinion gear a minimum of ten times. Verify that the pinion rotates smoothly. Check rotating torque with an inch pound torque wrench (Fig. 19). The torque necessary to rotate the pinion gear should be:

- Original Bearings — The reading recorded during removal, plus an additional 0.56 N·m (5 in. lbs.).
- New Bearings — 1 to 2.8 N·m (10 to 25 in. lbs.).

(11) Install differential assembly and axle shafts, if necessary.

(12) Align marks made previously on pinion companion flange and propeller shaft and install propeller shaft.

(13) Install brake rotors and calipers. Refer to Group 5, Brakes, for proper procedures.

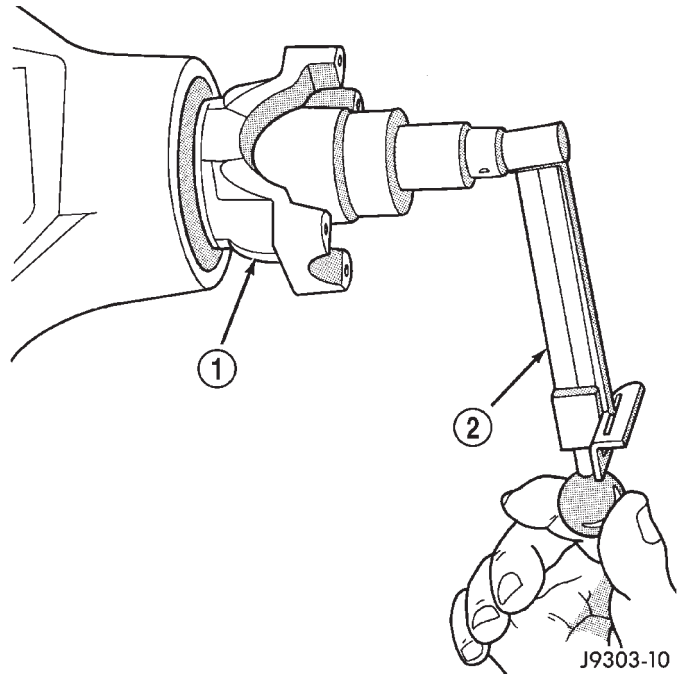

Fig. 19 Check Pinion Gear Rotation Torque—Typical

- 1 - PINION YOKE
- 2 - INCH POUND TORQUE WRENCH

(14) Add gear lubricant, if necessary. Refer to Lubricant Specifications of this section for lubricant requirements.

(15) Install wheel and tire assemblies.

(16) Lower vehicle.

HUB BEARING AND AXLE SHAFT

If the axle shaft and hub bearing are being removed in order to service another component, the axle shaft and hub bearing can be removed as an assembly.

REMOVAL

- (1) Raise and support the vehicle.
- (2) Remove the wheel and tire assembly.
- (3) Remove the brake caliper and rotor. Refer to Group 5, Brakes, for proper procedures.
- (4) Remove ABS wheel speed sensor, if necessary. Refer to Group 5, Brakes, for proper procedures.
- (5) Remove the cotter pin, nut retainer, and axle hub nut (Fig. 20), if necessary.
- (6) Remove the hub to knuckle bolts (Fig. 21).
- (7) Remove the hub from the steering knuckle and axle shaft, if necessary.
- (8) Remove hub bearing and axle shaft assembly (Fig. 22), or axle shaft from axle. **Avoid damaging the axle shaft oil seals in the axle housing.**
- (9) Remove the brake rotor shield from the hub bearing or knuckle (Fig. 20).

REMOVAL AND INSTALLATION (Continued)

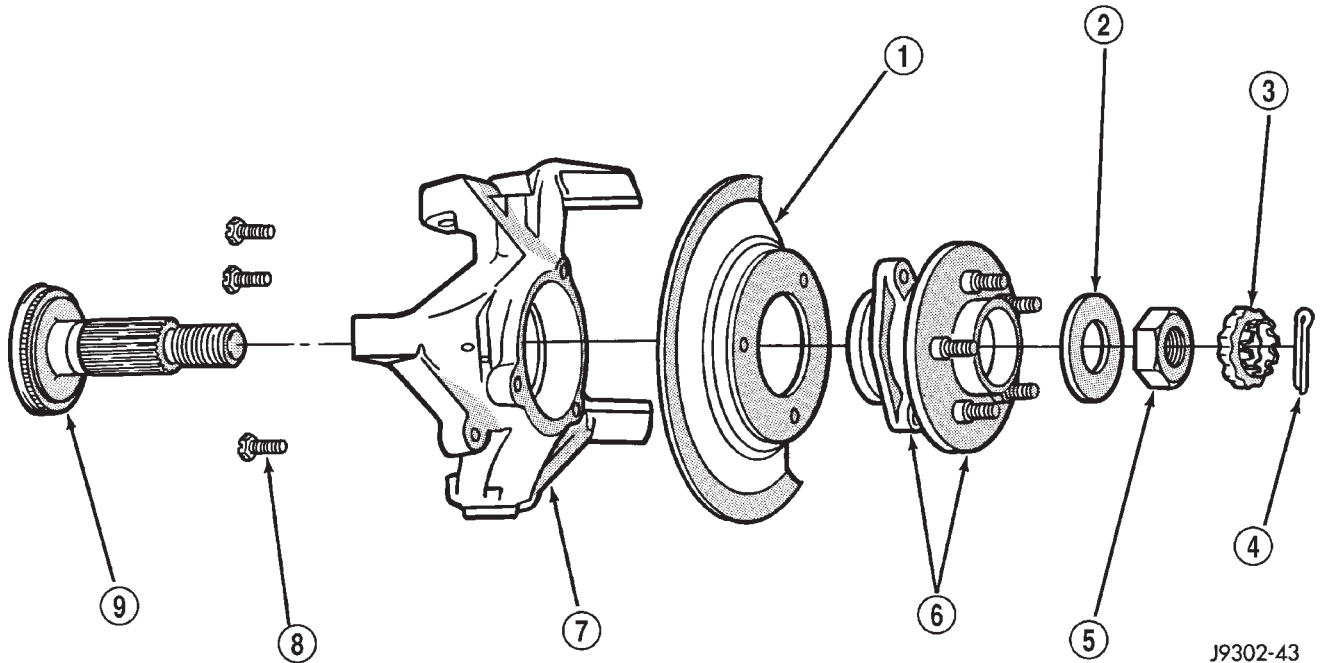

J9302-43

Fig. 20 Hub, Knuckle and Axle Shaft

- | | |
|------------------|------------------------------|
| 1 - BRAKE SHIELD | 6 - HUB AND BEARING ASSEMBLY |
| 2 - WASHER | 7 - STEERING KNUCKLE |
| 3 - RETAINER | 8 - BOLT |
| 4 - COTTER PIN | 9 - TONE WHEEL (ABS) |
| 5 - NUT | |

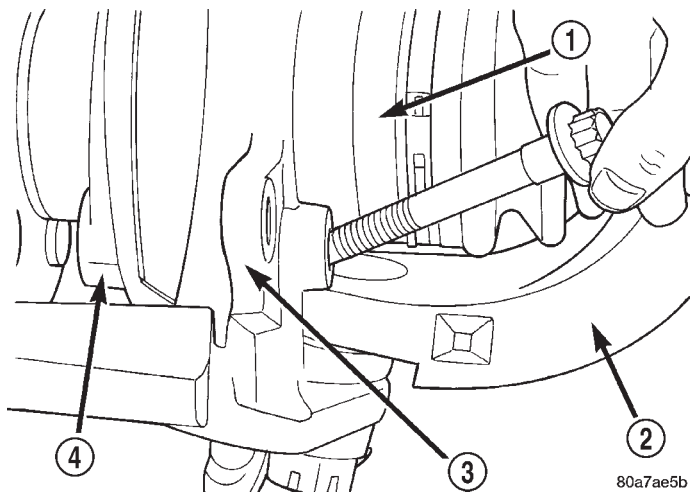

Fig. 21 Hub Bearing Bolts

- | |
|-----------------|
| 1 - AXLE SHAFT |
| 2 - AXLE |
| 3 - KNUCKLE |
| 4 - HUB BEARING |

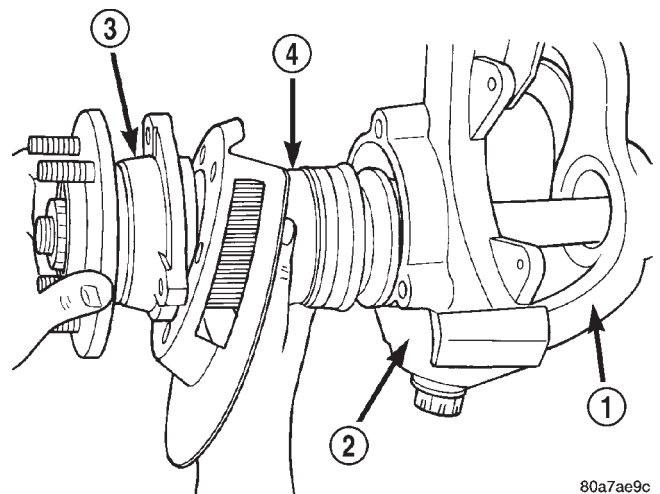

Fig. 22 Hub Bearing and Axle Assembly

- | |
|-----------------|
| 1 - AXLE |
| 2 - KNUCKLE |
| 3 - HUB BEARING |
| 4 - AXLE SHAFT |

INSTALLATION

(1) Thoroughly clean the axle shaft (Fig. 20) and apply a thin film of Mopar® Wheel Bearing Grease,

or equivalent, to the shaft splines, seal contact surface, and hub bore.

(2) Install the brake rotor shield to the knuckle.

REMOVAL AND INSTALLATION (Continued)

(3) Install the hub bearing and axle shaft assembly, or axle shaft, into the housing and differential side gears. Avoid damaging the axle shaft oil seals in the axle housing.

(4) Install the hub bearing, if necessary.

(5) Install the hub to knuckle bolts and tighten to 102 N·m (75 ft. lbs.) torque.

(6) Install the hub washer and nut, if necessary. Tighten the hub nut to 237 N·m (175 ft. lbs.) torque. Install the nut retainer and a new cotter pin (Fig. 20).

(7) Install ABS wheel speed sensor, if necessary. Refer to Group 5, Brakes, for proper procedures.

(8) Install the brake rotor and caliper. Refer to Group 5, Brakes, for proper procedures.

(9) Install the wheel and tire assembly.

(10) Remove support and lower the vehicle.

STEERING KNUCKLE AND BALL STUDS

Ball stud service procedures below require removal of the hub bearing and axle shaft. Removal and installation of upper and lower ball studs require the use of Tool Kit 6289.

KNUCKLE REMOVAL

(1) Remove hub bearing and axle shaft.

(2) Disconnect the tie-rod or drag link from the steering knuckle arm. Refer to Group 2, Suspension, for proper procedures.

(3) Remove the cotter pins from the upper and lower ball studs.

(4) Remove the upper and lower ball stud nuts.

(5) Strike the steering knuckle with a brass hammer to loosen knuckle from the ball studs. Remove knuckle from ball studs (Fig. 23).

UPPER BALL STUD REPLACEMENT

(1) Position tools as shown to remove and install ball stud (Fig. 24).

LOWER BALL STUD REPLACEMENT

(1) Position tools as shown to remove and install ball stud (Fig. 25).

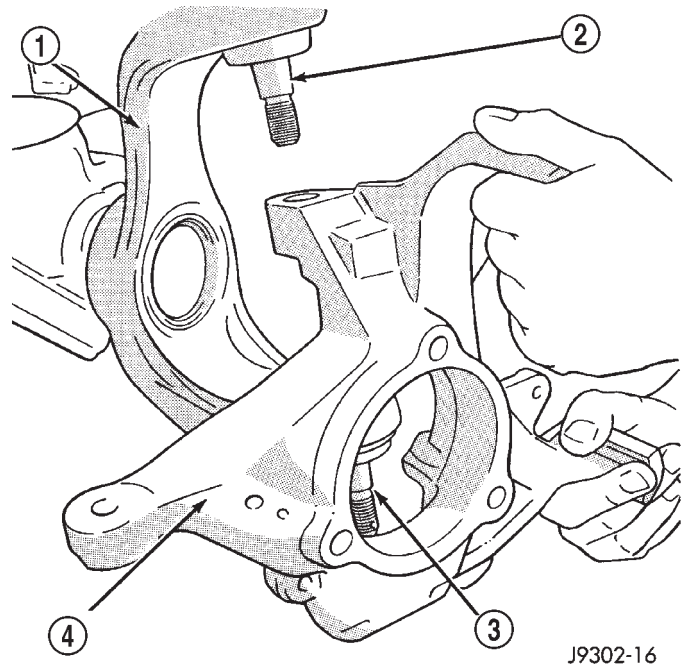

Fig. 23 Steering Knuckle Removal/Installation

- 1 - AXLE YOKE
- 2 - UPPER BALL STUD
- 3 - LOWER BALL STUD
- 4 - STEERING KNUCKLE

KNUCKLE INSTALLATION

(1) Position the steering knuckle on the ball studs.

(2) Install and tighten the bottom retaining nut to 109 N·m (80 ft. lbs.) torque. Install new cotter pin.

(3) Install and tighten the top retaining nut to 101 N·m (75 ft. lbs.) torque. Install new cotter pin.

(4) Install the hub bearing and axle shaft.

(5) Connect the tie-rod or drag link end to the steering knuckle arm. Refer to Group 2, Suspension, for proper procedures.

REMOVAL AND INSTALLATION (Continued)

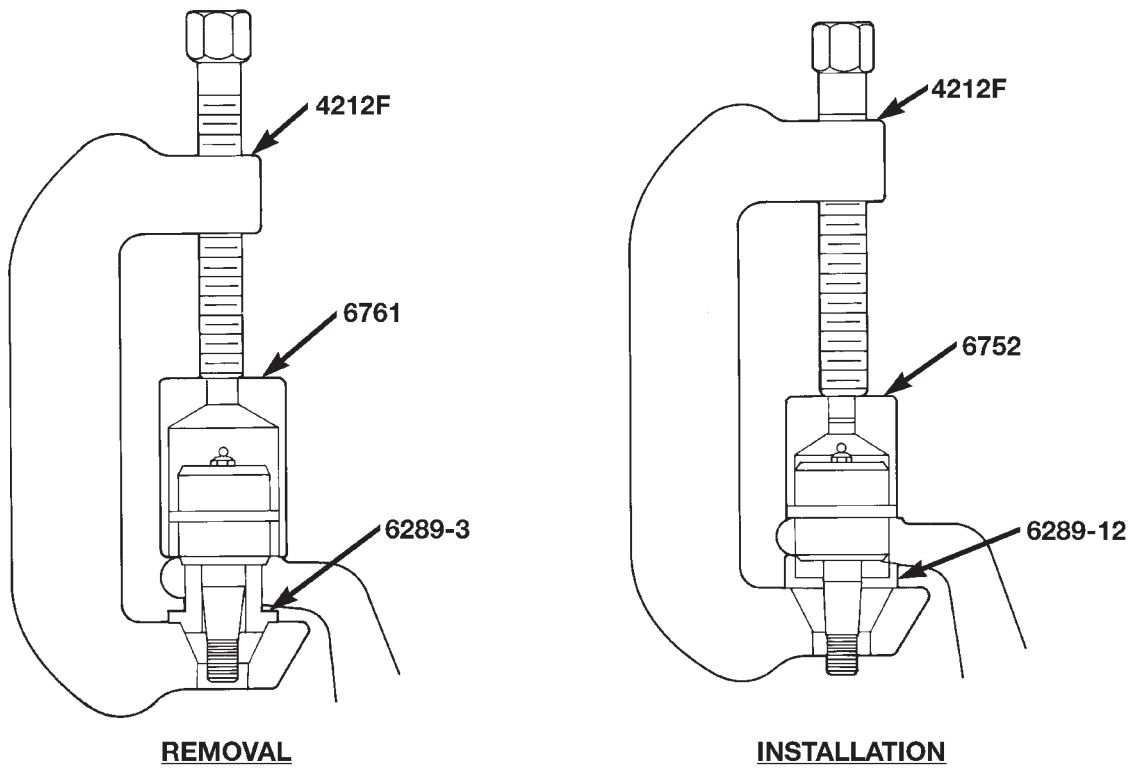

80a7e2a7

Fig. 24 Upper Ball Stud Remove/Install

REMOVAL AND INSTALLATION (Continued)

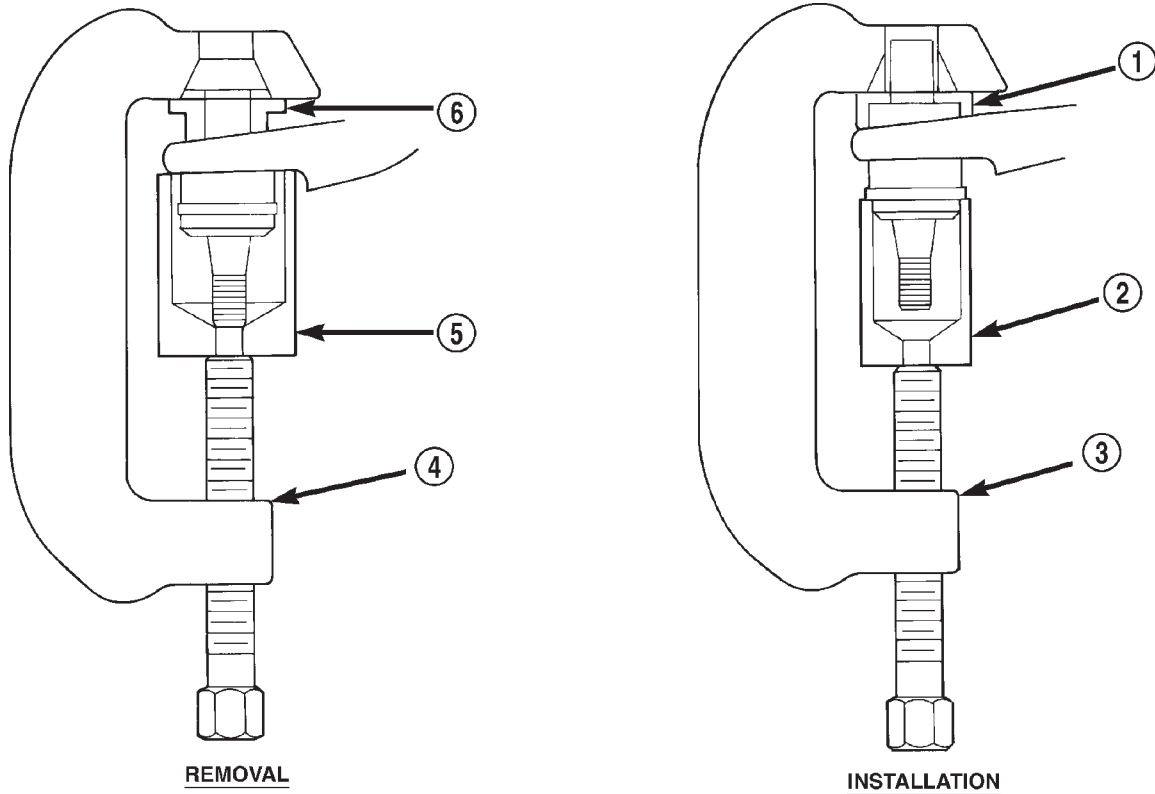

Fig. 25 Lower Ball Stud Remove/Install

- 1 - SPECIAL TOOL 6289-12
- 2 - SPECIAL TOOL 6289-4
- 3 - SPECIAL TOOL 4212F

- 4 - SPECIAL TOOL 4212F
- 5 - SPECIAL TOOL 6289-1
- 6 - SPECIAL TOOL 6289-3

80a7e2a8

AXLE BUSHING REPLACEMENT

Refer to Group 2, Suspension, for the proper axle bushing procedures.

DIFFERENTIAL

REMOVAL

- (1) Raise and support vehicle.
- (2) Remove the lubricant fill hole plug from the differential housing cover.
- (3) Remove the differential housing cover and allow fluid to drain.
- (4) Remove hub bearings and axle shafts.
- (5) Note the installation reference letters stamped on the bearing caps and housing machined sealing surface (Fig. 26).

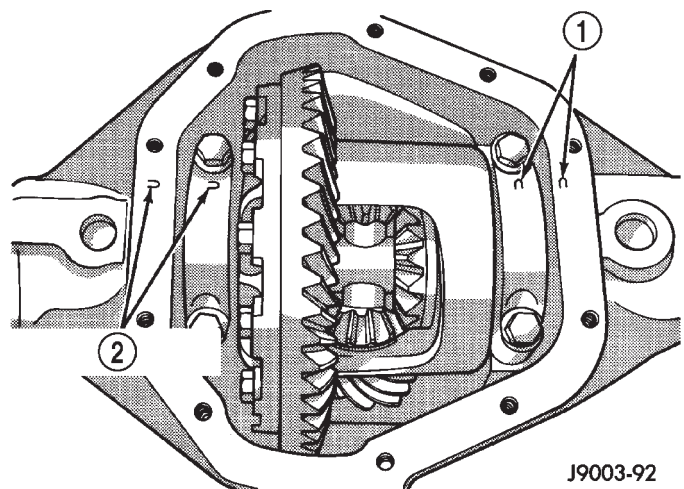

J9003-92

Fig. 26 Bearing Cap Identification

- 1 - INSTALLATION REFERENCE LETTERS
- 2 - INSTALLATION REFERENCE LETTERS

REMOVAL AND INSTALLATION (Continued)

(6) Loosen the differential bearing cap bolts.

(7) Position Spreader W-129-B, utilizing some items from Adapter Kit 6987, with the tool dowel pins seated in the locating holes (Fig. 27). Install the holddown clamps and tighten the tool turnbuckle finger-tight.

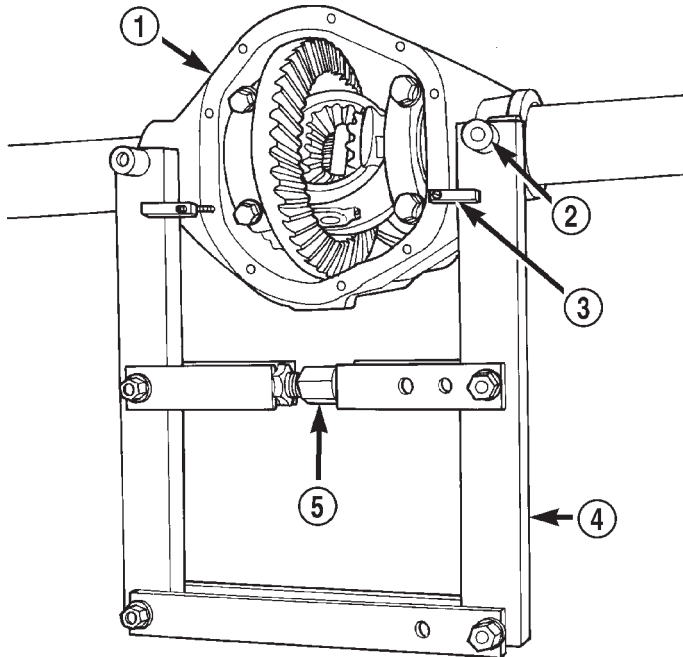

80a534c5

Fig. 27 Install Axle Housing Spreader

- 1 - AXLE HOUSING
- 2 - DOWEL
- 3 - SAFETY HOLD DOWN
- 4 - SPECIAL TOOL W-129-B
- 5 - TURNBUCKLE

(8) Install a Guide Pin C-3288-B at the left side of the differential housing. Attach Dial Indicator C-3339 to guide pin. Load the lever adapter against the opposite side of the housing (Fig. 28) and zero the indicator.

CAUTION: Do not spread over 0.50 mm (0.020 in). If the housing is over-spread, it could be distorted or damaged.

(9) Spread the housing enough to remove the differential case from the housing. Measure the distance with the dial indicator (Fig. 29).

(10) Remove the dial indicator.

(11) While holding the differential case in position, remove the differential bearing cap bolts and caps.

(12) Remove the differential from the housing. Ensure that the differential bearing cups remain in position on the differential bearings (Fig. 30).

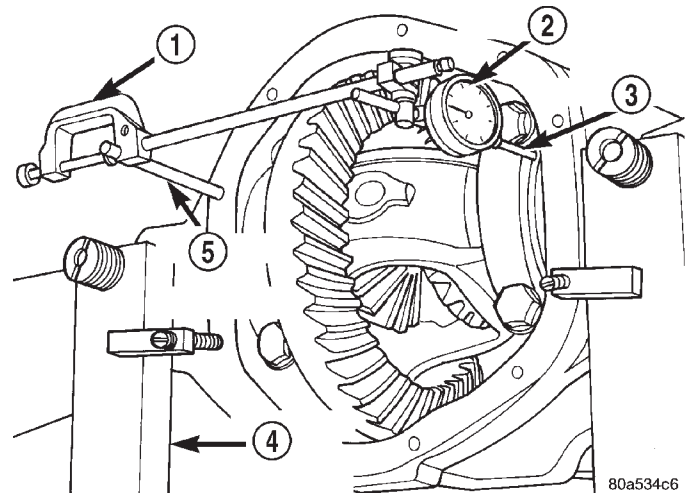

80a534c6

Fig. 28 Install Dial Indicator

- 1 - SPECIAL TOOL C-3339
- 2 - DIAL INDICATOR
- 3 - LEVER ADAPTER
- 4 - SPECIAL TOOL W-129-B
- 5 - SPECIAL TOOL C-3288-B

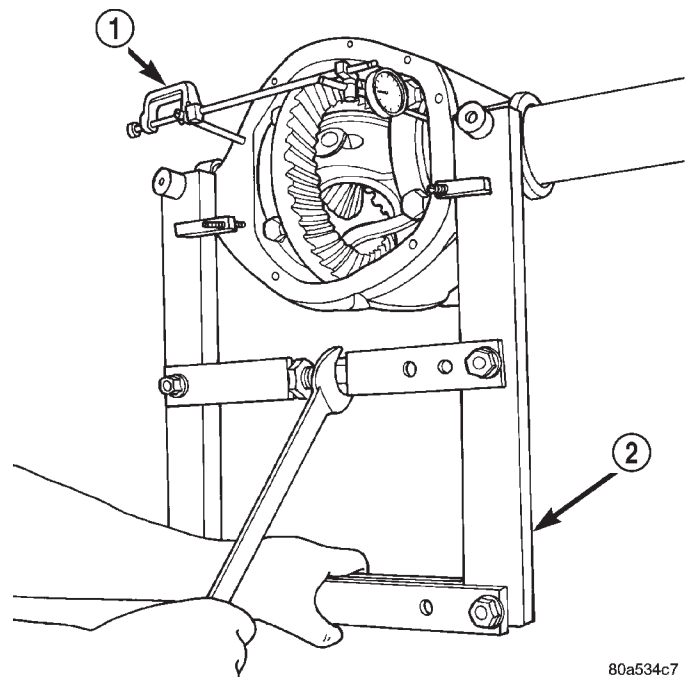

80a534c7

Fig. 29 Spread Axle Housing

- 1 - SPECIAL TOOL C-3339
- 2 - SPECIAL TOOL W-129-B

(13) Mark or tag the differential bearing cups to indicate which side of the differential they were removed from.

(14) Retrieve the differential case preload shims from the axle housing.

REMOVAL AND INSTALLATION (Continued)

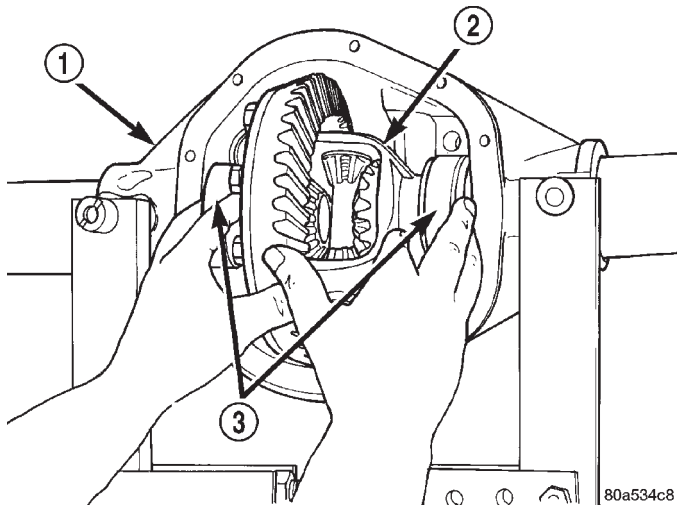

Fig. 30 Differential Case Removal

- 1 - AXLE HOUSING
- 2 - DIFFERENTIAL CASE
- 3 - BEARING CUPS

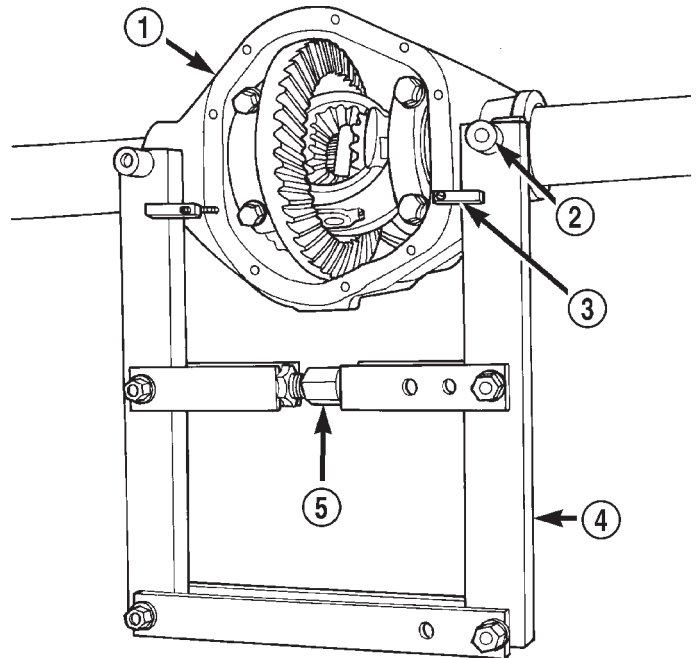

Fig. 31 Install Axle Housing Spreader

- 1 - AXLE HOUSING
- 2 - DOWEL
- 3 - SAFETY HOLD DOWN
- 4 - SPECIAL TOOL W-129-B
- 5 - TURNBUCKLE

(15) Remove spreader from housing. Mark or tag the differential bearing preload shims to indicate which side of the differential they were removed from.

INSTALLATION

If replacement differential bearings or differential case are being installed, differential side bearing shim requirements may change. Refer to the Differential Bearing Preload and Gear Backlash procedures in this section to determine the proper shim selection.

(1) Position Spreader W-129-B, utilizing some items from Adapter Kit 6987, with the tool dowel pins seated in the locating holes (Fig. 31). Install the holddown clamps and tighten the tool turnbuckle finger-tight.

(2) Install a Guide Pin C-3288-B at the left side of the differential housing. Attach Dial Indicator C-3339 to guide pin. Load the lever adapter against the opposite side of the housing (Fig. 28) and zero the indicator.

CAUTION: Do not spread over 0.50 mm (0.020 in). If the housing is over-spread, it could be distorted or damaged.

(3) Spread the housing enough to install the case in the housing. Measure the distance with the dial indicator (Fig. 29).

(4) Remove the dial indicator.

(5) Install differential case in the housing. Ensure that the differential bearing cups remain in position on the differential bearings and that the preload shims remain between the face of the bearing cup

and housing. Also verify that the pick-up opening of the Vari-lok™ plenum is at the bottom of the housing. Tap the differential case to ensure the bearings cups and shims are fully seated in the housing.

(6) Install the bearing caps at their original locations (Fig. 32).

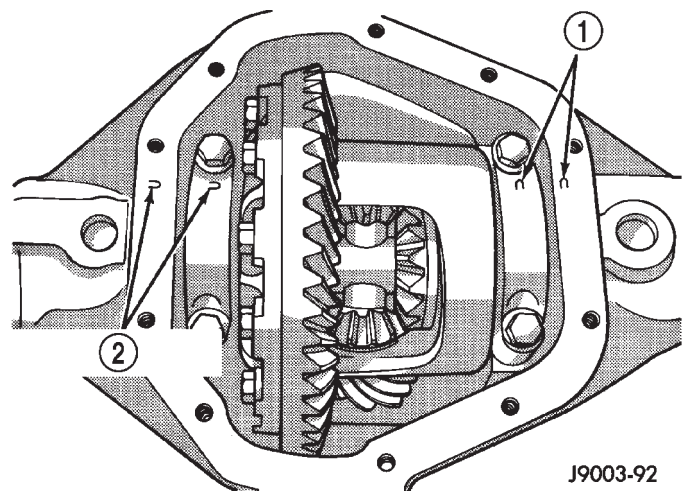

Fig. 32 Differential Bearing Cap Reference Letters

- 1 - INSTALLATION REFERENCE LETTERS
- 2 - INSTALLATION REFERENCE LETTERS

(7) Loosely install differential bearing cap bolts.

REMOVAL AND INSTALLATION (Continued)

- (8) Remove axle housing spreader.
- (9) Tighten the bearing cap bolts to 61 N·m (45 ft. lbs.) torque.
- (10) Install the hub bearings and axle shafts.

DIFFERENTIAL SIDE BEARINGS

REMOVAL

- (1) Remove differential case from axle housing.
- (2) Remove the bearings from the differential case with Puller/Press C-293-PA, Adapter Blocks 8352, and Plug SP-3289 (Fig. 33).

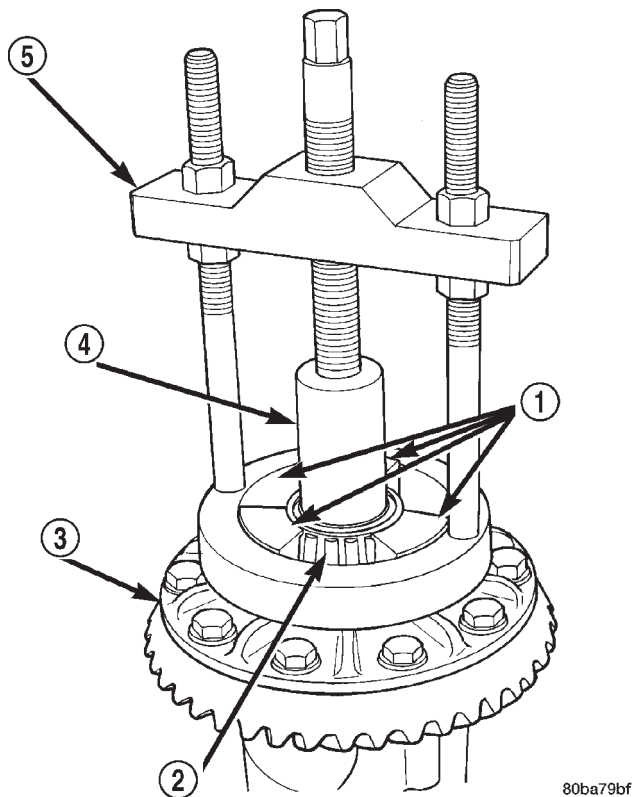

Fig. 33 Differential Bearing Removal

- 1 - SPECIAL TOOL 8352
- 2 - BEARING
- 3 - DIFFERENTIAL
- 4 - SPECIAL TOOL SP-3289
- 5 - SPECIAL TOOL C-293-PA

INSTALLATION

If replacement differential side bearings or differential case are being installed, differential side bearing shim requirements may change. Refer to the Differential Bearing Preload and Gear Backlash procedures in this section to determine the proper shim selection.

CAUTION: Be sure that the Vari-lok™ plenum is fully seated against the differential case prior to installing the ring gear side differential bearing.

- (1) Using Installer C-3716-A and Handle C-4171, install differential side bearings (Fig. 34).

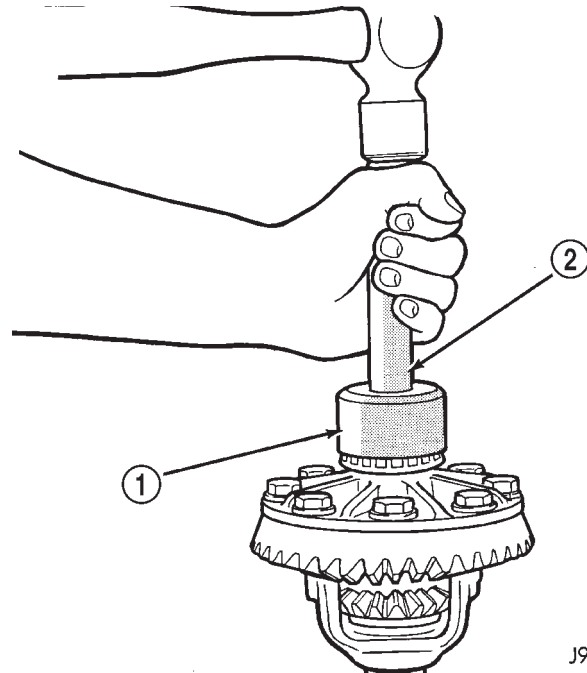

J9302-21

Fig. 34 Differential Side Bearing Installation

- 1 - SPECIAL TOOL C-3716-A
- 2 - SPECIAL TOOL C-4171

- (2) Install differential in axle housing.

VARI-LOK™ PLENUM

REMOVAL

- (1) Remove differential case from axle housing.
- (2) Remove the bearing from the ring gear side of the differential case with Puller/Press C-293-PA, Adapter Blocks 8352, and Plug SP-3289 (Fig. 35).
- (3) Remove the Vari-lok™ plenum from the differential case hub.

WARNING: Do not touch the Vari-lok™ tuning reed valve located under the Vari-lok™ plenum on the differential case. The metal is very sensitive and the unit will not operate properly if the reed valve is disturbed.

INSTALLATION

If a replacement differential side bearing is being installed, differential side bearing shim requirements may change. Refer to the Differential Bearing Preload and Gear Backlash procedures in this section to determine the proper shim selection.

- (1) Install a new Vari-lok™ plenum onto the differential case hub. The plenum is to be installed with

REMOVAL AND INSTALLATION (Continued)

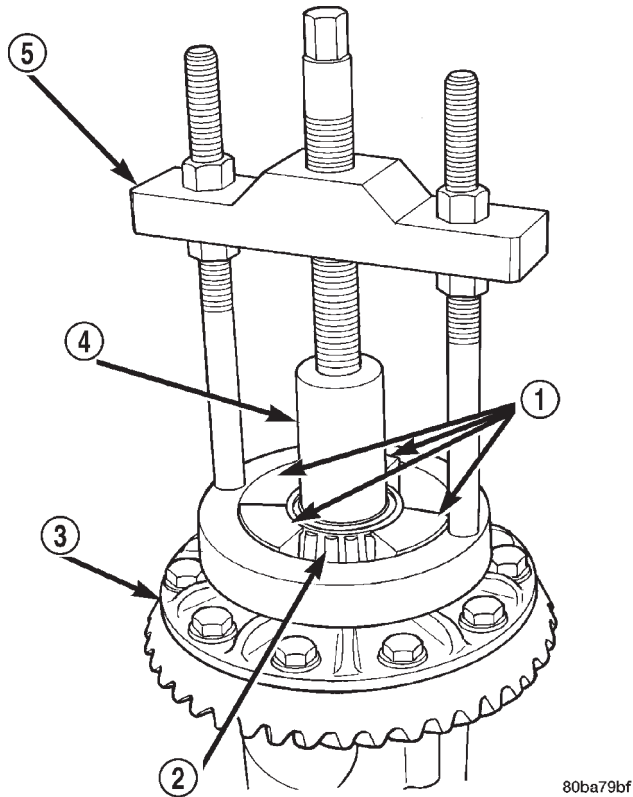

Fig. 35 Differential Bearing Removal

- 1 - SPECIAL TOOL 8352
- 2 - BEARING
- 3 - DIFFERENTIAL
- 4 - SPECIAL TOOL SP-3289
- 5 - SPECIAL TOOL C-293-PA

the rubber seal toward the differential case and the raised metal tabs away from the differential case.

CAUTION: Be sure that the Vari-lok™ plenum is fully seated against the differential case prior to installing the ring gear side differential bearing.

(2) Using Installer C-3716-A and Handle C-4171, install differential side bearing (Fig. 36).

(3) Install differential in axle housing.

AXLE SHAFT OIL SEAL

REMOVAL

- (1) Raise and support vehicle.
- (2) Remove differential assembly.
- (3) Remove the inner axle shaft seals with a pry bay.

INSTALLATION

(1) Remove any sealer remaining from original seals.

(2) Remove sealer from axle tube to housing junction, if necessary.

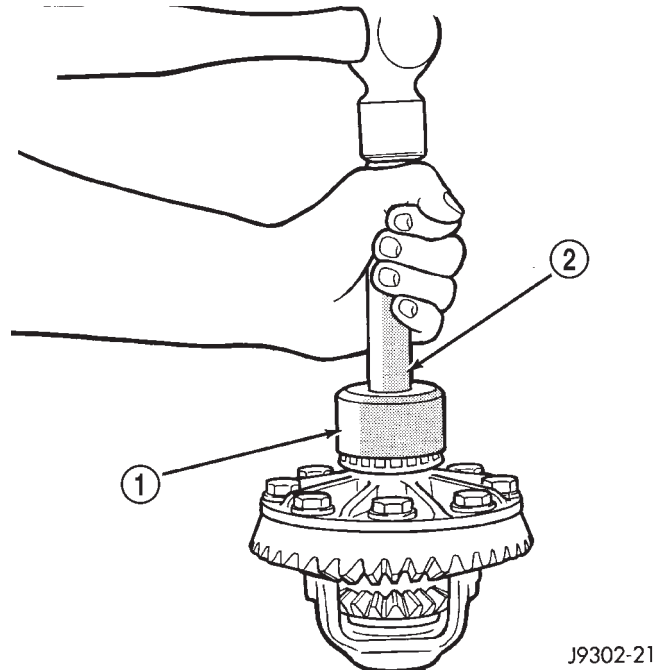

Fig. 36 Differential Side Bearing Installation

- 1 - SPECIAL TOOL C-3716-A
- 2 - SPECIAL TOOL C-4171

(3) Install oil seals with Discs 8110 and Turnbuckle 6797 (Fig. 37). Tighten tool until disc bottoms in housing.

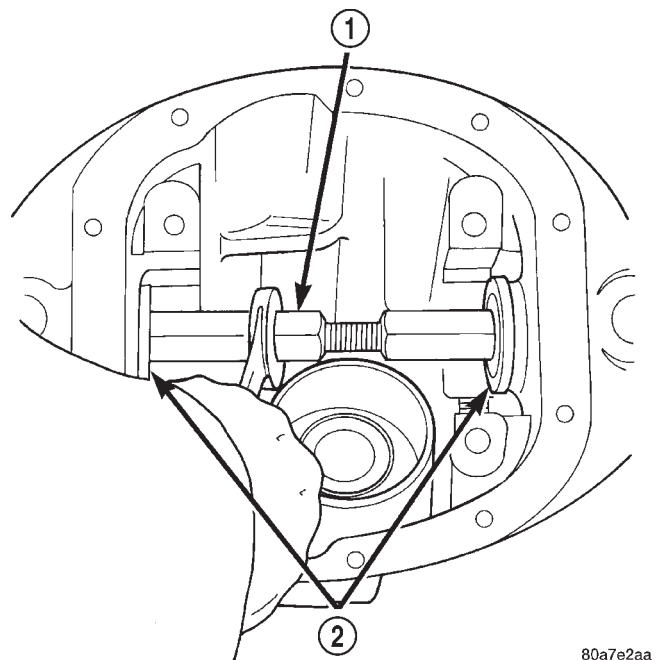

Fig. 37 Axle Seal Installation

- 1 - TURNBUCKLE 6797
- 2 - DISCS 8110

(4) Install differential assembly.

REMOVAL AND INSTALLATION (Continued)

PINION GEAR

NOTE: The ring and pinion gears are serviced as a matched set. Do not replace the pinion gear without replacing the ring gear.

REMOVAL

(1) Remove differential assembly from axle housing.

(2) Mark pinion companion flange and propeller shaft for installation alignment.

(3) Disconnect propeller shaft from pinion companion flange. Using suitable wire, tie propeller shaft to underbody.

(4) Using Holder 6958 to hold pinion companion flange, and a short length of 1 in. pipe, remove the pinion nut and washer (Fig. 38).

(5) Using Remover C-452 and Holder C-3281, remove the pinion companion flange from pinion shaft.

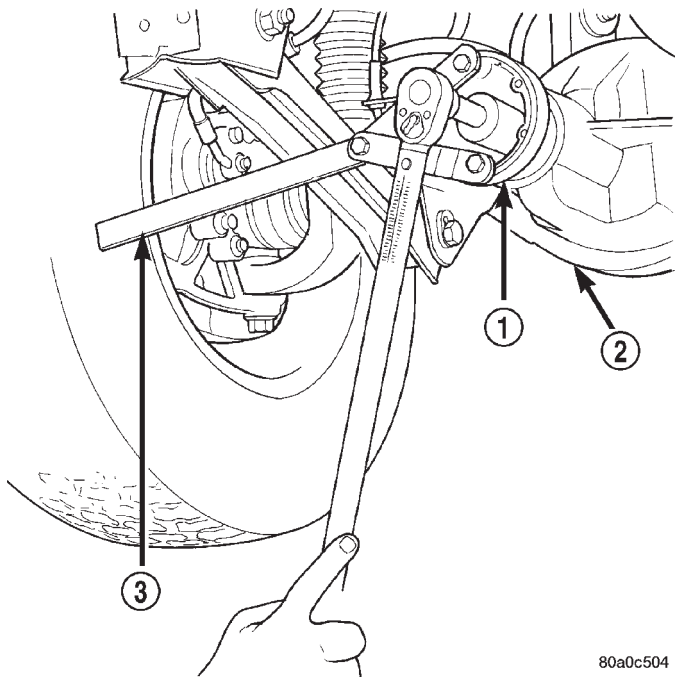

Fig. 38 Pinion Nut Removal

- 1 - PINION FLANGE
- 2 - FRONT AXLE
- 3 - TOOL 6958

(6) Remove the pinion gear and collapsible spacer from housing (Fig. 39). Catch the pinion with your hand to prevent it from falling and being damaged.

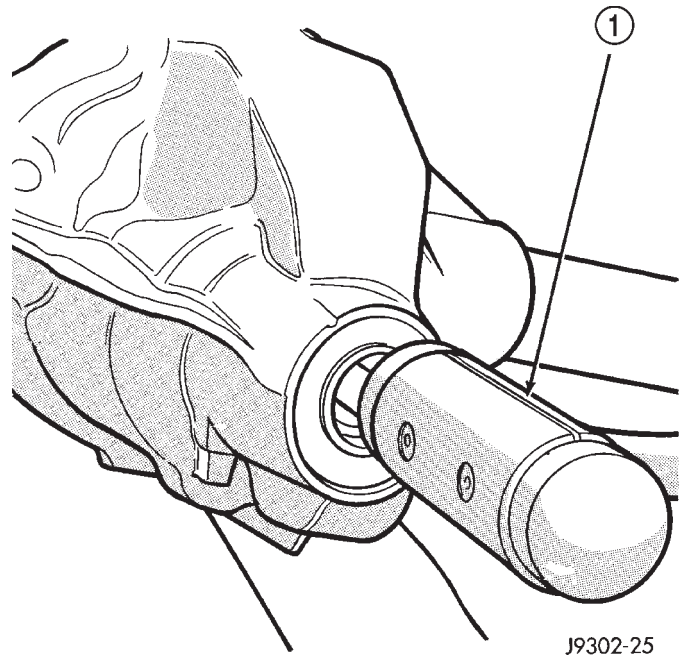

Fig. 39 Remove Pinion Gear

- 1 - RAWHIDE HAMMER

(7) Remove the front pinion bearing cup, bearing, oil slinger, and pinion seal with Remover C-4345 and Handle C-4171 (Fig. 40).

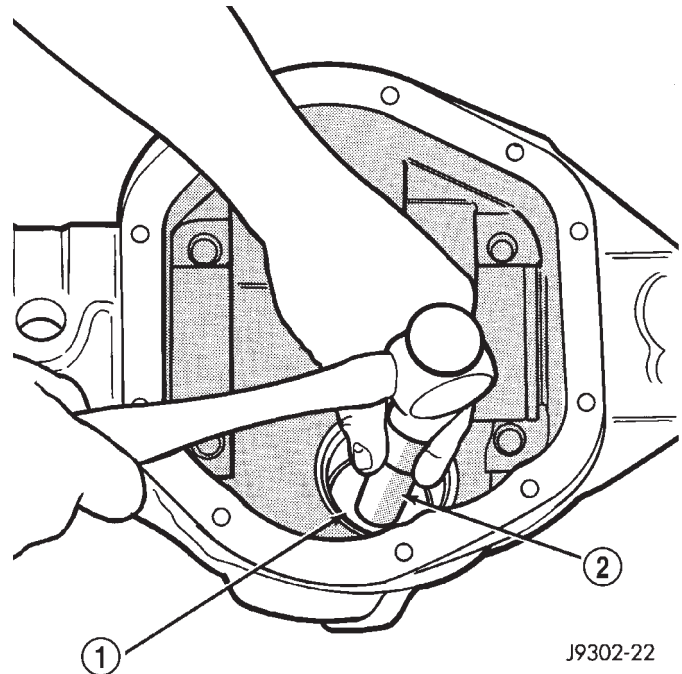

Fig. 40 Front Bearing Cup Removal

- 1 - REMOVER
- 2 - HANDLE

REMOVAL AND INSTALLATION (Continued)

(8) Remove the rear pinion bearing cup from axle housing (Fig. 41). Use Remover D-149 and Handle C-4171.

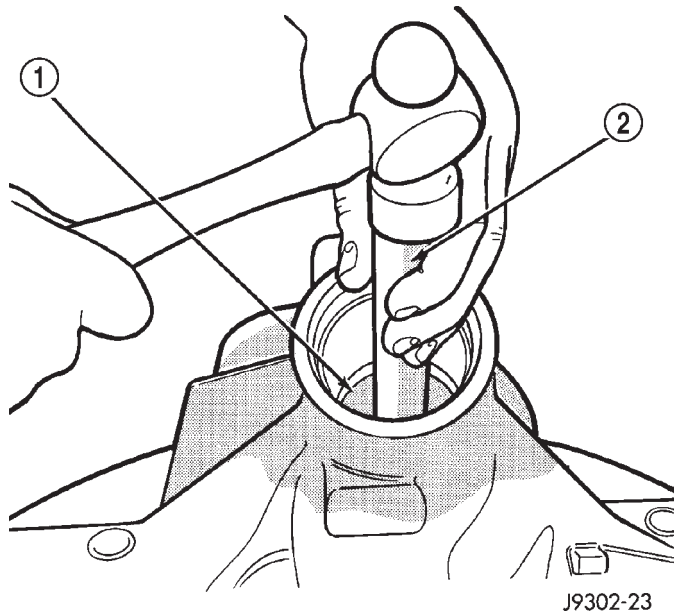

Fig. 41 Rear Bearing Cup Removal

- 1 - DRIVER
- 2 - HANDLE

(9) Remove the collapsible preload spacer from pinion gear (Fig. 42).

(10) Remove the rear pinion bearing from the pinion with Puller/Press C-293-PA and Adapters C-293-39 (Fig. 43). Remove the oil slinger/pinion depth shim from the pinion shaft. Record the thickness of the oil slinger/depth shim.

Place 4 adapter blocks so they do not damage the bearing cage.

INSTALLATION

NOTE: Pinion depth shims are placed between the rear pinion bearing cone and the pinion head to achieve proper ring and pinion gear mesh. If the factory installed ring and pinion gears are reused, the pinion oil slinger/depth shim should not require replacement. Refer to Pinion Gear Depth to select the proper thickness shim before installing pinion gear.

(1) Apply Mopar® Door Ease, or equivalent, stick lubricant to outside surface of rear pinion bearing cup. Install the bearing cup with Installer D-146 and Driver Handle C-4171 (Fig. 44). Verify cup is correctly seated.

(2) Apply Mopar® Door Ease, or equivalent, stick lubricant to outside surface of front pinion bearing

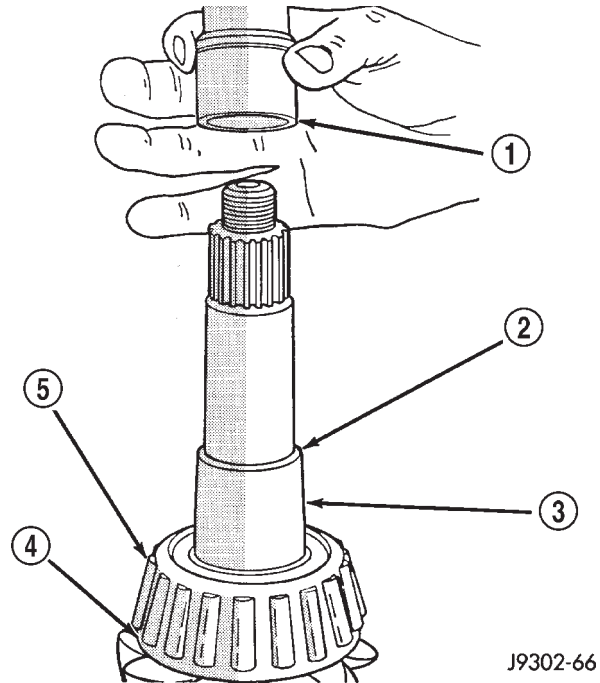

Fig. 42 Collapsible Spacer

- 1 - COLLAPSIBLE SPACER
- 2 - SHOULDER
- 3 - PINION GEAR
- 4 - OIL SLINGER
- 5 - REAR BEARING

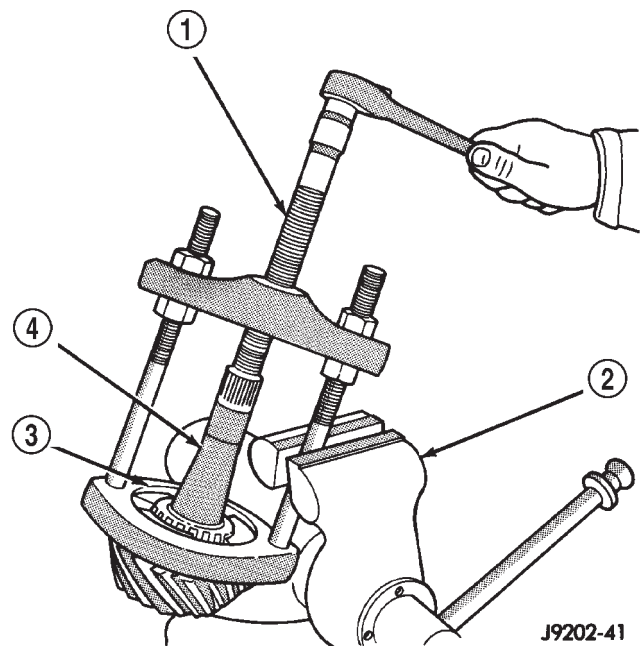
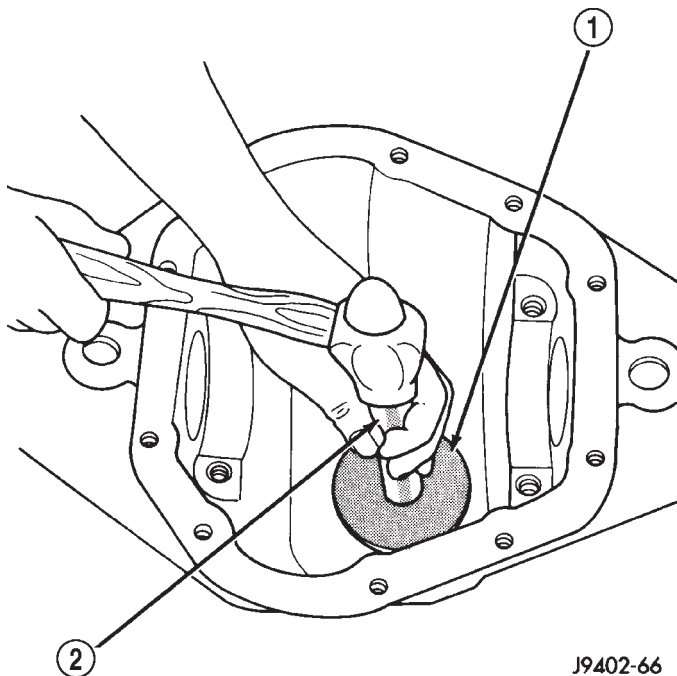

Fig. 43 Inner Bearing Removal

- 1 - SPECIAL TOOL C-293-PA
- 2 - VISE
- 3 - ADAPTERS
- 4 - DRIVE PINION GEAR SHAFT

REMOVAL AND INSTALLATION (Continued)



J9402-66

Fig. 44 Rear Pinion Bearing Cup Installation

- 1 - INSTALLER
- 2 - HANDLE

cup. Install the bearing cup with Installer D-130 and Handle C-4171 (Fig. 45).

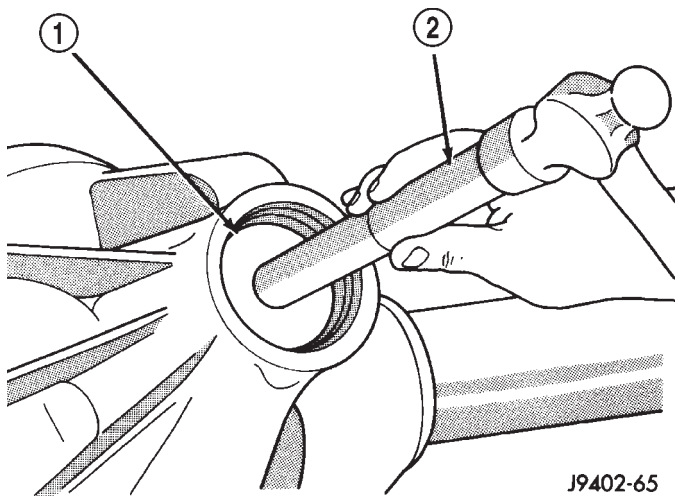

J9402-65

Fig. 45 Pinion Outer Bearing Cup Installation

- 1 - INSTALLER
- 2 - HANDLE

(3) Install front pinion bearing, and oil slinger, if equipped.

(4) Apply a light coating of gear lubricant on the lip of pinion seal. Install seal with Installer 8108 and Handle C-4171 (Fig. 46).

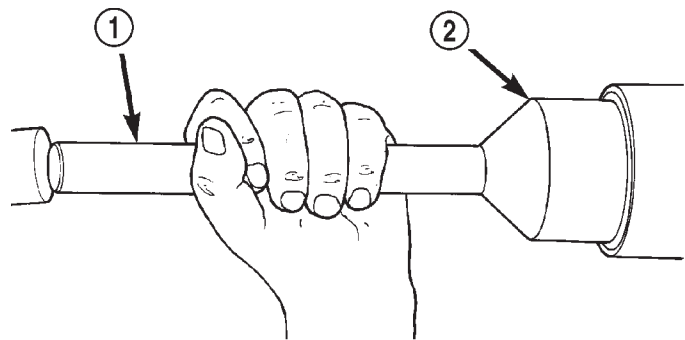

80a98349

Fig. 46 Pinion Seal Installation

- 1 - SPECIAL TOOL C-4171
- 2 - SPECIAL TOOL C-8108

(5) Install the rear pinion bearing and oil slinger/depth shim onto the pinion shaft with Installer W-262 and a shop press (Fig. 47).

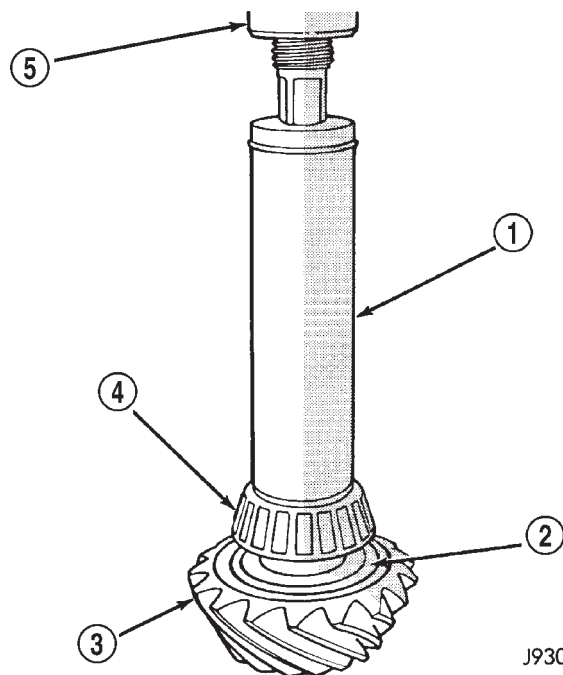

J9302-68

Fig. 47 Rear Pinion Bearing Installation

- 1 - INSTALLATION TOOL
- 2 - OIL SLINGER
- 3 - DRIVE PINION GEAR
- 4 - DRIVE PINION GEAR SHAFT REAR BEARING
- 5 - PRESS

(6) Install a new collapsible preload spacer on pinion shaft and install the pinion in the axle housing (Fig. 48).

(7) Install pinion companion flange, with Installer W-162-B, Cup 8109, and Holder 6958.

(8) Install the pinion washer and a new nut onto the pinion gear. Tighten the nut to 216 N·m (160 ft.

REMOVAL AND INSTALLATION (Continued)

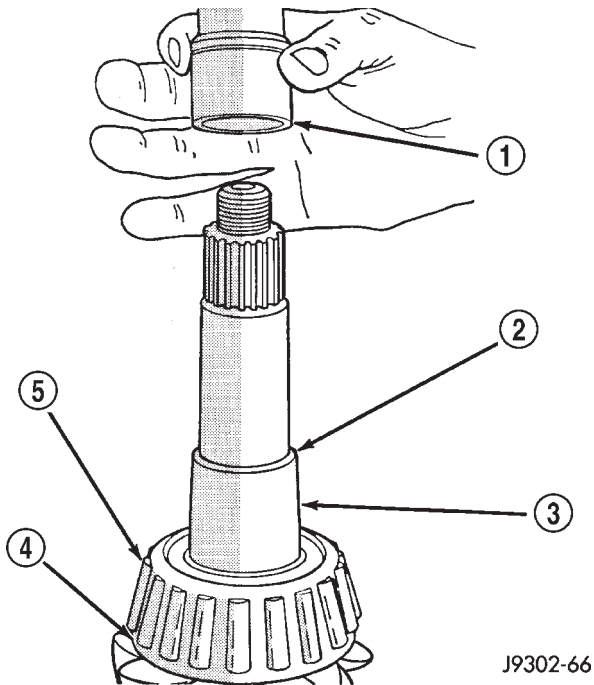

J9302-66

Fig. 48 Collapsible Preload Spacer

- 1 - COLLAPSIBLE SPACER
- 2 - SHOULDER
- 3 - PINION GEAR
- 4 - OIL SLINGER
- 5 - REAR BEARING

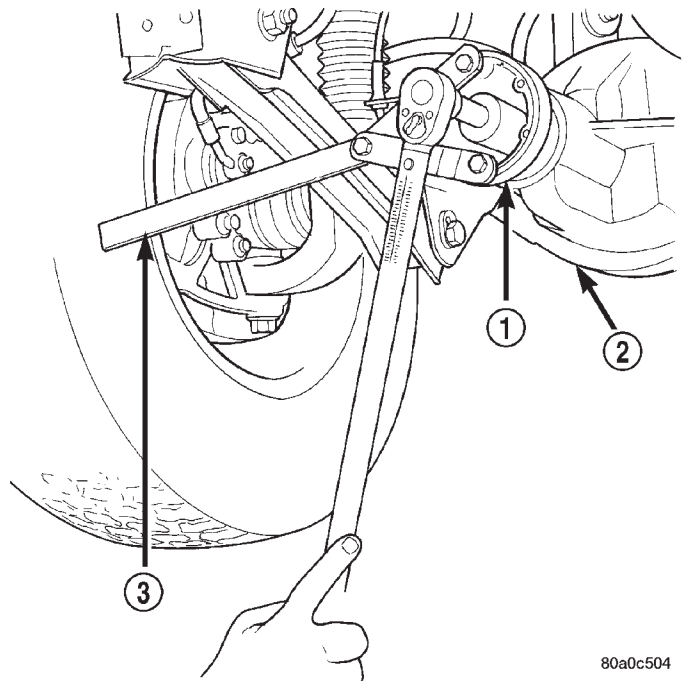

80a0c504

Fig. 49 Tightening Pinion Nut

- 1 - PINION FLANGE
- 2 - FRONT AXLE
- 3 - TOOL 6958

lbs.) minimum. **Do not over-tighten.** Maximum torque is 352 N·m (260 ft. lbs.).

CAUTION: Never loosen pinion gear nut to decrease pinion gear bearing rotating torque and never exceed specified preload torque. If preload torque is exceeded a new collapsible spacer must be installed. The torque sequence will then have to be repeated.

NOTE: If the spacer requires more than 352 N·m (260 ft. lbs.) of torque to crush, the collapsible spacer is defective.

(9) Using Holder 6958, a short length of 1 in. pipe, and torque wrench (set at 352 N·m (260 ft. lbs.)), crush collapsible spacer until bearing end play is taken up (Fig. 49).

(10) Slowly tighten the nut in 6.8 N·m (5 ft. lb.) increments until the required rotating torque is achieved. Measure the rotating torque frequently to avoid over crushing the collapsible spacer (Fig. 50).

(11) Rotate the pinion a minimum of ten times. Verify that the pinion rotates smoothly. Check bearing rotating torque with an inch pound torque wrench (Fig. 50). The torque necessary to rotate the pinion gear should be:

- Original Bearings — 1 to 2.25 N·m (10 to 20 in. lbs.).
- New Bearings — 1 to 2.8 N·m (10 to 25 in. lbs.).

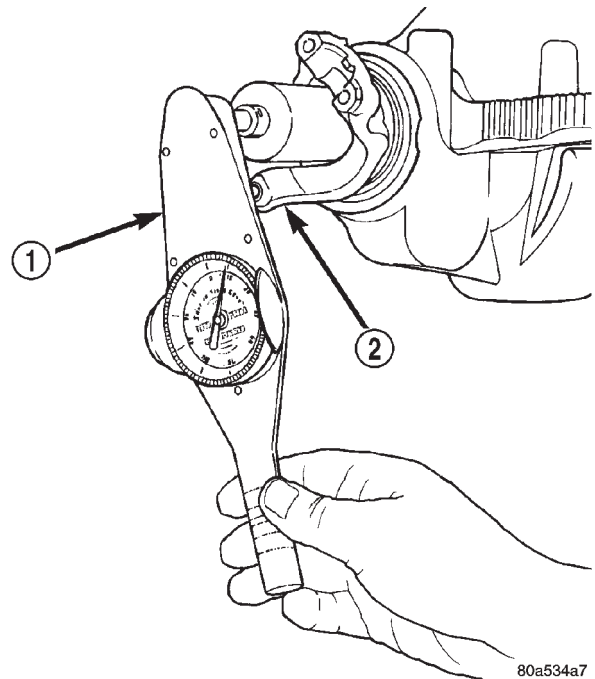

80a534a7

Fig. 50 Check Pinion Gear Rotation Torque-Typical

- 1 - in. lbs. TORQUE WRENCH
- 2 - PINION YOKE

REMOVAL AND INSTALLATION (Continued)

(12) Install differential assembly.

RING GEAR

NOTE: The ring gear and pinion are serviced as a matched set. Do not replace the ring gear without replacing the pinion.

REMOVAL

- (1) Remove differential from axle housing.
- (2) Place differential case in a suitable vise with soft metal jaw protectors. (Fig. 51)
- (3) Remove bolts holding ring gear to differential case.
- (4) Using a soft hammer, drive ring gear from differential case (Fig. 51).

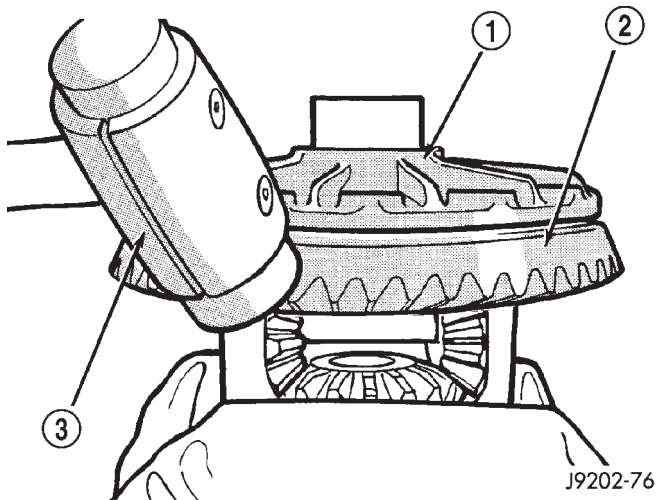

Fig. 51 Ring Gear Removal

- 1 - CASE
- 2 - RING GEAR
- 3 - RAWHIDE HAMMER

INSTALLATION

CAUTION: Do not reuse the bolts that held the ring gear to the differential case. The bolts can fracture causing extensive damage.

- (1) Invert the differential case and start two ring gear bolts. This will provide case-to-ring gear bolt alignment.
- (2) Invert the differential case in the vise.

(3) Install new ring gear bolts and alternately tighten to 95–122 N·m (70–90 ft. lbs.) torque (Fig. 52).

(4) Install differential in axle housing and verify gear mesh and contact pattern.

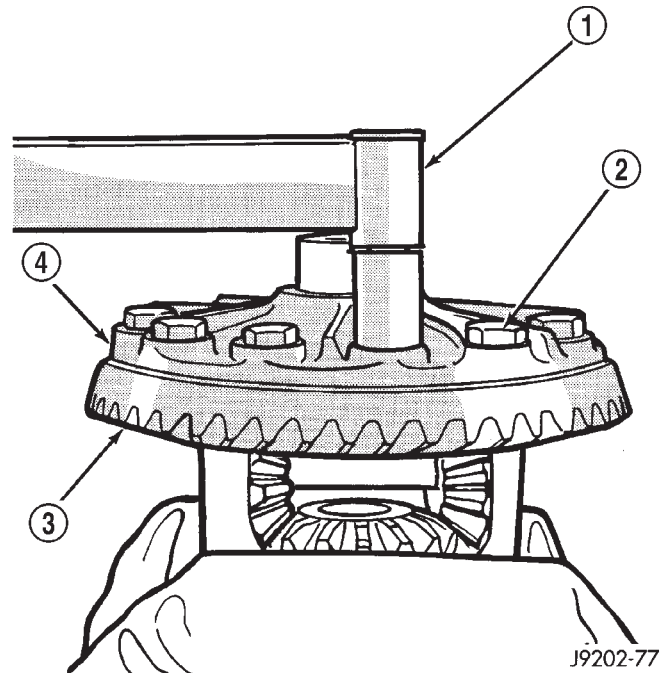

Fig. 52 Ring Gear Bolt Installation

- 1 - TORQUE WRENCH
- 2 - RING GEAR BOLT
- 3 - RING GEAR
- 4 - CASE

DISASSEMBLY AND ASSEMBLY

STANDARD DIFFERENTIAL

DISASSEMBLY

- (1) Remove the ring gear.
- (2) Using a suitable roll pin punch, drive out the roll pin holding pinion gear mate shaft in the differential case (Fig. 53).
- (3) Remove the pinion gear mate shaft from the differential case and the pinion mate gears.
- (4) Rotate differential side gears and remove the pinion mate gears and thrust washers (Fig. 54).
- (5) Remove the differential side gears and thrust washers.

DISASSEMBLY AND ASSEMBLY (Continued)

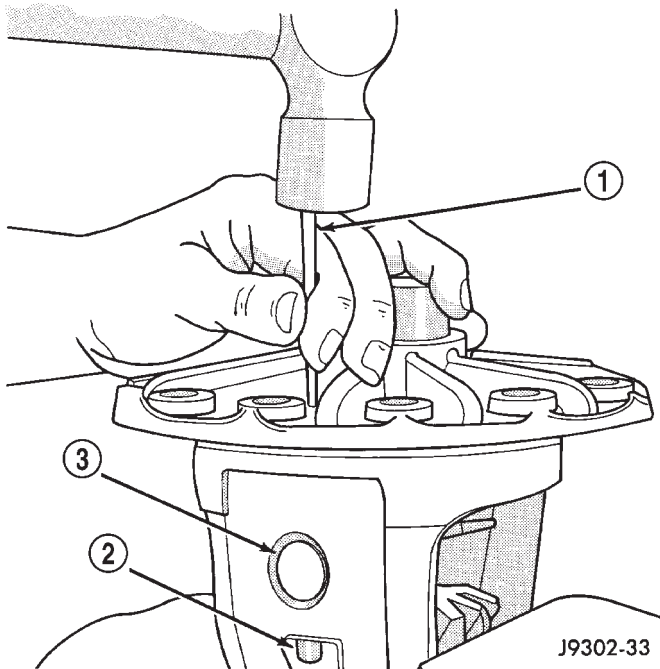

Fig. 53 Mate Shaft Roll Pin Removal

- 1 - DRIFT
- 2 - LOCKPIN
- 3 - MATE SHAFT

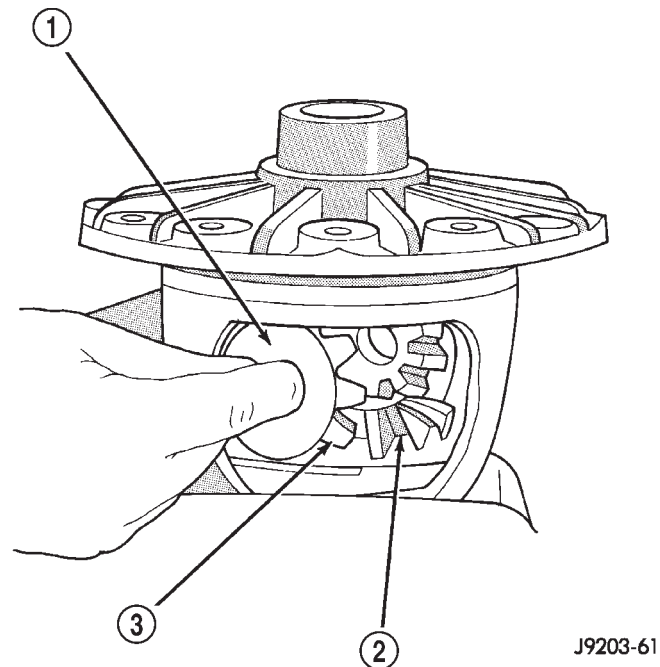

Fig. 54 Pinion Mate Gear Removal

- 1 - THRUST WASHER
- 2 - SIDE GEAR
- 3 - PINION MATE GEAR

ASSEMBLY

- (1) Install the differential side gears and thrust washers.
- (2) Install the pinion mate gears and thrust washers.
- (3) Install the pinion gear mate shaft. Align the roll pin holes in shaft and the differential case.
- (4) Install the roll pin to hold the pinion mate shaft in the differential case (Fig. 55).

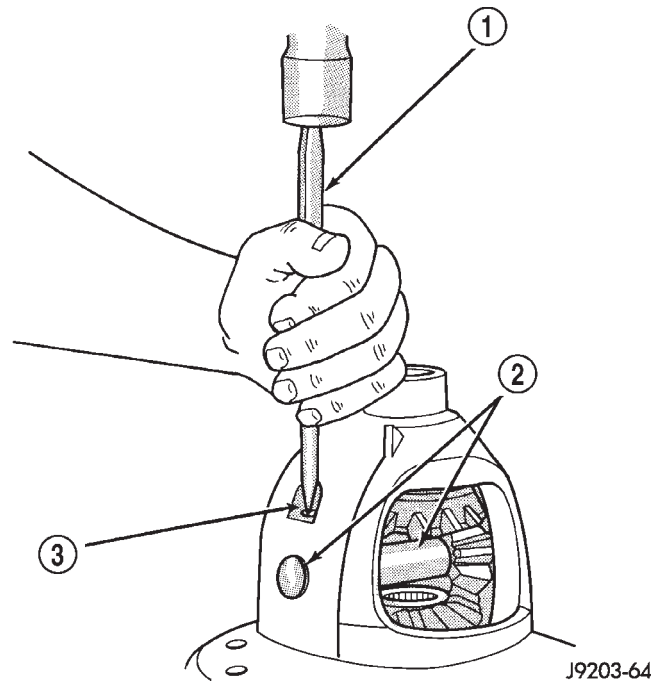

Fig. 55 Mate Shaft Roll Pin Installation

- 1 - PUNCH
- 2 - PINION MATE SHAFT
- 3 - MATE SHAFT LOCKPIN

- (5) Install the ring gear.
- (6) Lubricate all differential components with hypoid gear lubricant.

FINAL ASSEMBLY

(1) Scrape the residual sealant from the housing and cover mating surfaces. Clean the mating surfaces with mineral spirits. Apply a bead of Mopar® Silicone Rubber Sealant, or equivalent, on the housing cover (Fig. 56).

Install the housing cover within 5 minutes after applying the sealant.

(2) Install the cover on the differential with the attaching bolts. Install the identification tag. Tighten the cover bolts to 41 N·m (30 ft. lbs.) torque.

CAUTION: Overfilling the differential can result in lubricant foaming and overheating.

DISASSEMBLY AND ASSEMBLY (Continued)

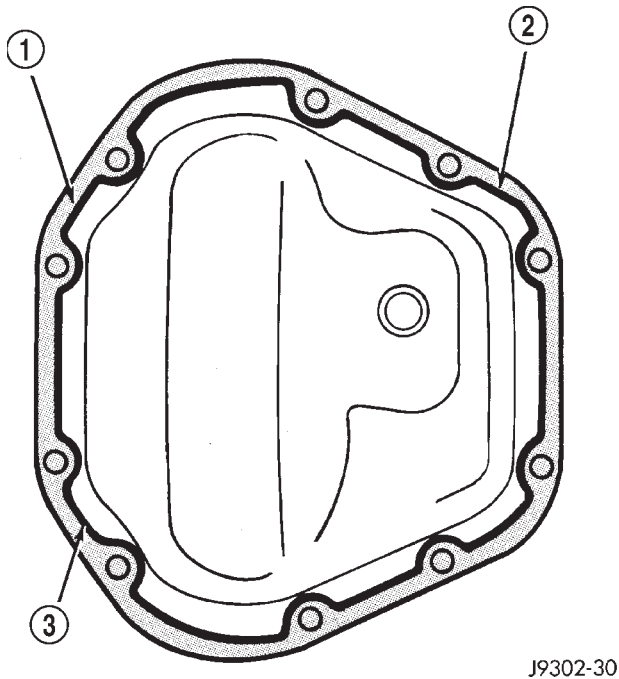

Fig. 56 Typical Housing Cover With Sealant

- 1 - SEALING SURFACE
 2 - CONTOUR OF BEAD
 3 - BEAD THICKNESS 6.35MM (1/4")

(3) Refill the differential housing with gear lubricant. Refer to the Lubricant Specifications section of this group for the gear lubricant requirements.

(4) Install the fill hole plug.

CLEANING AND INSPECTION

CARDAN U-JOINT

Clean all the U-joint yoke bores with cleaning solvent and a wire brush. Ensure that all the rust and foreign matter are removed from the bores.

Inspect the yokes for distortion, cracks and worn bearing cap bores.

Replace the complete U-joint if any of the components are defective.

AXLE COMPONENTS

Wash differential components with cleaning solvent and dry with compressed air. **Do not steam clean the differential components.**

Wash bearings with solvent and towel dry, or dry with compressed air. **DO NOT** spin bearings with compressed air. **Cup and bearing must be replaced as matched sets only.**

Clean axle shaft tubes and oil channels in housing. Inspect for;

- Smooth appearance with no broken/dented surfaces on the bearing rollers or the roller contact surfaces.
- Bearing cups must not be distorted or cracked.
- Machined surfaces should be smooth and without any raised edges.
- Raised metal on shoulders of cup bores should be removed with a hand stone.
- Wear and damage to pinion gear mate shaft, pinion gears, side gears and thrust washers. Replace as a matched set only.
- Ring and pinion gear for worn and chipped teeth.
- Ring gear for damaged bolt threads. Replaced as a matched set only.
- Pinion yoke for cracks, worn splines, pitted areas, and a rough/corroded seal contact surface. Repair or replace as necessary.
- Preload shims for damage and distortion. Install new shims, if necessary.

ADJUSTMENTS

PINION GEAR DEPTH

GENERAL INFORMATION

Ring and pinion gears are supplied as matched sets only. The identifying numbers for the ring and pinion gear are etched into the face of each gear (Fig. 57). A plus (+) number, minus (-) number or zero (0) is etched into the face of the pinion gear. This number is the amount (in thousandths of an inch) the depth varies from the standard depth setting of a pinion etched with a (0). The standard setting from the center line of the ring gear to the back face of the pinion is 92.08 mm (3.625 in.). The standard depth provides the best gear tooth contact pattern. Refer to Backlash and Contact Pattern Analysis paragraph in this section for additional information.

Compensation for pinion depth variance is achieved with a select oil slinger/depth shim. The oil slinger/depth shim is placed between the rear pinion bearing cone and the pinion gear head (Fig. 58).

ADJUSTMENTS (Continued)

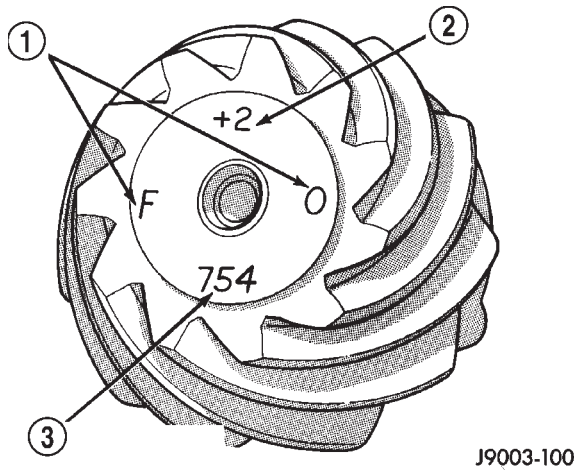

Fig. 57 Pinion Gear ID Numbers

- 1 - PRODUCTION NUMBERS
- 2 - DRIVE PINION GEAR DEPTH VARIANCE
- 3 - GEAR MATCHING NUMBER (SAME AS RING GEAR NUMBER)

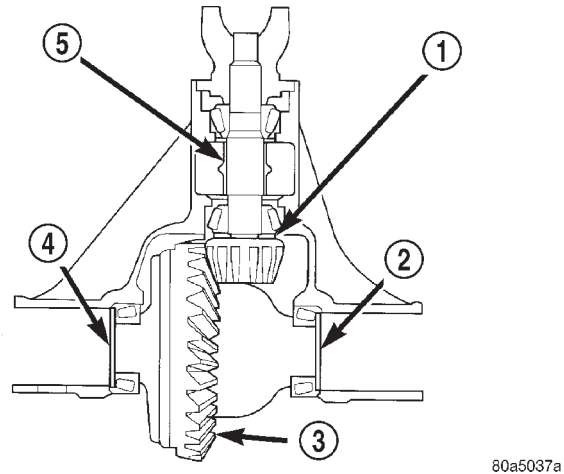

Fig. 58 Shim Locations

- 1 - PINION GEAR DEPTH SHIM
- 2 - DIFFERENTIAL BEARING SHIM-PINION GEAR SIDE
- 3 - RING GEAR
- 4 - DIFFERENTIAL BEARING SHIM-RING GEAR SIDE
- 5 - COLLAPSIBLE SPACER

If a new gear set is being installed, note the depth variance etched into both the original and replacement pinion gear. Add or subtract the thickness of the original depth shims to compensate for the difference in the depth variances. Refer to the Depth Variance chart.

Note where Old and New Pinion Marking columns intersect. Intersecting figure represents plus or minus the amount needed.

Note the etched number on the face of the drive pinion gear (-1, -2, 0, +1, +2, etc.). The numbers represent thousands of an inch deviation from the standard. If the number is negative, add that value to the required thickness of the depth shims. If the number is positive, subtract that value from the thickness of the depth shim. If the number is 0 no change is necessary.

PINION DEPTH MEASUREMENT AND ADJUSTMENT

Measurements are taken with pinion bearings and bearing cups installed in the axle housing. Take measurements with Pinion Gauge Set 6774 and Dial Indicator C-3339 (Fig. 59).

(1) Assemble Pinion Height Block 6739, Pinion Block 6733, and rear pinion bearing onto Screw 6741 (Fig. 59).

(2) Insert assembled height gauge components, rear bearing and screw into axle housing through pinion bearing cups (Fig. 60).

(3) Install front pinion bearing cone and Cone-nut 6740 hand tight (Fig. 59).

(4) Place Arbor Disc 6732 on Arbor D-115-3 in position in axle housing side bearing cradles (Fig. 61). Install differential bearing caps on Arbor Discs and tighten cap bolts to 41 N·m (30 ft. lbs.).

PINION GEAR DEPTH VARIANCE

Original Pinion Gear Depth Variance	Replacement Pinion Gear Depth Variance								
	-4	-3	-2	-1	0	+1	+2	+3	+4
+4	+0.008	+0.007	+0.006	+0.005	+0.004	+0.003	+0.002	+0.001	0
+3	+0.007	+0.006	+0.005	+0.004	+0.003	+0.002	+0.001	0	-0.001
+2	+0.006	+0.005	+0.004	+0.003	+0.002	+0.001	0	-0.001	-0.002
+1	+0.005	+0.004	+0.003	+0.002	+0.001	0	-0.001	-0.002	-0.003
0	+0.004	+0.003	+0.002	+0.001	0	-0.001	-0.002	-0.003	-0.004
-1	+0.003	+0.002	+0.001	0	-0.001	-0.002	-0.003	-0.004	-0.005
-2	+0.002	+0.001	0	-0.001	-0.002	-0.003	-0.004	-0.005	-0.006
-3	+0.001	0	-0.001	-0.002	-0.003	-0.004	-0.005	-0.006	-0.007
-4	0	-0.001	-0.002	-0.003	-0.004	-0.005	-0.006	-0.007	-0.008

ADJUSTMENTS (Continued)

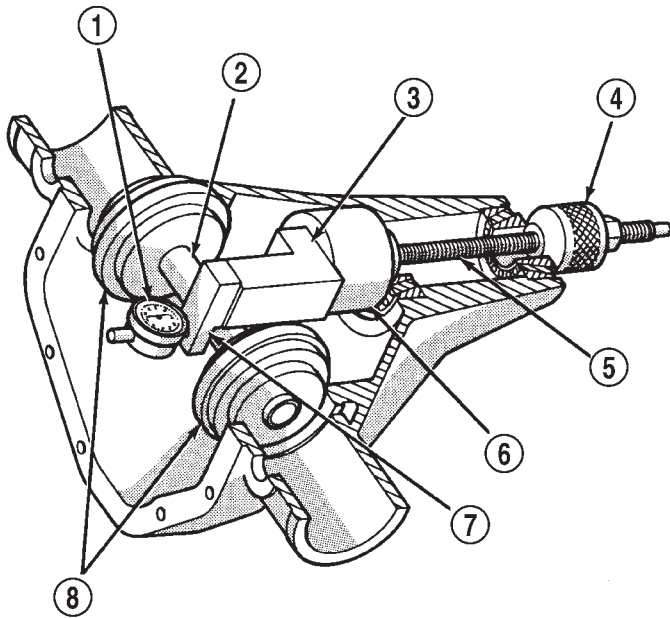

J9403-45

Fig. 59 Pinion Gear Depth Gauge Tools—Typical

- 1 - DIAL INDICATOR
- 2 - ARBOR
- 3 - PINION HEIGHT BLOCK
- 4 - CONE
- 5 - SCREW
- 6 - PINION BLOCK
- 7 - SCOOTER BLOCK
- 8 - ARBOR DISC

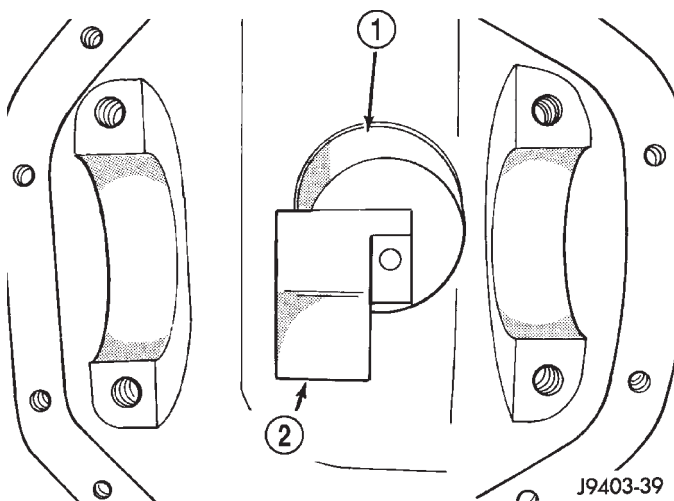

J9403-39

Fig. 60 Pinion Height Block—Typical

- 1 - PINION BLOCK
- 2 - PINION HEIGHT BLOCK

NOTE: Arbor Discs 6732 has different step diameters to fit other axles. Choose proper step for axle being serviced.

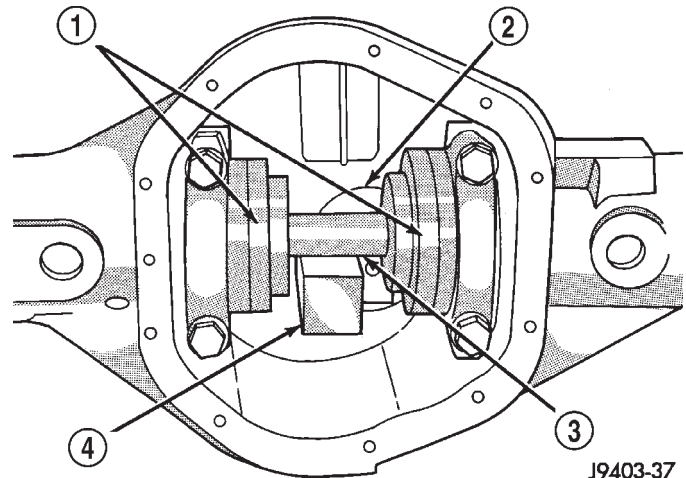

J9403-37

Fig. 61 Gauge Tools In Housing—Typical

- 1 - ARBOR DISC
- 2 - PINION BLOCK
- 3 - ARBOR
- 4 - PINION HEIGHT BLOCK

(5) Assemble Dial Indicator C-3339 into Scooter Block D-115-2 and secure set screw.

(6) Place Scooter Block/Dial Indicator in position in axle housing so dial probe and scooter block are flush against the rearward surface of the pinion height block (Fig. 59). Hold scooter block in place and zero the dial indicator face to the pointer. Tighten dial indicator face lock screw.

(7) With scooter block still in position against the pinion height block, slowly slide the dial indicator probe over the edge of the pinion height block.

(8) Slide the dial indicator probe across the gap between the pinion height block and the arbor bar with the scooter block against the pinion height block (Fig. 62). When the dial probe contacts the arbor bar, the dial pointer will turn clockwise. Bring dial pointer back to zero against the arbor bar, do not turn dial face. Continue moving the dial probe to the crest of the arbor bar and record the highest reading. If the dial indicator can not achieve the zero reading, the rear bearing cup or the pinion depth gauge set is not installed correctly.

(9) Select a shim equal to the dial indicator reading plus the drive pinion gear depth variance number etched in the face of the pinion gear (Fig. 57). For example, if the depth variance is -2 , add $+0.002$ in. to the dial indicator reading.

DIFFERENTIAL BEARING PRELOAD AND GEAR BACKLASH

INTRODUCTION

Differential side bearing preload and gear backlash is achieved by selective shims positioned between the

ADJUSTMENTS (Continued)

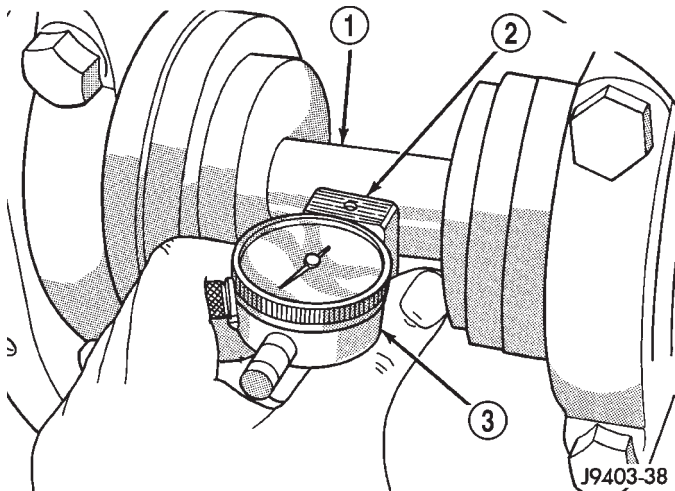
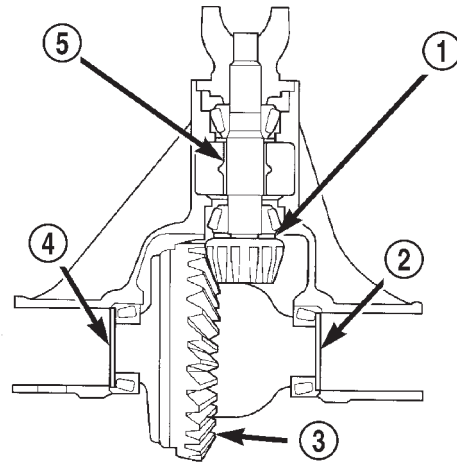

Fig. 62 Pinion Gear Depth Measurement—Typical

- 1 - ARBOR
- 2 - SCOOTER BLOCK
- 3 - DIAL INDICATOR



80a5037a

Fig. 63 Axle Adjustment Shim Locations

- 1 - PINION GEAR DEPTH SHIM
- 2 - DIFFERENTIAL BEARING SHIM-PINION GEAR SIDE
- 3 - RING GEAR
- 4 - DIFFERENTIAL BEARING SHIM-RING GEAR SIDE
- 5 - COLLAPSIBLE SPACER

differential side bearing cups and the axle housing. The proper shim thickness can be determined using slip-fit dummy bearings D-348 in place of the differential side bearings and a dial indicator C-3339. Before proceeding with the differential bearing preload and gear backlash measurements, measure the pinion gear depth and prepare the pinion gear for installation. Establishing proper pinion gear depth is essential to establishing gear backlash and tooth contact patterns. After the overall shim thickness to take up differential side play is measured, the pinion gear is installed, and the gear backlash shim thickness is measured. The overall shim thickness is the total of the dial indicator reading, starting point shim thickness, and the preload specification added together. The gear backlash measurement determines the thickness of the shim used on the ring gear side of the differential case. Subtract the gear backlash shim thickness from the total overall shim thickness and select that amount for the pinion gear side of the differential (Fig. 63). Differential shim measurements are performed with axle spreader W-129-B removed.

SHIM SELECTION

NOTE: It is difficult to salvage the differential side bearings during the removal procedure. Install replacement bearings if necessary.

- (1) Remove differential side bearings from differential case.
- (2) Install ring gear on differential case and tighten bolts to specification.
- (3) Install dummy side bearings D-348 on differential case.

- (4) Install differential case in axle housing.
- (5) Measure and record the thickness of Dummy Shims 8107 (0.118 in. (3.0 mm)) starting point shims for future reference. Insert Dummy Shims 8107 starting point shims between the dummy bearings and the axle housing (Fig. 64).

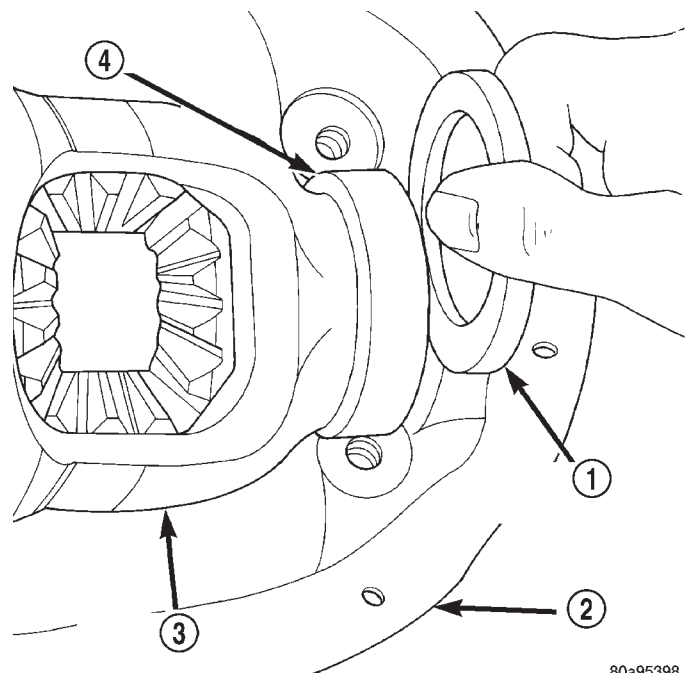

80a95398

Fig. 64 Insert Starting Point Shims

- 1 - SPECIAL TOOL 8107
- 2 - AXLE HOUSING
- 3 - DIFFERENTIAL CASE
- 4 - SPECIAL TOOL D-348

ADJUSTMENTS (Continued)

(6) Install the marked bearing caps in their correct positions. Install and snug the bolts (Fig. 65).

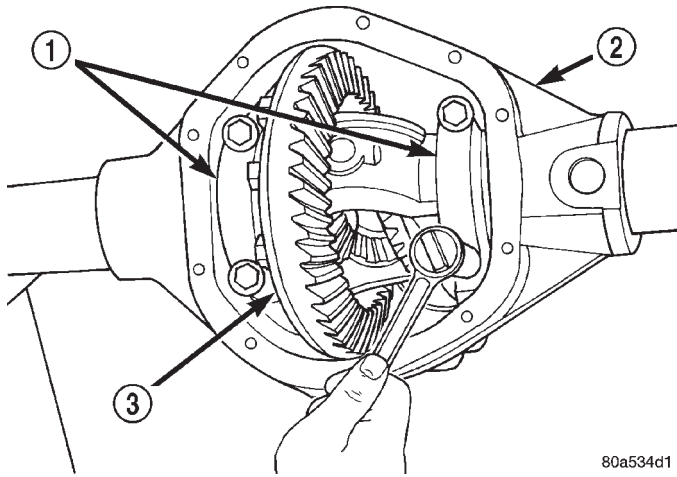

80a534d1

Fig. 65 Tighten Bolts Holding Bearing Caps

- 1 - BEARING CAP
- 2 - AXLE HOUSING
- 3 - DIFFERENTIAL CASE

(7) Using a dead-blow type mallet, seat the differential dummy bearings to each side of the axle housing (Fig. 66) and (Fig. 67).

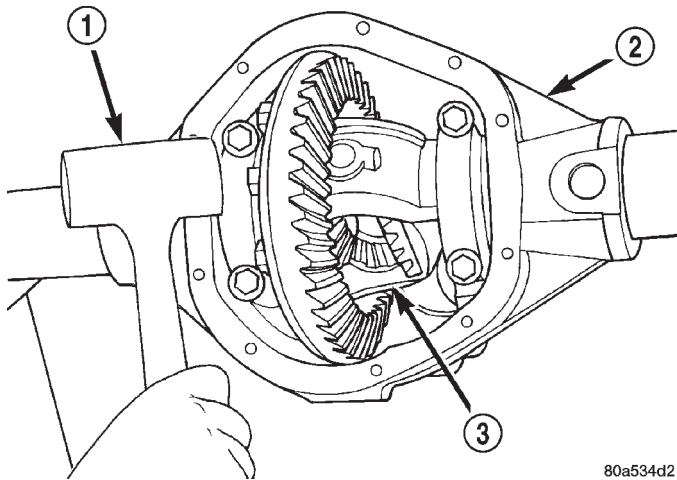

80a534d2

Fig. 66 Seat Pinion Gear Side Differential Dummy Side Bearing

- 1 - MALLET
- 2 - AXLE HOUSING
- 3 - DIFFERENTIAL CASE

(8) Thread guide stud C-3288-B into rear cover bolt hole below ring gear (Fig. 68).

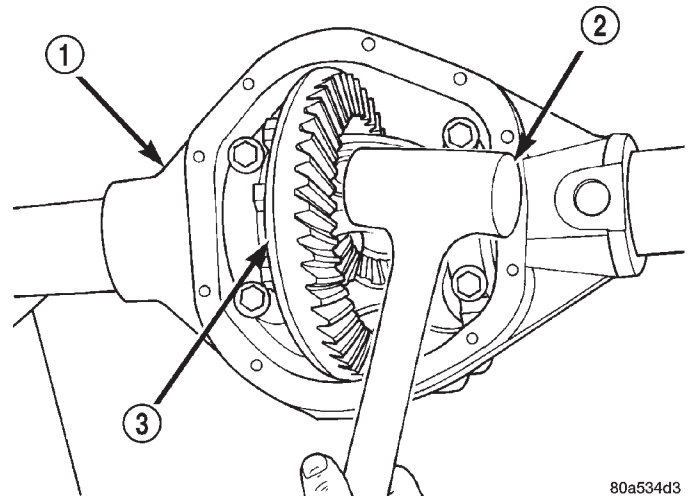

80a534d3

Fig. 67 Seat Ring Gear Side Differential Dummy Side Bearing

- 1 - AXLE HOUSING
- 2 - MALLET
- 3 - DIFFERENTIAL CASE

(9) Attach a dial indicator C-3339 to guide stud. Position the dial indicator plunger on a flat surface between the ring gear bolt heads (Fig. 68).

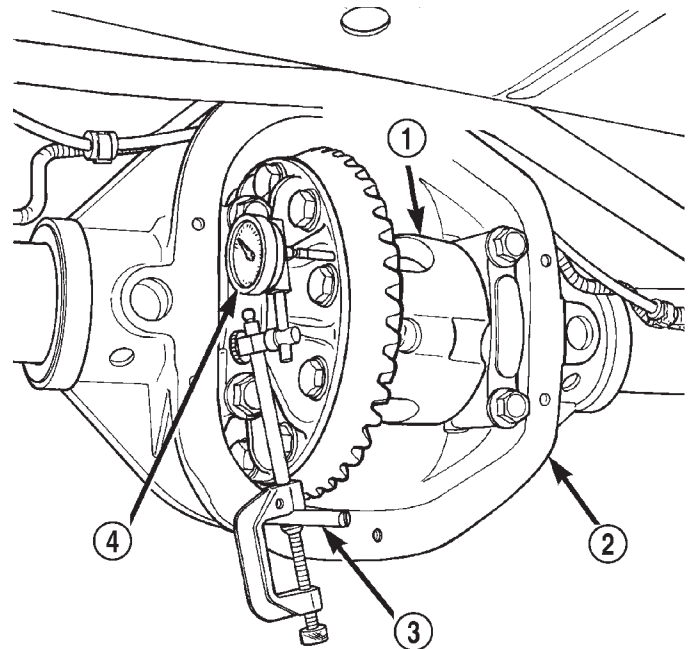

80a7e2cf

Fig. 68 Differential Side play Measurement

- 1 - DIFFERENTIAL CASE
- 2 - AXLE HOUSING
- 3 - SPECIAL TOOL C-3288-B
- 4 - SPECIAL TOOL C-3339

ADJUSTMENTS (Continued)

- (10) Push and hold differential case to pinion gear side of axle housing (Fig. 69).
- (11) Zero dial indicator face to pointer (Fig. 69).

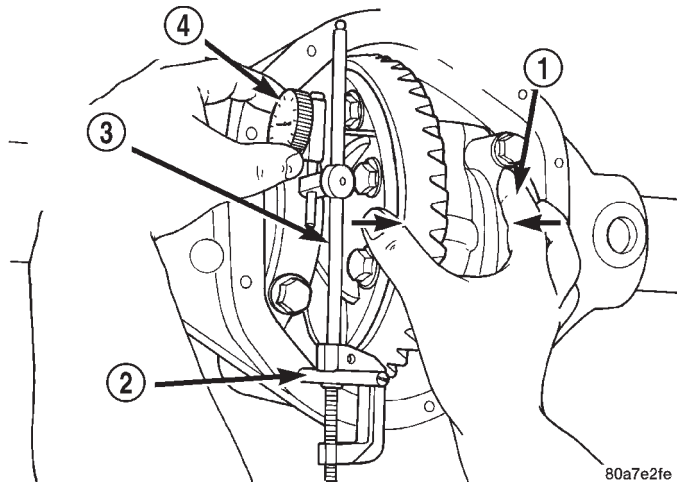

Fig. 69 Hold Differential Case and Zero Dial Indicator

- 1 - FORCE DIFFERENTIAL CASE TO PINION GEAR SIDE
- 2 - SPECIAL TOOL C-3288-B
- 3 - SPECIAL TOOL C-3339
- 4 - ZERO DIAL INDICATOR FACE

- (12) Push and hold differential case to ring gear side of the axle housing (Fig. 70).
- (13) Record dial indicator reading (Fig. 70).
- (14) Add the dial indicator reading to the starting point shim thickness to determine the total shim thickness necessary to achieve zero differential end-play.

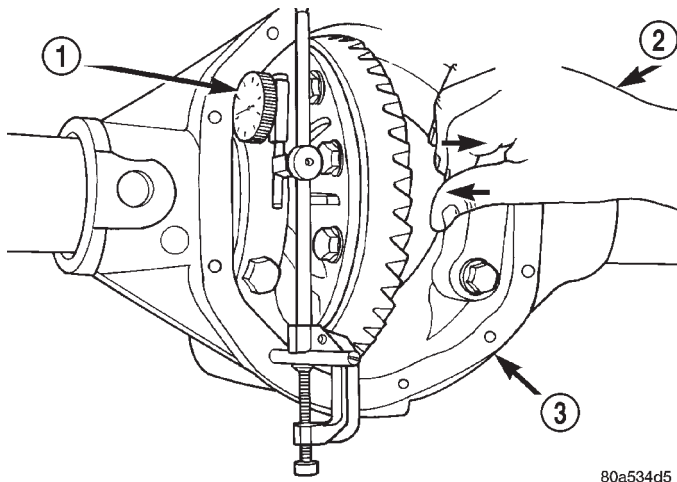

Fig. 70 Hold Differential Case and Read Dial Indicator

- 1 - READ DIAL INDICATOR
- 2 - FORCE DIFFERENTIAL CASE TO RING GEAR SIDE
- 3 - AXLE HOUSING

- (15) Add 0.006 in. (0.152 mm) to the zero end play total. This new total represents the thickness of shims to compress, or preload the new bearings when the differential is installed.

(16) Rotate dial indicator out of the way on the guide stud.

(17) Remove differential case, dummy shims, and dummy bearings from axle housing.

(18) Install the pinion gear in axle housing. Install the pinion yoke, or flange, and establish the correct pinion rotating torque. Record the value for use in setting the differential total torque to rotate.

(19) Install differential case and dummy bearings D-348 in axle housing with a single Dummy Shim 8107 installed between the ring gear side dummy bearing and the axle housing. Install bearing caps and tighten bolts snug.

(20) Seat ring gear side dummy bearing (Fig. 67).

(21) Position the dial indicator plunger on a flat surface between the ring gear bolt heads. (Fig. 68).

(22) Push and hold differential case toward pinion gear (Fig. 71).

(23) Zero dial indicator face to pointer (Fig. 71).

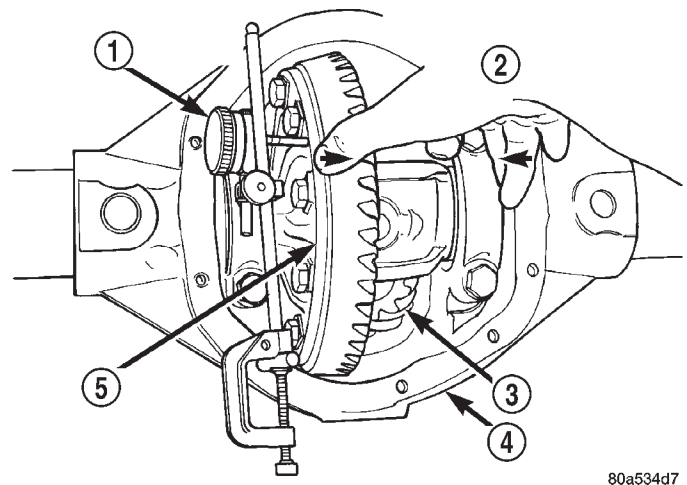

Fig. 71 Hold Differential Case and Zero Dial Indicator

- 1 - ZERO DIAL INDICATOR FACE
- 2 - FORCE DIFFERENTIAL CASE TO PINION GEAR SIDE
- 3 - PINION GEAR
- 4 - AXLE HOUSING
- 5 - DIFFERENTIAL CASE

ADJUSTMENTS (Continued)

(24) Push and hold differential case to ring gear side of the axle housing (Fig. 72).

(25) Record dial indicator reading (Fig. 72). Add the starting point shim thickness to the dial indicator reading to obtain the total shim thickness necessary to achieve zero backlash.

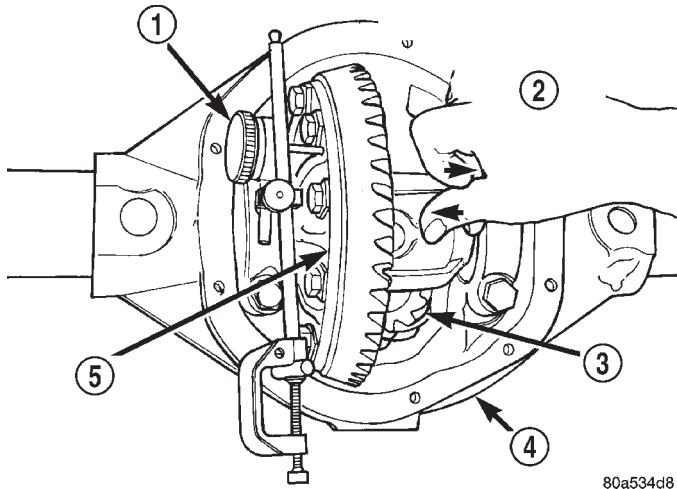

80a534d8

Fig. 72 Hold Differential Case and Read Dial Indicator

- 1 - READ DIAL INDICATOR
- 2 - FORCE DIFFERENTIAL CASE TO RING GEAR SIDE
- 3 - PINION GEAR
- 4 - AXLE HOUSING
- 5 - DIFFERENTIAL CASE

(26) Subtract 0.003 in. (0.076 mm) from the dial indicator reading to compensate for backlash between ring and pinion gears. This total is the thickness shim required to achieve proper backlash.

(27) Subtract the backlash shim thickness from the total preload shim thickness. The remainder is the shim thickness required on the pinion side of the axle housing.

(28) Rotate dial indicator out of the way on guide stud.

(29) Remove differential case and dummy bearings from axle housing.

(30) Install side bearings and cups on differential case.

(31) Install spreader W-129-B, utilizing some items from Adapter Set 6987, on axle housing and spread axle opening enough to receive differential case.

(32) Place the required differential bearing preload shims in the axle housing against the axle tubes.

(33) Install differential case in axle housing.

(34) Remove spreader from axle housing.

(35) Rotate the differential case several times to seat the side bearings.

(36) Position the indicator plunger against a ring gear tooth (Fig. 73).

(37) Push and hold ring gear upward while not allowing the pinion gear to rotate.

(38) Zero dial indicator face to pointer.

(39) Push and hold ring gear downward while not allowing the pinion gear to rotate. Dial indicator reading should be between 0.12 mm (0.005 in.) and 0.20 mm (0.008 in.). If backlash is not within specifications transfer the necessary amount of shim thickness from one side of the axle housing to the other (Fig. 74).

(40) Verify differential case and ring gear runout by measuring ring to pinion gear backlash at eight locations around the ring gear. Readings should not vary more than 0.05 mm (0.002 in.). If readings vary more than specified, the ring gear or the differential case is defective.

After the proper backlash is achieved, perform Gear Contact Pattern Analysis procedure.

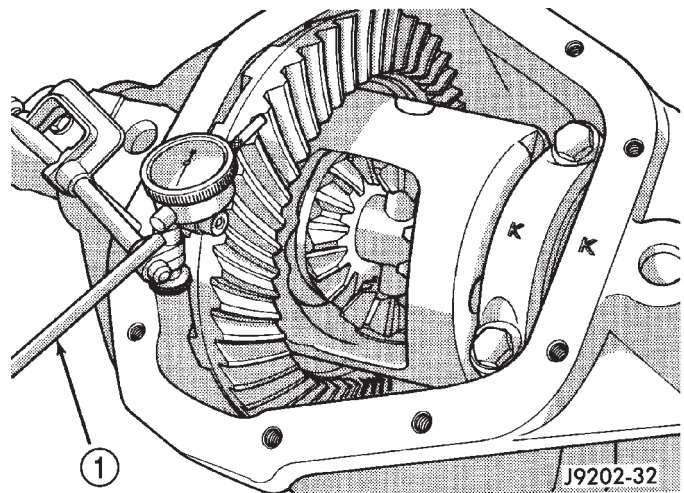

J9202-32

Fig. 73 Ring Gear Backlash Measurement

- 1 - DIAL INDICATOR

DIFFERENTIAL TOTAL TORQUE TO ROTATE

(1) Rotate the pinion a minimum of ten times to seat the differential bearings. Verify that the rotation is smooth and repeatable.

(2) While rotating the pinion at a slow steady rate, measure the differential total torque to rotate. Record the value.

(3) The differential total torque to rotate must be greater than the pinion torque to rotate plus 3 in.lbs. for axles equipped with an standard differential. On axles equipped with a Vari-Lok™ differential, the differential total torque to rotate must be greater than the pinion torque to rotate plus 6 in.lbs..

(4) The differential total torque to rotate must be less than the pinion torque to rotate plus 11 in.lbs. for axles equipped with an standard differential. On axles equipped with a Vari-Lok™ differential, the dif-

ADJUSTMENTS (Continued)

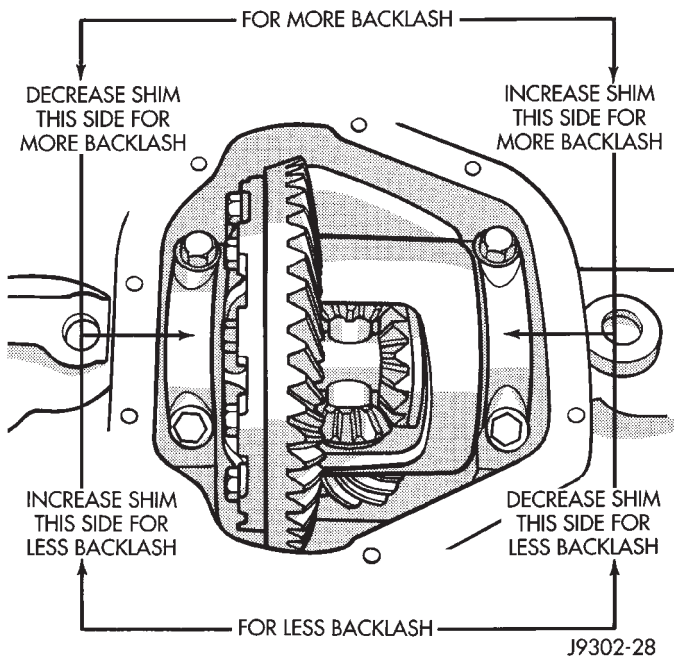

Fig. 74 Backlash Shim Adjustment

differential total torque to rotate must be less than the pinion torque to rotate plus 16 in.lbs..

(5) If the differential total torque to rotate is within these guidelines, assemble the remainder of the axle.

(6) If the differential total torque to rotate is less than the required value, increase the shim thickness on the ring and pinion gear sides of the differential equally.

(7) If the differential total torque to rotate is greater than the required value, decrease the shim thickness on the ring and pinion gear sides of the differential equally.

(8) Remeasure the differential total torque to rotate.

GEAR CONTACT PATTERN ANALYSIS

The ring gear and pinion teeth contact patterns will show if the pinion depth is correct in the axle housing. It will also show if the ring gear backlash has been adjusted correctly. The backlash can be adjusted within specifications to achieve desired tooth contact patterns.

(1) Apply a thin coat of hydrated ferric oxide, or equivalent, to the drive and coast side of the ring gear teeth.

(2) Wrap, twist, and hold a shop towel around the pinion yoke to increase the turning resistance of the pinion. This will provide a more distinct contact pattern.

(3) Using a boxed end wrench on a ring gear bolt, rotate the differential case one complete revolution in both directions while a load is being applied from shop towel.

The areas on the ring gear teeth with the greatest degree of contact against the pinion teeth will squeegee the compound to the areas with the least amount of contact. Note and compare patterns on the ring gear teeth to Gear Tooth Contact Patterns chart (Fig. 75) and adjust pinion depth and gear backlash as necessary.

ADJUSTMENTS (Continued)

<p>DRIVE SIDE OF RING GEAR TEETH</p> <p>HEEL TOE</p> 	<p>COAST SIDE OF RING GEAR TEETH</p> <p>TOE HEEL</p> 	<p>DESIRABLE CONTACT PATTERN. PATTERN SHOULD BE CENTERED ON THE DRIVE SIDE OF TOOTH. PATTERN SHOULD BE CENTERED ON THE COAST SIDE OF TOOTH, BUT MAY BE SLIGHTLY TOWARD THE TOE. THERE SHOULD ALWAYS BE SOME CLEARANCE BETWEEN CONTACT PATTERN AND TOP OF THE TOOTH.</p>
		<p>RING GEAR BACKLASH CORRECT. THINNER PINION GEAR DEPTH SHIM REQUIRED.</p>
		<p>RING GEAR BACKLASH CORRECT. THICKER PINION GEAR DEPTH SHIM REQUIRED.</p>
		<p>PINION GEAR DEPTH SHIM CORRECT. DECREASE RING GEAR BACKLASH.</p>
		<p>PINION GEAR DEPTH SHIM CORRECT. INCREASE RING GEAR BACKLASH.</p>

Fig. 75 Gear Tooth Contact Patterns

SPECIFICATIONS

186 FBI AXLE

Axle Type Hypoid
 Lubricant SAE Thermally Stable 80W-90
 Lube Capacity-w/o Vari-lok™ 1.18 L (2.5 pts.)
 Lube Capacity-w/ Vari-lok™ . 1.19 L (2.51 pts.) total
 Friction Modifier-Vari-lok™ only . . 0.07L (0.15 pts.)
 Axle Ratio..... 3.07, 3.55, 3.73, 4.10
 Differential Side Gear Clearance . . . 0.12-0.20 mm
 (0.005-0.008 in.)
 Ring Gear Diameter 18.59 cm (7.33 in.)
 Backlash..... 0-0.15 mm (0.005-0.008 in.)
 Pinion Std. Depth..... 92.1 mm (3.625 in.)
 Pinion Bearing Rotating Torque
 Original Bearings 1-2.25 N·m (10-20 in. lbs.)
 New Bearings 1-2.8 N·m (10-25 in. lbs.)

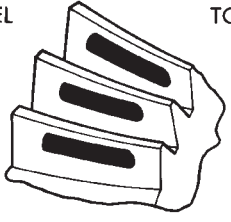
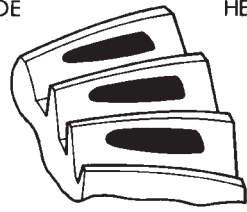
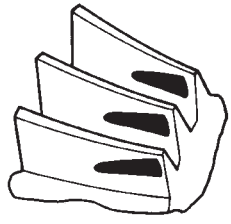
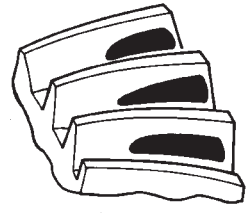
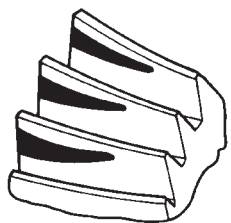
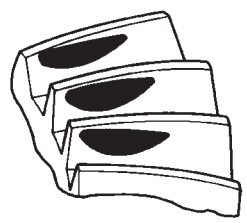
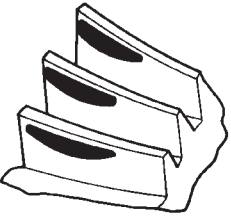
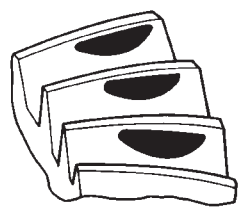
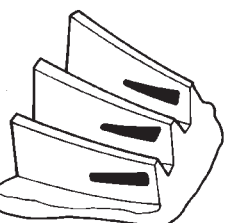
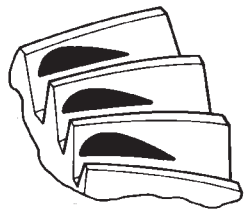
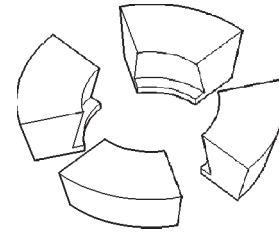

Adapter—8352

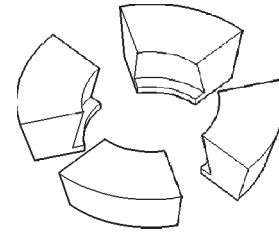

Adapter—C-293-39

186 FBI AXLE

DESCRIPTION	TORQUE
Fill Hole Plug	34 N·m (25 ft. lbs.)
Diff. Cover Bolt	41 N·m (30 ft. lbs.)
Bearing Cap Bolt.....	61 N·m (45 ft. lbs.)
Ring Gear Bolt	95-122 N·m (70-90 ft. lbs.)
Axle Nut	237 N·m (175 ft. lbs.)
Hub Brg. Bolt	102 N·m (75 ft. lbs.)
Lower Ball Stud	108 N·m (80 ft. lbs.)
Upper Ball Stud	101 N·m (75 ft. lbs.)

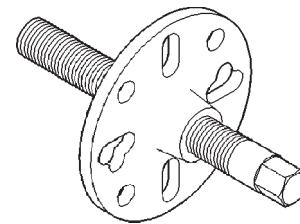

Puller—C-452

SPECIAL TOOLS

186 FBI AXLE

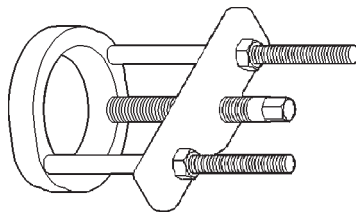

Puller—C-293-PA

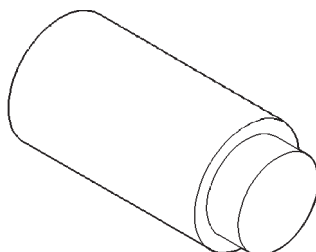

Plug—SP-3289

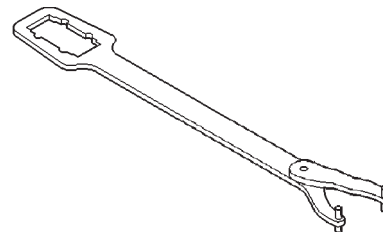

Wrench—C-3281

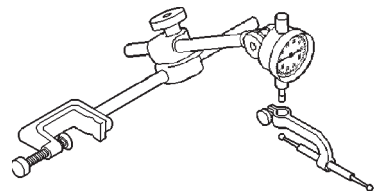

Dial Indicator—C-3339

8011d42b

SPECIAL TOOLS (Continued)

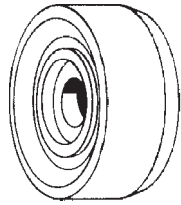

Driver—C-3716-A

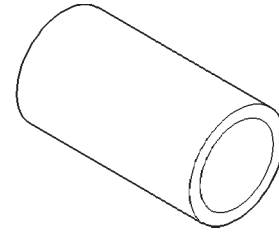

Cup—8109

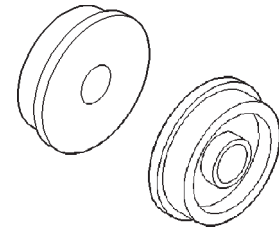

Installer Discs—8110

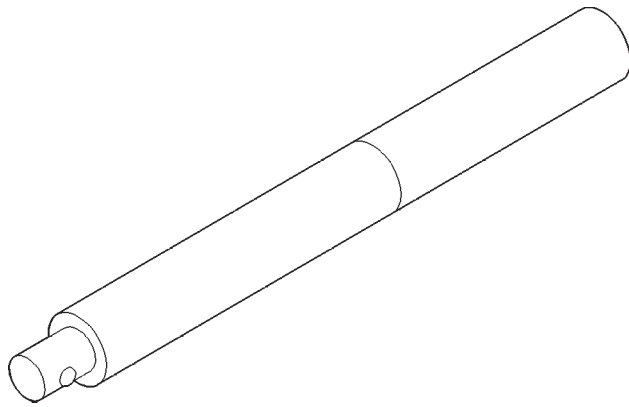

Handle—C-4171

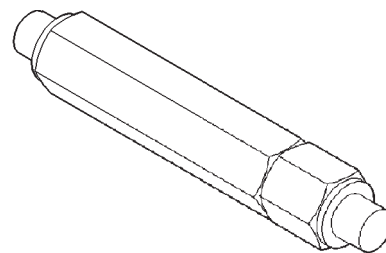

Turnbuckle—6797

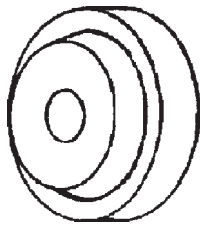

Installer—D-146

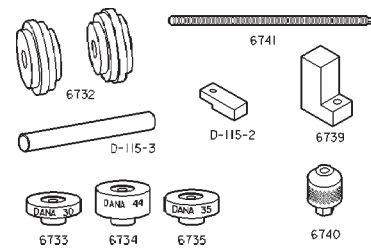

Tool Set, Pinion Depth—6774

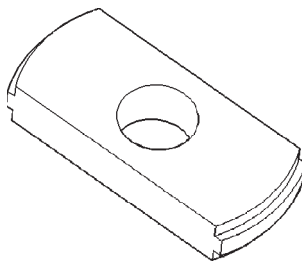

Remover—D-149

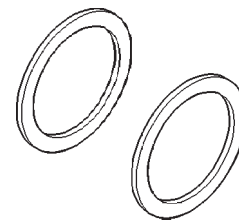

Starting Point Shim—8107

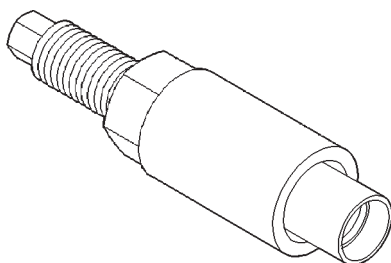

Installer—W-162-D

SPECIAL TOOLS (Continued)

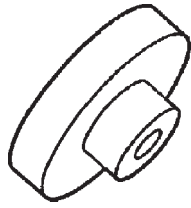

Gauge Block—6733

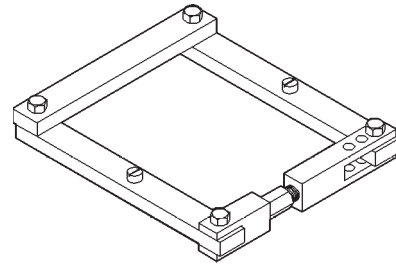

Spreader—W-129-B

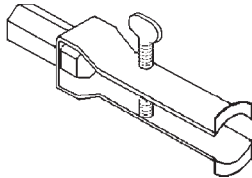

Puller—7794-A

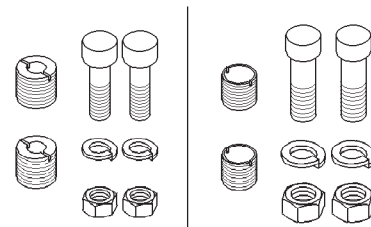

1-1/8 HEX TURNBUCKLE 1-1/4 HEX TURNBUCKLE

Adapter Kit—6987

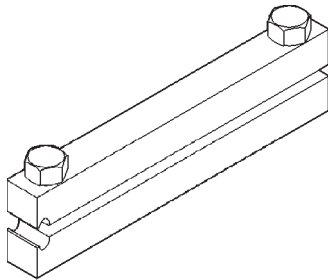

Installer—C-4975-A

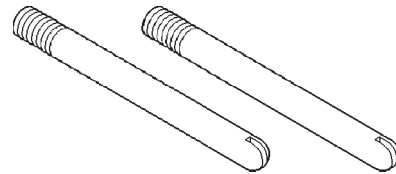

Pilot Stud—C-3288-B

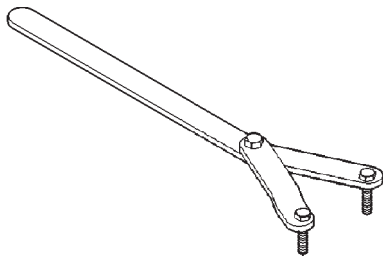

Spanner—6958

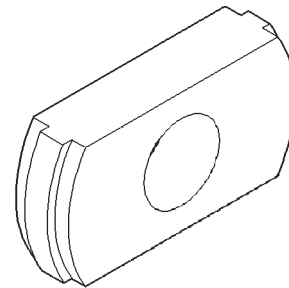

Remover—C-4345

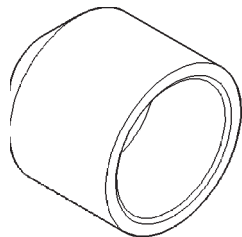

Installer—8108

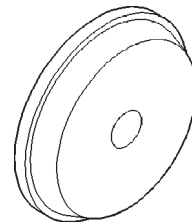

Installer—D-130

SPECIAL TOOLS (Continued)

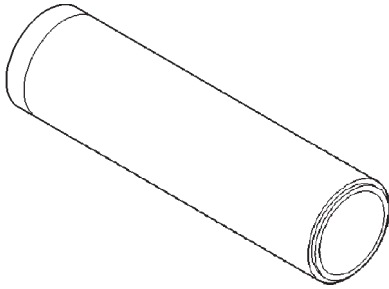

Installer—W-262

198 RBI AXLE

TABLE OF CONTENTS

	page		page
DESCRIPTION AND OPERATION			
198 RBI AXLE	53	DIFFERENTIAL	68
LUBRICANT	54	DIFFERENTIAL SIDE BEARINGS	70
STANDARD DIFFERENTIAL	54	RING GEAR	71
TRAC-LOK™ DIFFERENTIAL	55	PINION GEAR	72
DIAGNOSIS AND TESTING			
GENERAL INFORMATION	55	FINAL ASSEMBLY	77
GEAR NOISE	58	DISASSEMBLY AND ASSEMBLY	
BEARING NOISE	58	STANDARD DIFFERENTIAL	77
LOW SPEED KNOCK	58	TRAC-LOK™ DIFFERENTIAL	78
VIBRATION	58	CLEANING AND INSPECTION	
DRIVELINE SNAP	59	AXLE COMPONENTS	82
TRAC-LOK™ DIFFERENTIAL NOISE	59	TRAC-LOK™	82
TRAC-LOK™ TEST	59	ADJUSTMENTS	
SERVICE PROCEDURES			
LUBRICANT CHANGE	59	PINION GEAR DEPTH	83
REMOVAL AND INSTALLATION			
REAR AXLE	60	DIFFERENTIAL BEARING PRELOAD AND GEAR BACKLASH	85
PINION SHAFT SEAL	61	GEAR CONTACT PATTERN ANALYSIS	89
COLLAPSIBLE SPACER	63	SPECIFICATIONS	
AXLE SHAFT	66	198 RBI AXLE	91
AXLE SHAFT SEAL AND BEARING	66	198 RBI AXLE	91
		SPECIAL TOOLS	
		198 RBI AXLE	91

DESCRIPTION AND OPERATION

198 RBI AXLE

DESCRIPTION

The 198 Rear Beam-design Iron (RBI) axle housing has an iron center casting (differential housing) with axle shaft tubes extending from either side. The tubes are pressed into and welded to the differential housing to form a one-piece axle housing.

The integral type, hypoid gear design, housing has the centerline of the pinion set below the centerline of the ring gear.

The axle has a vent hose to relieve internal pressure caused by lubricant vaporization and internal expansion.

The axles are equipped with semi-floating axle shafts, meaning that loads are supported by the axle shaft and bearings. The axle shafts are retained by bearing retainer plates on the axles which are bolted to flanges at the outboard end of the axle tubes.

The cover provides a means for servicing the differential without removing the axle.

For vehicles equipped with ABS brakes, the axles have a tone ring pressed onto the axle shaft. Use

care when removing axle shafts to ensure that the tone wheel or the wheel speed sensor are not damaged.

The 198 RBI axle has the assembly part number and gear ratio listed on a tag. The tag is attached to the differential housing by a cover bolt. Build date identification codes are stamped on the cover side of an axle shaft tube.

The differential case is a one-piece design. The differential pinion mate shaft is retained with a threaded pin. Differential bearing preload and ring gear backlash is adjusted by the use of selective spacer shims. Pinion bearing preload is set and maintained by the use of a collapsible spacer (Fig. 1).

Axles equipped with a Trac-Lok™ differential are optional. A Trac-Lok differential has a one-piece differential case, and the same internal components as a standard differential, plus two clutch disc packs.

OPERATION

The axle receives power from the transmission/transfer case through the rear propeller shaft. The rear propeller shaft is connected to the pinion gear which rotates the differential through the gear mesh with the ring gear bolted to the differential case. The engine power is transmitted to the axle shafts

DESCRIPTION AND OPERATION (Continued)

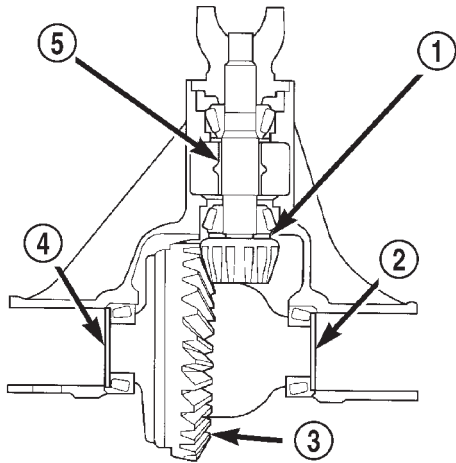

80a5037a

Fig. 1 Shim Locations

- 1 - PINION GEAR DEPTH SHIM
- 2 - DIFFERENTIAL BEARING SHIM-PINION GEAR SIDE
- 3 - RING GEAR
- 4 - DIFFERENTIAL BEARING SHIM-RING GEAR SIDE
- 5 - COLLAPSIBLE SPACER

through the pinion mate and side gears. The side gears are splined to the axle shafts.

LUBRICANT**DESCRIPTION**

A multi-purpose, hypoid gear lubricant which conforms to the following specifications should be used. Mopar® Hypoid Gear Lubricant conforms to all of these specifications.

- The lubricant should have MIL-L-2105C and API GL 5 quality specifications.
- Lubricant is a thermally stable SAE 80W-90 gear lubricant.
- Lubricant for axles intended for heavy-duty or trailer tow use is SAE 75W-140 SYNTHETIC gear lubricant.

Trac-lok™ differentials require the addition of 0.11L (0.25 pts.) of friction modifier to the axle lubricant. The 198 RBI axle lubricant capacity for axles equipped with a standard or Trac-lok™ differential is 1.66L (3.50 pts.) total, including the friction modifier if necessary.

CAUTION: If axle is submerged in water, lubricant must be replaced immediately to avoid possible premature axle failure.

STANDARD DIFFERENTIAL**DESCRIPTION**

The differential gear system divides the torque between the axle shafts. It allows the axle shafts to rotate at different speeds when turning corners.

Each differential side gear is splined to an axle shaft. The pinion gears are mounted on a pinion mate shaft and are free to rotate on the shaft. The pinion gear is fitted in a bore in the differential case and is positioned at a right angle to the axle shafts.

OPERATION

In operation, power flow occurs as follows:

- The pinion gear rotates the ring gear
- The ring gear (bolted to the differential case) rotates the case
- The differential pinion gears (mounted on the pinion mate shaft in the case) rotate the side gears
- The side gears (splined to the axle shafts) rotate the shafts

During straight-ahead driving, the differential pinion gears do not rotate on the pinion mate shaft. This occurs because input torque applied to the gears is divided and distributed equally between the two side gears. As a result, the pinion gears revolve with the pinion mate shaft but do not rotate around it (Fig. 2).

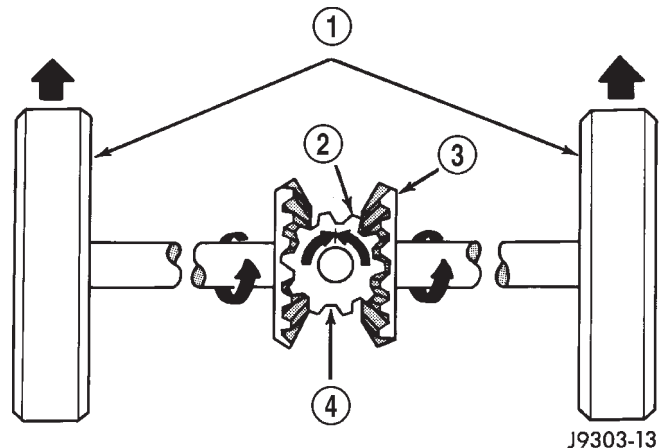

J9303-13

Fig. 2 Differential Operation—Straight Ahead Driving

- 1 - IN STRAIGHT AHEAD DRIVING EACH WHEEL ROTATES AT 100% OF CASE SPEED
- 2 - PINION GEAR
- 3 - SIDE GEAR
- 4 - PINION GEARS ROTATE WITH CASE

When turning corners, the outside wheel must travel a greater distance than the inside wheel to complete a turn. The difference must be compensated for to prevent the tires from scuffing and skidding through turns. To accomplish this, the differential allows the axle shafts to turn at unequal speeds (Fig. 3). In this instance, the input torque applied to the

DESCRIPTION AND OPERATION (Continued)

pinion gears is not divided equally. The pinion gears now rotate around the pinion mate shaft in opposite directions. This allows the side gear and axle shaft attached to the outside wheel to rotate at a faster speed.

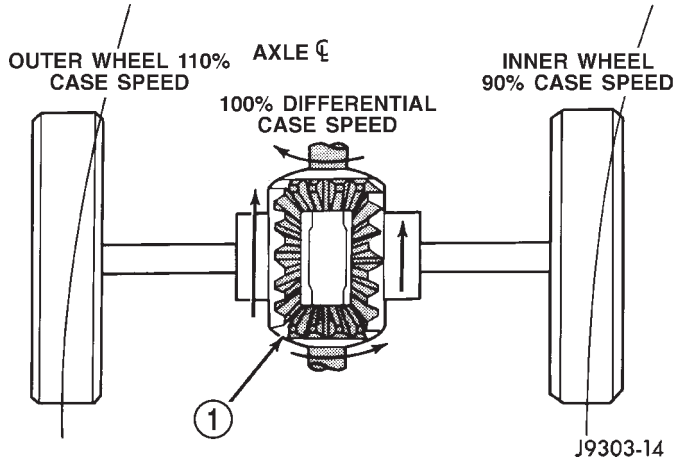

Fig. 3 Differential Operation—On Turns

1 - PINION GEARS ROTATE ON PINION SHAFT

TRAC-LOK™ DIFFERENTIAL

DESCRIPTION

In a standard differential, if one wheel spins, the opposite wheel will generate only as much torque as the spinning wheel.

In the Trac-lok™ differential, part of the ring gear torque is transmitted through clutch packs which contain multiple discs. The clutches will have radial grooves on the plates, and concentric grooves on the discs or bonded fiber material that is smooth in appearance.

OPERATION

In operation, the Trac-lok™ clutches are engaged by two concurrent forces. The first being the preload force exerted through Belleville spring washers within the clutch packs. The second is the separating forces generated by the side gears as torque is applied through the ring gear (Fig. 4).

The Trac-lok™ design provides the differential action needed for turning corners and for driving straight ahead during periods of unequal traction. When one wheel loses traction, the clutch packs transfer additional torque to the wheel having the most traction. Trac-lok™ differentials resist wheel spin on bumpy roads and provide more pulling power when one wheel loses traction. Pulling power is provided continuously until both wheels lose traction. If both wheels slip due to unequal traction, Trac-lok™ operation is normal. In extreme cases of differences

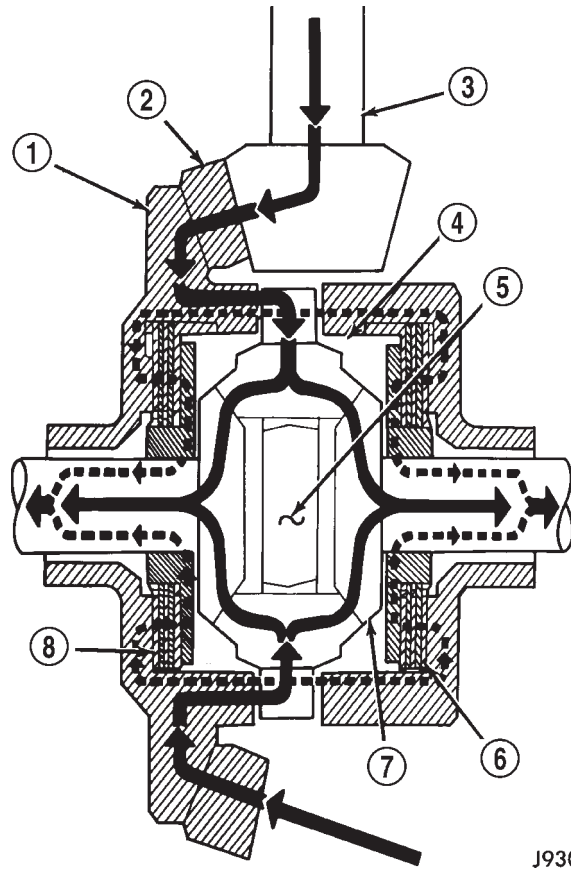

Fig. 4 Trac-lok™ Limited Slip Differential Operation

- 1 - CASE
- 2 - RING GEAR
- 3 - DRIVE PINION
- 4 - PINION GEAR
- 5 - MATE SHAFT
- 6 - CLUTCH PACK
- 7 - SIDE GEAR
- 8 - CLUTCH PACK

of traction, the wheel with the least traction may spin.

DIAGNOSIS AND TESTING

GENERAL INFORMATION

Axle bearing problem conditions are usually caused by:

- Insufficient or incorrect lubricant.
- Foreign matter/water contamination.
- Incorrect bearing preload torque adjustment.
- Incorrect backlash.

Axle gear problem conditions are usually the result of:

- Insufficient lubrication.
- Incorrect or contaminated lubricant.
- Overloading (excessive engine torque) or exceeding vehicle weight capacity.

DIAGNOSIS AND TESTING (Continued)

- Incorrect clearance or backlash adjustment.
- Incorrect lubricant.
- Axle component breakage is most often the result of:
 - Severe overloading.
 - Insufficient lubricant.
 - Improperly tightened components.
 - Differential housing bores not square to each other.

DIAGNOSTIC CHART

Condition	Possible Causes	Correction
Wheel Noise	<ol style="list-style-type: none"> 1. Wheel loose. 2. Faulty, brinelled wheel bearing. 	<ol style="list-style-type: none"> 1. Tighten loose nuts. 2. Replace bearing.
Axle Shaft Noise	<ol style="list-style-type: none"> 1. Misaligned axle tube. 2. Bent or sprung axle shaft. 3. End-play in pinion bearings. 4. Excessive gear backlash between the ring gear and pinion. 5. Improper adjustment of pinion gear bearings. 6. Loose pinion yoke nut. 7. Scuffed gear tooth contact surfaces. 	<ol style="list-style-type: none"> 1. Inspect axle tube alignment. Correct as necessary. 2. Inspect and correct as necessary. 3. Refer to pinion pre-load information and correct as necessary. 4. Check adjustment of the ring gear and pinion backlash. Correct as necessary. 5. Adjust the pinion bearings pre-load. 6. Tighten the pinion yoke nut. 7. Inspect and replace as necessary.
Axle Shaft Broke	<ol style="list-style-type: none"> 1. Misaligned axle tube. 2. Vehicle overloaded. 3. Erratic clutch operation. 4. Grabbing clutch. 	<ol style="list-style-type: none"> 1. Replace the broken shaft after correcting tube mis-alignment. 2. Replace broken shaft and avoid excessive weight on vehicle. 3. Replace broken shaft and avoid or correct erratic clutch operation. 4. Replace broken shaft and inspect and repair clutch as necessary.
Differential Cracked	<ol style="list-style-type: none"> 1. Improper adjustment of the differential bearings. 2. Excessive ring gear backlash. 3. Vehicle overloaded. 4. Erratic clutch operation. 	<ol style="list-style-type: none"> 1. Replace case and inspect gears and bearings for further damage. Set differential bearing pre-load properly. 2. Replace case and inspect gears and bearings for further damage. Set ring gear backlash properly. 3. Replace case and inspect gears and bearings for further damage. Avoid excessive vehicle weight. 4. Replace case and inspect gears and bearings for further damage. Avoid erratic use of clutch.

DIAGNOSIS AND TESTING (Continued)

Condition	Possible Causes	Correction
Differential Gears Scored	<ol style="list-style-type: none"> 1. Insufficient lubrication. 2. Improper grade of lubricant. 3. Excessive spinning of one wheel/tire. 	<ol style="list-style-type: none"> 1. Replace scored gears. Fill differential with the correct fluid type and quantity. 2. Replace scored gears. Fill differential with the correct fluid type and quantity. 3. Replace scored gears. Inspect all gears, pinion bores, and shaft for damage. Service as necessary.
Loss Of Lubricant	<ol style="list-style-type: none"> 1. Lubricant level too high. 2. Worn axle shaft seals. 3. Cracked differential housing. 4. Worn pinion seal. 5. Worn/scored yoke. 6. Axle cover not properly sealed. 	<ol style="list-style-type: none"> 1. Drain lubricant to the correct level. 2. Replace seals. 3. Repair as necessary. 4. Replace seal. 5. Replace yoke and seal. 6. Remove, clean, and re-seal cover.
Axle Overheating	<ol style="list-style-type: none"> 1. Lubricant level low. 2. Improper grade of lubricant. 3. Bearing pre-loads too high. 4. Insufficient ring gear backlash. 	<ol style="list-style-type: none"> 1. Fill differential to correct level. 2. Fill differential with the correct fluid type and quantity. 3. Re-adjust bearing pre-loads. 4. Re-adjust ring gear backlash.
Gear Teeth Broke	<ol style="list-style-type: none"> 1. Overloading. 2. Erratic clutch operation. 3. Ice-spotted pavement. 4. Improper adjustments. 	<ol style="list-style-type: none"> 1. Replace gears. Examine other gears and bearings for possible damage. 2. Replace gears and examine the remaining parts for damage. Avoid erratic clutch operation. 3. Replace gears and examine remaining parts for damage. 4. Replace gears and examine remaining parts for damage. Ensure ring gear backlash is correct.

DIAGNOSIS AND TESTING (Continued)

Condition	Possible Causes	Correction
Axle Noise	<ol style="list-style-type: none"> 1. Insufficient lubricant. 2. Improper ring gear and pinion adjustment. 3. Unmatched ring gear and pinion. 4. Worn teeth on ring gear and/or pinion. 5. Loose pinion bearings. 6. Loose differential bearings. 7. Mis-aligned or sprung ring gear. 8. Loose differential bearing cap bolts. 9. Housing not machined properly. 	<ol style="list-style-type: none"> 1. Fill differential with the correct fluid type and quantity. 2. Check ring gear and pinion contact pattern. 3. Replace gears with a matched ring gear and pinion. 4. Replace ring gear and pinion. 5. Adjust pinion bearing pre-load. 6. Adjust differential bearing pre-load. 7. Measure ring gear run-out. Replace components as necessary. 8. Inspect differential components and replace as necessary. Ensure that the bearing caps are torqued to the proper specification. 9. Replace housing.

GEAR NOISE

Axle gear noise can be caused by insufficient lubricant, incorrect backlash, tooth contact, worn/damaged gears, or the carrier housing not having the proper offset and squareness.

Gear noise usually happens at a specific speed range. The noise can also occur during a specific type of driving condition. These conditions are acceleration, deceleration, coast, or constant load.

When road testing, first warm-up the axle fluid by driving the vehicle at least 5 miles and then accelerate the vehicle to the speed range where the noise is the greatest. Shift out-of-gear and coast through the peak-noise range. If the noise stops or changes greatly:

- Check for insufficient lubricant.
- Incorrect ring gear backlash.
- Gear damage.

Differential side gears and pinions can be checked by turning the vehicle. They usually do not cause noise during straight-ahead driving when the gears are unloaded. The side gears are loaded during vehicle turns. A worn pinion mate shaft can also cause a snapping or a knocking noise.

BEARING NOISE

The axle shaft, differential and pinion bearings can all produce noise when worn or damaged. Bearing noise can be either a whining, or a growling sound.

Pinion bearings have a constant-pitch noise. This noise changes only with vehicle speed. Pinion bearing noise will be higher pitched because it rotates at a

faster rate. Drive the vehicle and load the differential. If bearing noise occurs, the rear pinion bearing is the source of the noise. If the bearing noise is heard during a coast, the front pinion bearing is the source.

Worn or damaged differential bearings usually produce a low pitch noise. Differential bearing noise is similar to pinion bearing noise. The pitch of differential bearing noise is also constant and varies only with vehicle speed.

Axle shaft bearings produce noise and vibration when worn or damaged. The noise generally changes when the bearings are loaded. Road test the vehicle. Turn the vehicle sharply to the left and to the right. This will load the bearings and change the noise level. Where axle bearing damage is slight, the noise is usually not noticeable at speeds above 30 mph.

LOW SPEED KNOCK

Low speed knock is generally caused by a worn U-joint or by worn side-gear thrust washers. A worn pinion shaft bore will also cause low speed knock.

VIBRATION

Vibration at the rear of the vehicle is usually caused by a:

- Damaged drive shaft.
- Missing drive shaft balance weight(s).
- Worn or out-of-balance wheels.
- Loose wheel lug nuts.
- Worn U-joint(s).
- Loose/broken springs.

DIAGNOSIS AND TESTING (Continued)

- Damaged axle shaft bearing(s).
- Loose pinion gear nut.
- Excessive pinion yoke run out.
- Bent axle shaft(s).

Check for loose or damaged front-end components or engine/transmission mounts. These components can contribute to what appears to be a rear-end vibration. Do not overlook engine accessories, brackets and drive belts.

All driveline components should be examined before starting any repair.

Refer to Group 22, Wheels and Tires, for additional vibration information.

DRIVELINE SNAP

A snap or clunk noise when the vehicle is shifted into gear (or the clutch engaged), can be caused by:

- High engine idle speed.
- Transmission shift operation.
- Loose engine/transmission/transfer case mounts.
- Worn U-joints.
- Loose spring mounts.
- Loose pinion gear nut and yoke.
- Excessive ring gear backlash.
- Excessive side gear to case clearance.

The source of a snap or a clunk noise can be determined with the assistance of a helper. Raise the vehicle on a hoist with the wheels free to rotate. Instruct the helper to shift the transmission into gear. Listen for the noise, a mechanics stethoscope is helpful in isolating the source of a noise.

TRAC-LOK™ DIFFERENTIAL NOISE

The most common problem is a chatter noise when turning corners. Before removing a Trac-lok™ unit for repair, drain, flush and refill the axle with the specified lubricant. Refer to Lubricant change in this Group.

A container of Mopar® Trac-lok™ Lubricant (friction modifier) should be added after repair service or during a lubricant change.

After changing the lubricant, drive the vehicle and make 10 to 12 slow, figure-eight turns. This maneuver will pump lubricant through the clutches. This will correct the condition in most instances. If the chatter persists, clutch damage could have occurred.

TRAC-LOK™ TEST

WARNING: WHEN SERVICING VEHICLES WITH A TRAC-LOK™ DIFFERENTIAL DO NOT USE THE ENGINE TO TURN THE AXLE AND WHEELS. BOTH REAR WHEELS MUST BE RAISED AND THE VEHICLE SUPPORTED. A TRAC-LOK™ AXLE CAN EXERT ENOUGH FORCE IF ONE WHEEL IS IN CON-

TACT WITH A SURFACE TO CAUSE THE VEHICLE TO MOVE.

The differential can be tested without removing the differential case by measuring rotating torque. Make sure brakes are not dragging during this measurement.

(1) Place blocks in front and rear of both front wheels.

(2) Raise one rear wheel until it is completely off the ground.

(3) Engine off, transmission in neutral, and parking brake off.

(4) Remove wheel and bolt Special Tool 6790 to studs.

(5) Use torque wrench on special tool to rotate wheel and read rotating torque (Fig. 5).

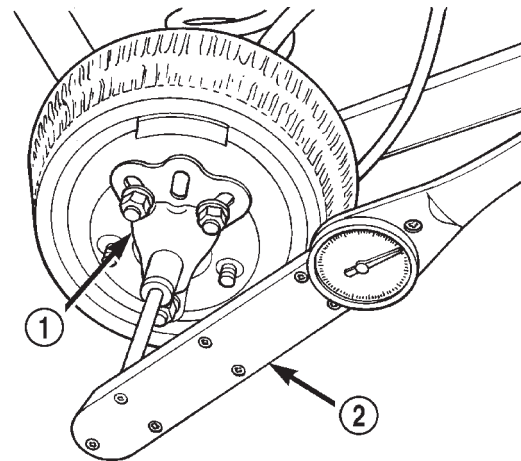

80a4d327

Fig. 5 Trac-lok™ Test —Typical

- 1 - SPECIAL TOOL 6790 WITH BOLT IN CENTER HOLE
- 2 - TORQUE WRENCH

(6) If rotating torque is less than 22 N-m (30 ft. lbs.) or more than 271 N-m (200 ft. lbs.) on either wheel the unit should be serviced.

SERVICE PROCEDURES

LUBRICANT CHANGE

- (1) Raise and support the vehicle.
- (2) Remove the lubricant fill hole plug from the differential housing cover.
- (3) Remove the differential housing cover and drain the lubricant from the housing.
- (4) Clean the housing cavity with a flushing oil, light engine oil, or lint free cloth. **Do not use water, steam, kerosene, or gasoline for cleaning.**
- (5) Remove the original sealant from the housing and cover surfaces.

SERVICE PROCEDURES (Continued)

(6) Apply a bead of Mopar® Silicone Rubber Sealant, or equivalent, to the housing cover (Fig. 6).

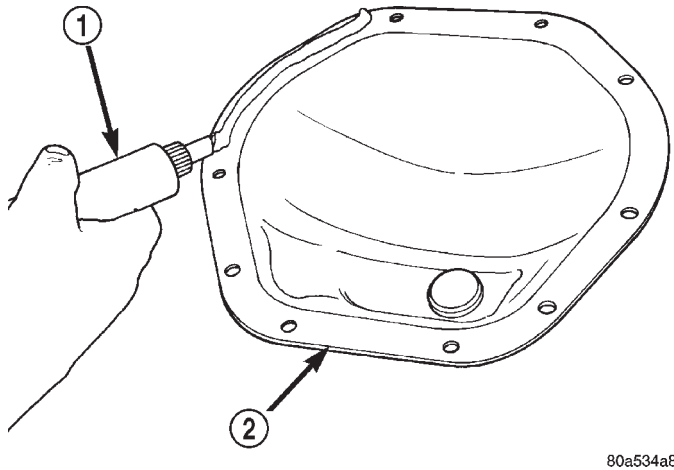

80a534a8

Fig. 6 Apply Sealant

- 1 - SEALANT
2 - AXLE HOUSING COVER

Install the housing cover within 5 minutes after applying the sealant.

(7) Install the cover and any identification tag. Tighten the cover bolts to 41 N·m (30 ft. lbs.) torque.

(8) For Trac-lok™ differentials, a quantity of Mopar® Trac-lok™ lubricant (friction modifier), or equivalent, must be added after repair service or a lubricant change. Refer to the Lubricant Specifications section of this group for the quantity necessary.

(9) Fill differential with the correct lubricant to bottom of the fill plug hole. Refer to the Lubricant Specifications section of this group for the quantity necessary.

CAUTION: Overfilling the differential can result in lubricant foaming and overheating.

(10) Install the fill hole plug and lower the vehicle.

(11) Trac-lok™ differential equipped vehicles should be road tested by making 10 to 12 slow figure-eight turns. This maneuver will pump the lubricant through the clutch discs to eliminate a possible chatter noise complaint.

REMOVAL AND INSTALLATION

REAR AXLE

REMOVAL

- (1) Raise and support the vehicle.
- (2) Position a suitable lifting device under the axle.
- (3) Secure axle to device.
- (4) Remove the wheels and tires.

(5) Remove the brake rotors and calipers from the axle. Refer to Group 5, Brakes, for proper procedures.

(6) Disconnect parking brake cables from brackets and lever.

(7) Remove wheel speed sensors, if necessary. Refer to Group 5, Brakes, for proper procedures.

(8) Disconnect the brake hose at the axle junction block. Do not disconnect the brake hydraulic lines at the calipers. Refer to Group 5, Brakes, for proper procedures.

(9) Disconnect the vent hose from the axle shaft tube.

(10) Mark the propeller shaft and yokes for installation alignment reference.

(11) Remove propeller shaft.

(12) Disconnect stabilizer bar links.

(13) Remove nut holding upper suspension arm to the rear axle ball joint.

(14) Using Remover 8278, separate the rear axle ball joint from the upper suspension arm (Fig. 7).

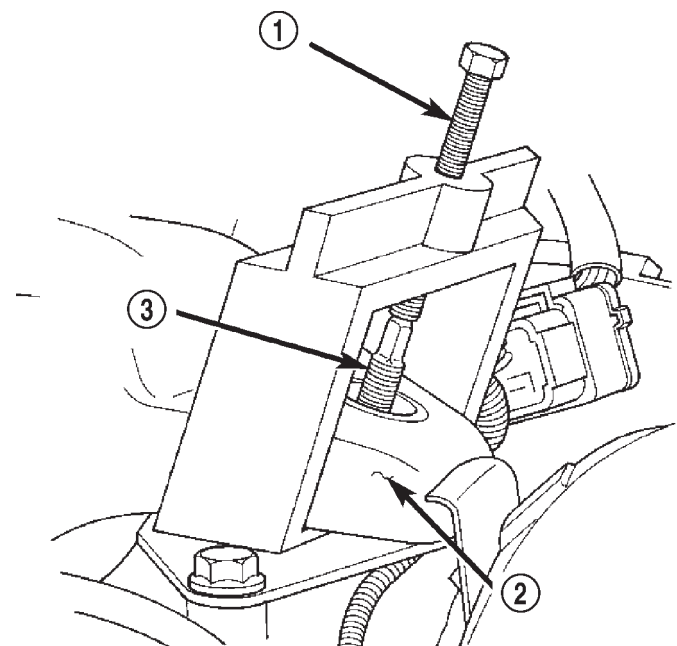

80b9a4df

Fig. 7 Separate Rear Axle Ball Joint

- 1 - REMOVER
2 - UPPER SUSPENSION ARM
3 - BALL JOINT STUD

(15) Disconnect shock absorbers from axle.

(16) Disconnect track bar.

(17) Disconnect lower suspension arms from the axle brackets.

(18) Separate the axle from the vehicle.

REMOVAL AND INSTALLATION (Continued)

INSTALLATION

NOTE: The weight of the vehicle must be supported by the springs before suspension arms and track bar fasteners can be tightened. If the springs are not at their normal ride position, vehicle ride height and handling could be affected.

- (1) Raise the axle with lifting device and align coil springs.
- (2) Position the lower suspension arms on the axle brackets. Install nuts and bolts, do not tighten bolts at this time.
- (3) Install the upper suspension arm to the rear axle ball joint.
- (4) Install nut to hold the upper suspension arm to the rear axle ball joint. Torque the nut to 122 N·m (90 ft.lbs.) (Fig. 8).

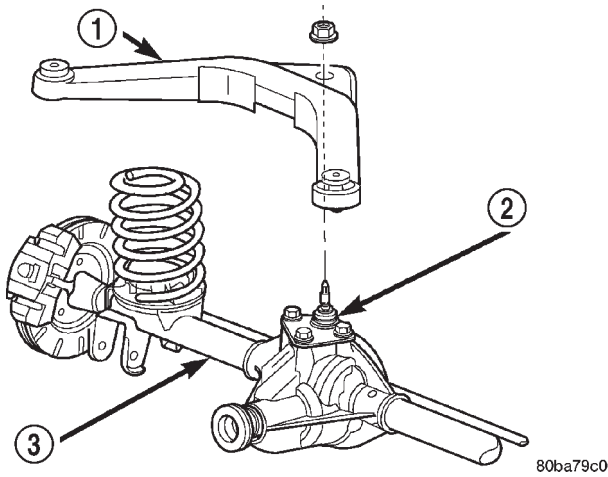

Fig. 8 Install Rear Ball Joint Nut

- 1 - UPPER SUSPENSION ARM
- 2 - REAR AXLE BALL JOINT
- 3 - REAR AXLE

- (5) Install track bar and attachment bolts, do not tighten bolts at this time.
- (6) Install shock absorbers and tighten nuts to 60 N·m (44 ft. lbs.) torque.
- (7) Install stabilizer bar links and tighten nuts to 36 N·m (27 ft. lbs.) torque.
- (8) Install the wheel speed sensors, if necessary. Refer to Group 5, Brakes, for proper procedures.
- (9) Connect parking brake cable to brackets and lever.
- (10) Install the brake rotors and calipers. Refer to Group 5, Brakes, for proper procedures.
- (11) Connect the brake hose to the axle junction block. Refer to Group 5, Brakes, for proper procedures.
- (12) Install axle vent hose.

- (13) Align propeller shaft and pinion yoke reference marks. Install U-joint straps and bolts. Tighten to 19 N·m (14 ft. lbs.) torque.
- (14) Install the wheels and tires.
- (15) Add gear lubricant, if necessary. Refer to Lubricant Specifications in this section for lubricant requirements.
- (16) Remove lifting device from axle and lower the vehicle.
- (17) Tighten lower suspension arm bolts to 177 N·m (130 ft. lbs.) torque.
- (18) Tighten track bar bolts to 100 N·m (74 ft. lbs.) torque.

PINION SHAFT SEAL

REMOVAL

- (1) Raise and support the vehicle.
- (2) Remove wheel and tire assemblies.
- (3) Remove the brake rotors and calipers. Refer to Group 5, Brakes, for proper procedures.
- (4) Mark the propeller shaft and pinion yoke for installation alignment reference.
- (5) Remove the propeller shaft from the yoke.
- (6) Rotate the pinion gear a minimum of ten times. Verify that the pinion rotates smoothly.
- (7) Measure the amount of torque necessary to rotate the pinion gear with a (in. lbs.) dial-type torque wrench. Record the torque reading for installation reference.
- (8) Using a short piece of pipe and Holder 6958 to hold the pinion yoke, remove the pinion nut and washer (Fig. 9).
- (9) Use Remover C-452 and Wrench C-3281 to remove the pinion yoke (Fig. 10).

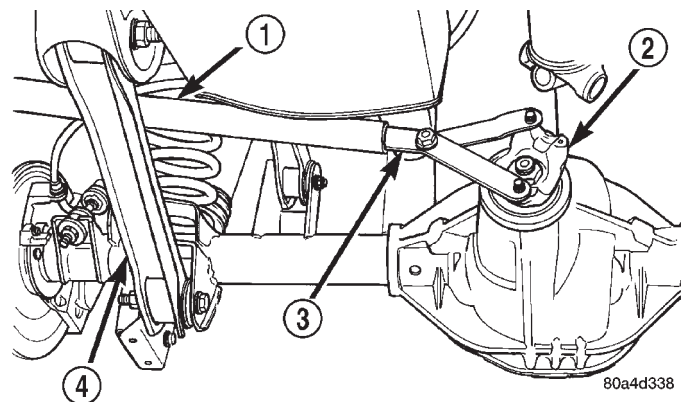
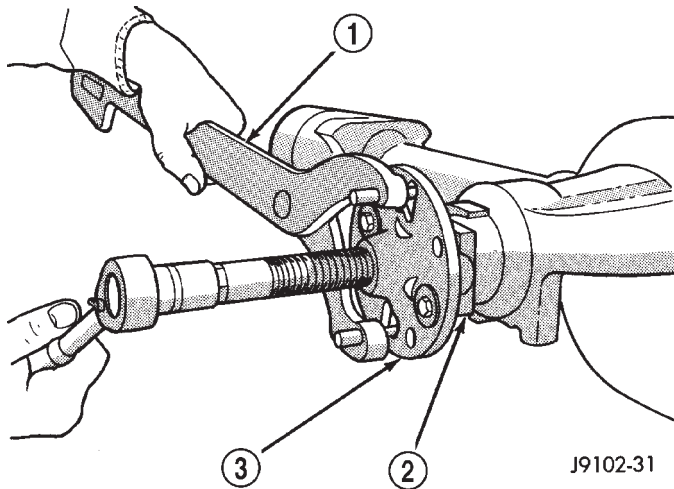

Fig. 9 Pinion Yoke Holder

- 1 - 1 in. PIPE
- 2 - PINION YOKE
- 3 - SPECIAL TOOL 6958
- 4 - LOWER CONTROL ARM

REMOVAL AND INSTALLATION (Continued)

**Fig. 10 Pinion Yoke Removal**

- 1 - SPECIAL TOOL C-3281
- 2 - YOKE
- 3 - SPECIAL TOOL C-452

(10) Use Remover 7794-A and slide hammer to remove the pinion gear seal (Fig. 11).

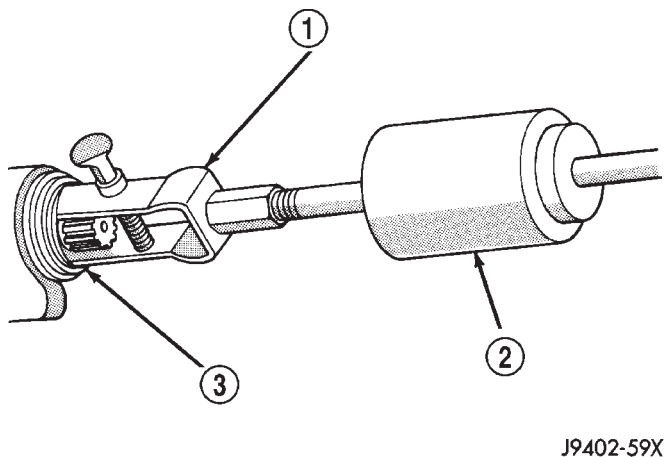
**Fig. 11 Seal Removal**

- 1 - SPECIAL TOOL 7794A
- 2 - SLIDE HAMMER
- 3 - PINION SEAL

INSTALLATION

(1) Apply a light coating of gear lubricant on the lip of pinion seal. Install seal with Installer C-3972-A and Handle C-4171 (Fig. 12).

(2) Install yoke on the pinion gear with Screw 8112, Cup 8109, and Holder 6958 (Fig. 13).

CAUTION: Do not exceed the minimum tightening torque when installing the pinion yoke at this point. Damage to the collapsible spacer or bearings may result.

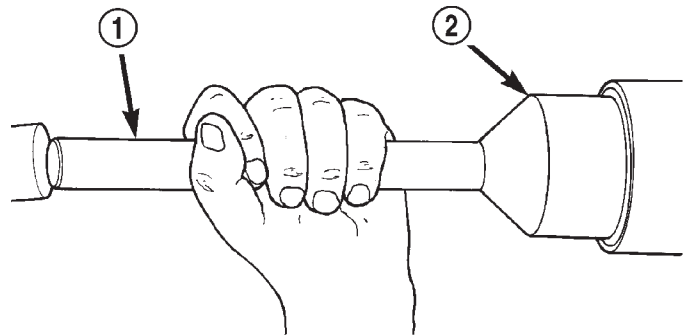

80a7e2be

Fig. 12 Pinion Seal Installation

- 1 - SPECIAL TOOL C-4171
- 2 - SPECIAL TOOL C-3972-A

(3) Install the yoke washer and a new nut on the pinion gear and tighten the pinion nut until there is zero bearing end-play.

(4) Tighten the nut to 271 N·m (200 ft. lbs.).

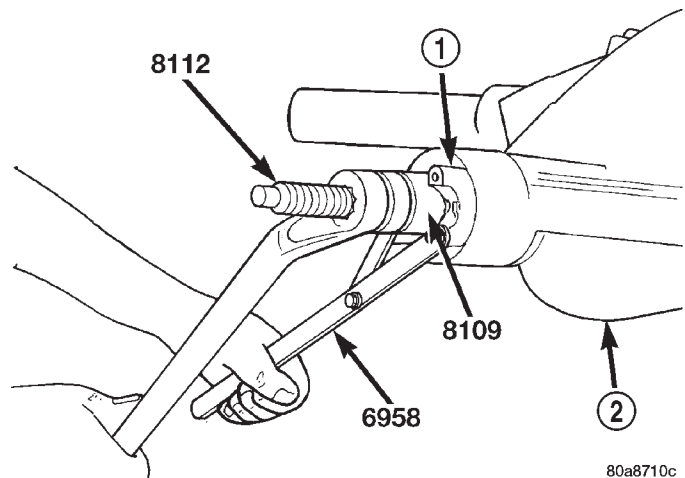

80a8710c

Fig. 13 Pinion Yoke Installation

- 1 - PINION YOKE
- 2 - AXLE HOUSING

CAUTION: Never loosen pinion gear nut to decrease pinion gear bearing rotating torque and never exceed specified preload torque. If preload torque or rotating torque is exceeded a new collapsible spacer must be installed. The torque sequence will then have to be repeated.

(5) Rotate the pinion gear a minimum of ten times. Verify that the pinion rotates smoothly. Rotate the pinion shaft using a (in. lbs.) torque wrench. Rotating torque should be equal to the reading recorded during removal plus an additional 0.56 N·m (5 in. lbs.) (Fig. 14).

(6) If the rotating torque is low, use Holder 6958 to hold the pinion yoke (Fig. 15), and tighten the pinion

REMOVAL AND INSTALLATION (Continued)

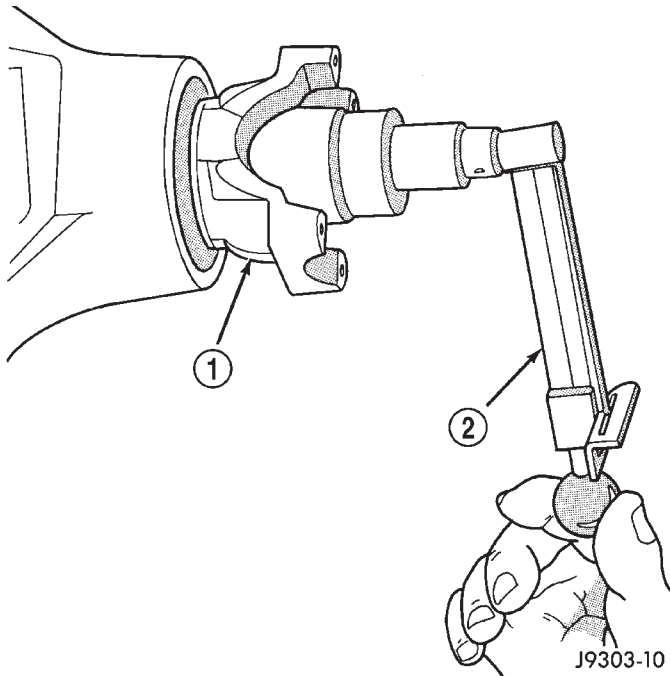

Fig. 14 Check Pinion Rotation Torque

- 1 - PINION YOKE
- 2 - INCH POUND TORQUE WRENCH

shaft nut in 6.8 N·m (5 ft. lbs.) increments until the proper rotating torque is achieved.

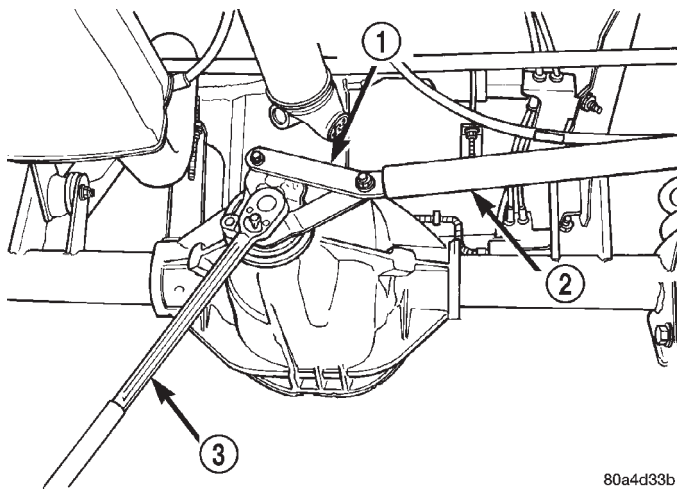

Fig. 15 Tightening Pinion Shaft Nut

- 1 - SPECIAL TOOL 6958
- 2 - 1 in. PIPE
- 3 - 3/4 DRIVE TORQUE WRENCH

CAUTION: If the maximum tightening torque is reached prior to reaching the required rotating torque, the collapsible spacer may have been damaged. Replace the collapsible spacer.

(7) Align the installation reference marks on the propeller shaft and yoke and install the propeller shaft.

(8) Add gear lubricant to the differential housing, if necessary. Refer to the Lubricant Specifications for gear lubricant requirements.

(9) Install the brake rotors and calipers. Refer to Group 5, Brakes, for proper procedures.

(10) Install wheel and tire assemblies.

(11) Lower the vehicle.

COLLAPSIBLE SPACER

REMOVAL W/PINION INSTALLED

- (1) Raise and support the vehicle.
- (2) Remove wheel and tire assemblies.
- (3) Remove rear brake rotors and calipers. Refer to Group 5, Brakes, for proper procedures.
- (4) Mark the propeller shaft and pinion yoke for installation reference.
- (5) Remove the propeller shaft from the yoke.
- (6) Rotate the pinion gear a minimum of ten times. Verify that the pinion rotates smoothly.
- (7) Measure the amount of torque necessary to rotate the pinion gear with a (in. lbs.) dial-type torque wrench. Record the torque reading for installation reference.

(8) Using a short piece of pipe and Holder 6958 to hold the pinion yoke, remove the pinion nut and washer (Fig. 16).

(9) Use Remover C-452 and Wrench C-3281 to remove the pinion yoke (Fig. 17).

(10) Use Remover 7794-A and slide hammer to remove the pinion shaft seal (Fig. 18).

(11) Remove the front pinion bearing using a pair of suitable pick tools to pull the bearing straight off the pinion gear shaft. It may be necessary to lightly tap the end of the pinion gear with a rawhide or rubber mallet if the bearing becomes bound on the pinion shaft.

(12) Remove the collapsible spacer.

REMOVAL W/PINION REMOVED

- (1) Raise and support the vehicle.
- (2) Remove wheel and tire assemblies.
- (3) Remove rear brake rotors and calipers. Refer to Group 5, Brakes, for proper procedures.
- (4) Mark the propeller shaft and pinion yoke for installation reference.
- (5) Remove the propeller shaft from the yoke.
- (6) Rotate the pinion gear a minimum of ten times. Verify that the pinion rotates smoothly.
- (7) Measure the amount of torque necessary to rotate the pinion gear with a (in. lbs.) dial-type torque wrench. Record the torque reading for installation reference.

REMOVAL AND INSTALLATION (Continued)

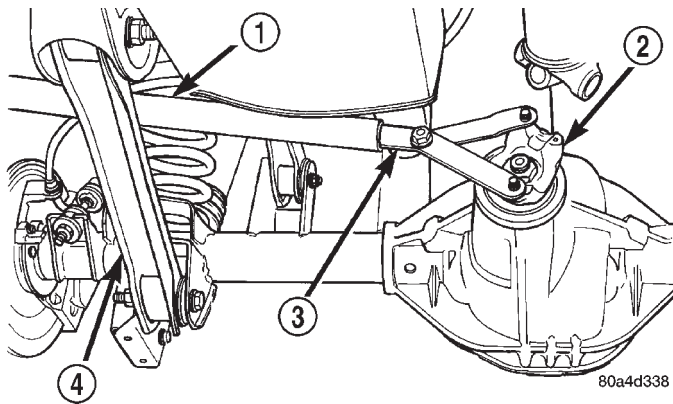
**Fig. 16 Pinion Yoke Holder**

- 1 - 1 in. PIPE
- 2 - PINION YOKE
- 3 - SPECIAL TOOL 6958
- 4 - LOWER CONTROL ARM

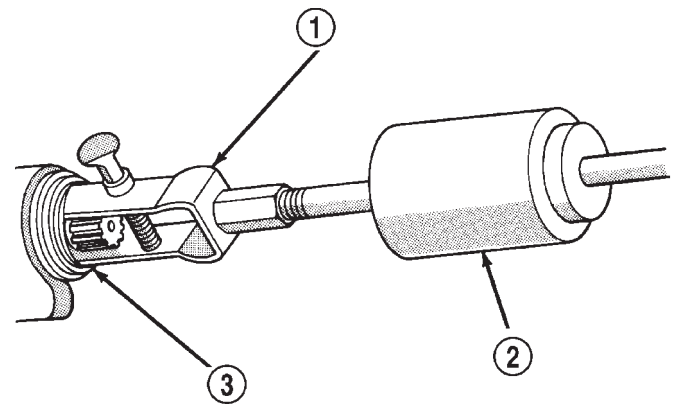
**Fig. 18 Seal Removal**

- 1 - SPECIAL TOOL 7794A
- 2 - SLIDE HAMMER
- 3 - PINION SEAL

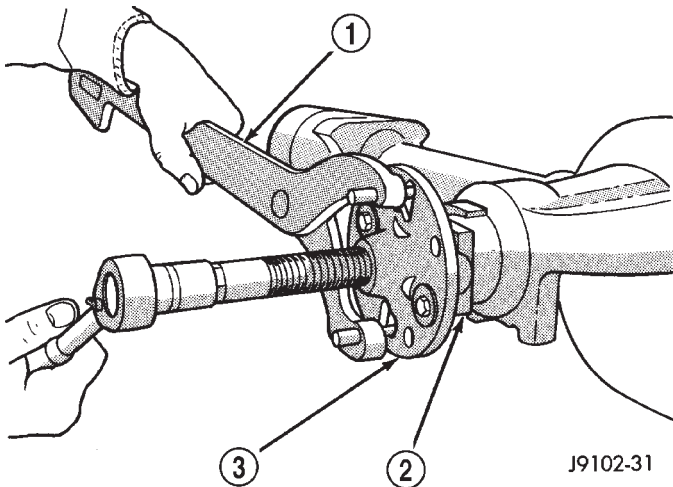
**Fig. 17 Pinion Yoke Removal**

- 1 - SPECIAL TOOL C-3281
- 2 - YOKE
- 3 - SPECIAL TOOL C-452

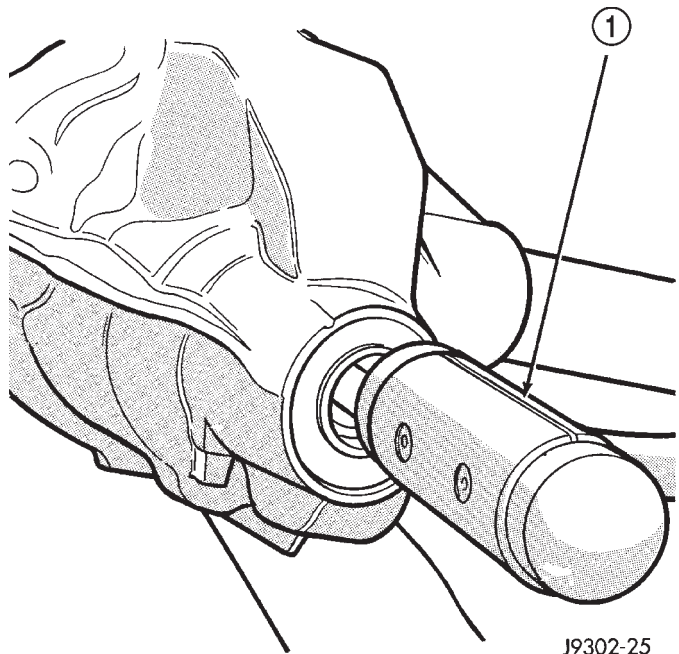
**Fig. 19 Remove Pinion Gear**

- 1 - RAWHIDE HAMMER

(8) Remove differential assembly from axle housing.

(9) Using Holder 6958 to hold yoke and a short length of 1 in. pipe, remove the pinion yoke nut and washer (Fig. 16).

(10) Using Remover C-452 and Wrench C-3281, remove the pinion yoke from pinion shaft (Fig. 17).

(11) Remove the pinion gear from housing (Fig. 19). Catch the pinion with your hand to prevent it from falling and being damaged.

(12) Remove collapsible spacer from pinion shaft.

INSTALLATION

(1) Install a new collapsible preload spacer on pinion shaft (Fig. 20).

(2) If pinion gear was removed, install pinion gear in housing.

(3) Install pinion front bearing, if necessary.

(4) Apply a light coating of gear lubricant on the lip of pinion seal. Install seal with Installer C-3972-A and Handle C-4171 (Fig. 21).

(5) Install yoke with Screw 8112, Cup 8109, and Holder 6958 (Fig. 22).

(6) If the original pinion bearings are being used, install differential assembly and axle shafts, if necessary.

REMOVAL AND INSTALLATION (Continued)

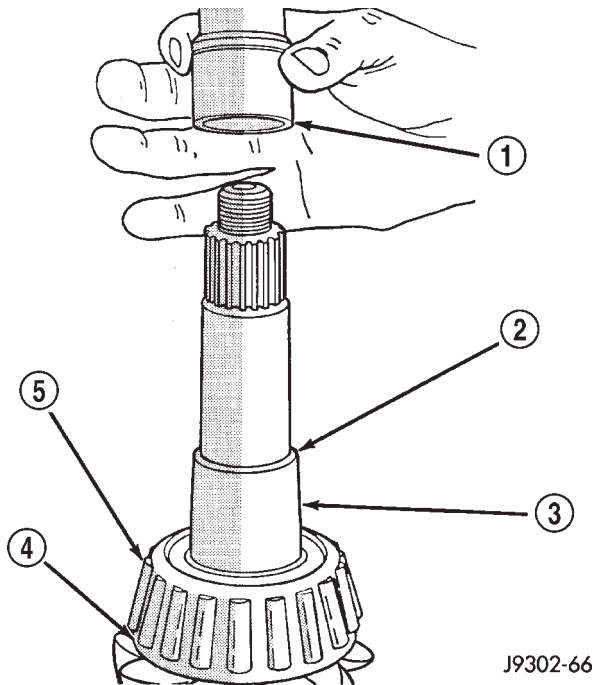

J9302-66

Fig. 20 Collapsible Preload Spacer

- 1 - COLLAPSIBLE SPACER
- 2 - SHOULDER
- 3 - PINION GEAR
- 4 - OIL SLINGER
- 5 - REAR BEARING

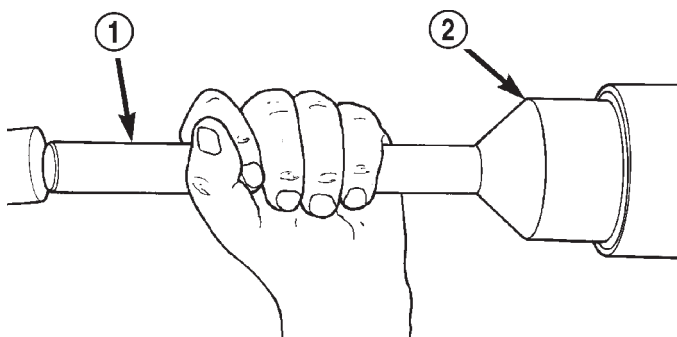

80a7e2be

Fig. 21 Pinion Seal Installation

- 1 - SPECIAL TOOL C-4171
- 2 - SPECIAL TOOL C-3972-A

NOTE: If new pinion bearings were installed, do not install the differential assembly and axle shafts until after the pinion bearing preload and rotating torque are set.

(7) Install the yoke washer and a new nut on the pinion gear. Tighten the pinion nut until there is zero bearing end-play.

(8) Tighten the nut to 271 N·m (200 ft. lbs.).

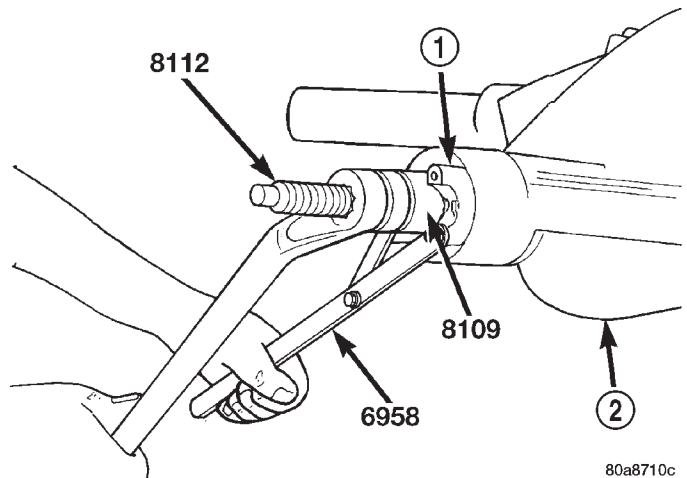

80a8710c

Fig. 22 Pinion Yoke Installation

- 1 - PINION YOKE
- 2 - AXLE HOUSING

CAUTION: Never loosen pinion gear nut to decrease pinion gear bearing rotating torque and never exceed specified preload torque. If preload torque or rotating torque is exceeded a new collapsible spacer must be installed. The torque sequence will then have to be repeated.

(9) Using yoke holder 6958, a short length of 1 in. pipe, and a torque wrench set at 474 N·m (350 ft. lbs.), crush collapsible spacer until bearing end play is taken up (Fig. 23).

NOTE: If more than 474 N·m (350 ft. lbs.) of torque is necessary to remove the bearing end play, the collapsible spacer is defective and must be replaced.

(10) Slowly tighten the nut in 6.8 N·m (5 ft. lbs.) increments until the required rotating torque is achieved. Measure the rotating torque frequently to avoid over crushing the collapsible spacer (Fig. 24).

(11) Rotate the pinion gear a minimum of ten times. Verify that the pinion rotates smoothly. Check rotating torque with an inch pound torque wrench (Fig. 24). The torque necessary to rotate the pinion gear should be:

- Original Bearings — The reading recorded during removal, plus an additional 0.56 N·m (5 in. lbs.).
- New Bearings — 1.7 to 3.4 N·m (15 to 30 in. lbs.).

(12) Install differential assembly and axle shafts, if necessary.

(13) Align marks made previously on yoke and propeller shaft and install propeller shaft.

(14) Install rear brake rotors and calipers. Refer to Group 5, Brakes, for proper procedures.

REMOVAL AND INSTALLATION (Continued)

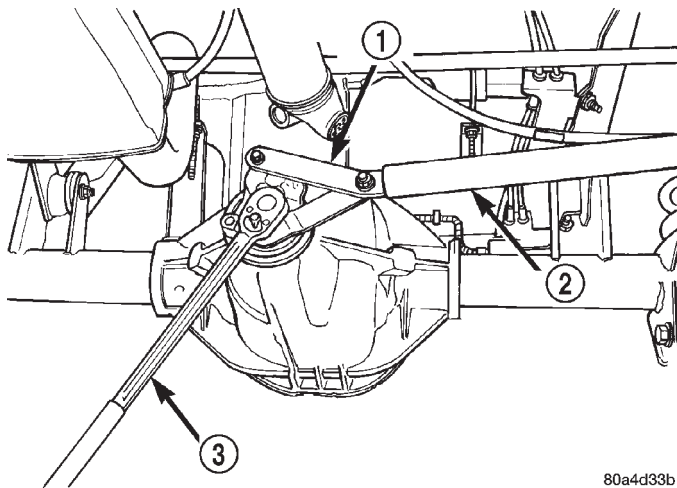

80a4d33b

Fig. 23 Tightening Pinion Nut

- 1 - SPECIAL TOOL 6958
 2 - 1 in. PIPE
 3 - 3/4 DRIVE TORQUE WRENCH

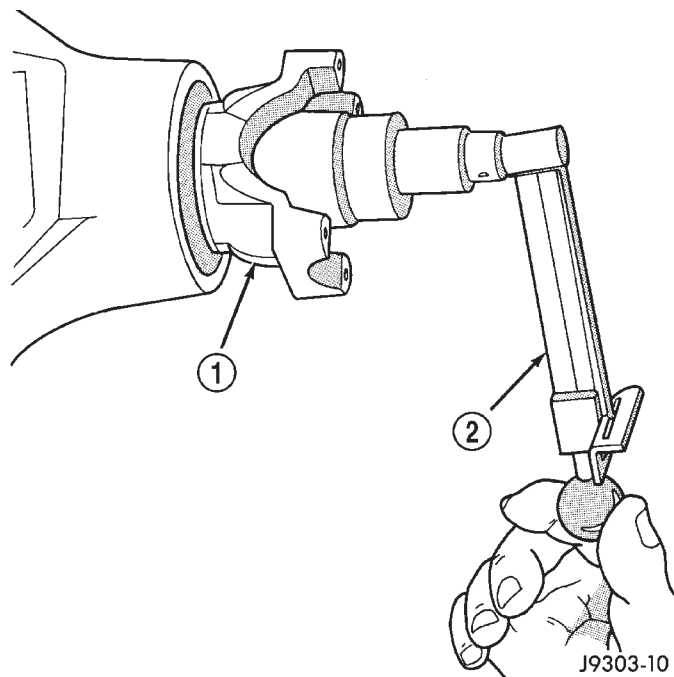

J9303-10

Fig. 24 Check Pinion Gear Rotation Torque

- 1 - PINION YOKE
 2 - INCH POUND TORQUE WRENCH

(15) Add gear lubricant, if necessary. Refer to Lubricant Specifications of this section for lubricant requirements.

- (16) Install wheel and tire assemblies.
 (17) Lower vehicle.

AXLE SHAFT**REMOVAL**

- (1) Raise and support vehicle. Ensure that the transmission is in neutral.
- (2) Remove wheel and tire assembly.
- (3) Remove brake caliper and rotor. Refer to Group 5, Brakes, for proper procedure.
- (4) From the rear of the axle flange, remove the nuts holding axle retaining plate to axle tube.
- (5) Using Slide Hammer 7420, Adapter 6790, and suitable lug nuts, pull axle shaft from vehicle.

NOTE: It is normal that the axle bearing race is loose in the axle tube.

INSTALLATION

- (1) Insert axle into opening at end of axle tube.
- (2) Align flat area on axle shaft retaining plate upward.
- (3) Insert the retaining plate studs into the brake backing plate and the axle tube flange.
- (4) Install nuts to hold axle retaining plate to axle tube. Tighten the nuts to 61 N·m (45 ft. lbs.).
- (5) Install brake caliper and rotor. Refer to Group 5, Brakes, for proper procedures.
- (6) Install wheel and tire.
- (7) Check and fill the gear lubricant. Refer to the Lubricant Specifications for gear lubricant requirements.
- (8) Lower vehicle.

AXLE SHAFT SEAL AND BEARING**REMOVAL**

- (1) Remove axle shaft from vehicle.

NOTE: It is normal that the axle bearing race is loose in the axle tube.

- (2) Remove the studs from the axle retaining plate.
- (3) Using a 3/8 in. dia. drill bit, drill a shallow hole into soft steel axle bearing retaining ring (Fig. 25). If possible, use a drill depth stop to avoid marking axle.
- (4) Using a suitable cold chisel, cut retaining ring across drilled hole. (Fig. 26)
- (5) Slide retaining ring from axle shaft.
- (6) Using Splitter 1130 placed between the seal and bearing and a suitable Arbor Press, press bearing from the axle shaft (Fig. 27).
- (7) Slide seal from axle.
- (8) Slide retaining plate from axle shaft.

REMOVAL AND INSTALLATION (Continued)

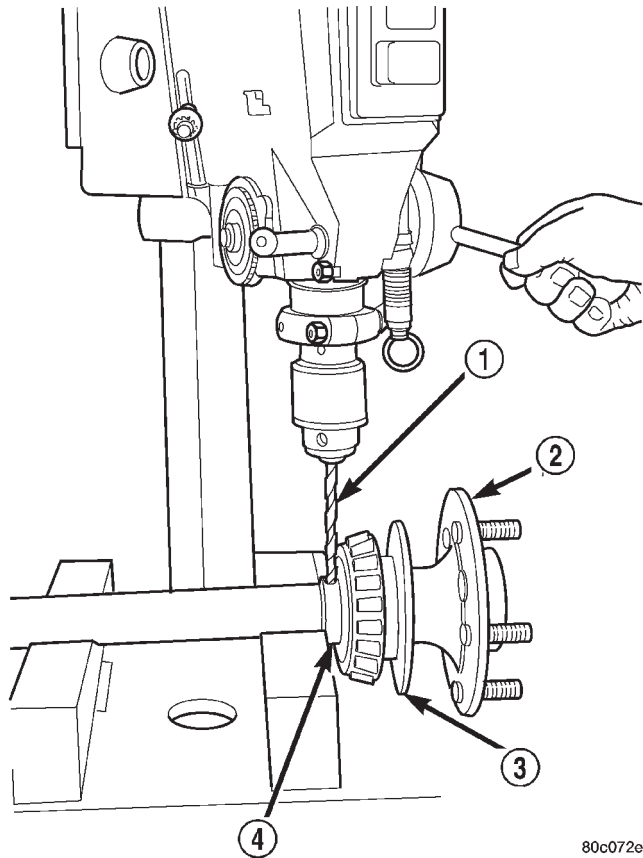

Fig. 25 Drill Retaining Ring

- 1 - 3/8 IN DIA DRILL BIT
- 2 - AXLE
- 3 - RETAINING PLATE
- 4 - SOFT METAL RETAINING RING

80c072eb

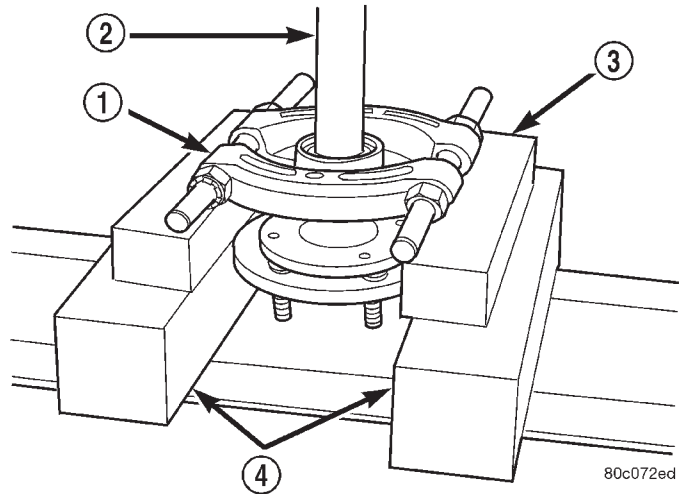

Fig. 27 Axle Bearing and Seal Remove

- 1 - AXLE
- 2 - PRESS PLATES
- 3 - BLOCKS
- 4 - SPECIAL TOOL 1130

80c072ed

INSTALLATION

(1) Using a suitable straight edge, verify flatness of axle shaft retaining plate. Replace plate if warped.
 (2) Install the studs back into the retaining plate. If the studs are loose in the plate, replace the retaining plate.

(3) Install retaining plate on axle (Fig. 28).
 (4) Apply a coat of multi-purpose grease on sealing surface of axle seal.

(5) Install seal on axle with cavity away from retaining plate (Fig. 28).

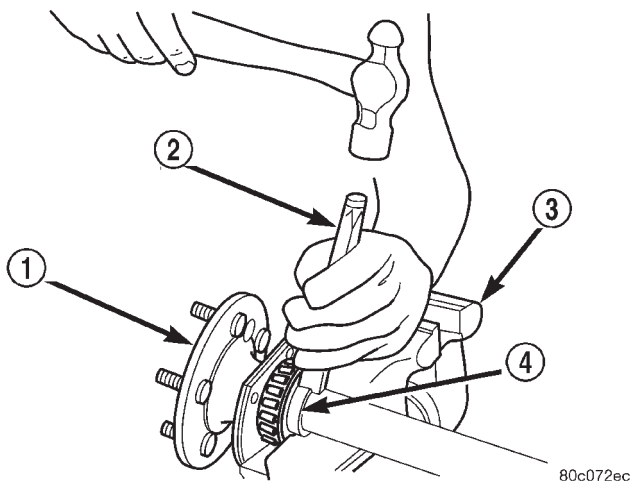

Fig. 26 Cut Retaining Ring

- 1 - AXLE
- 2 - COLD CHISEL
- 3 - VISE
- 4 - RETAINING RING

80c072ec

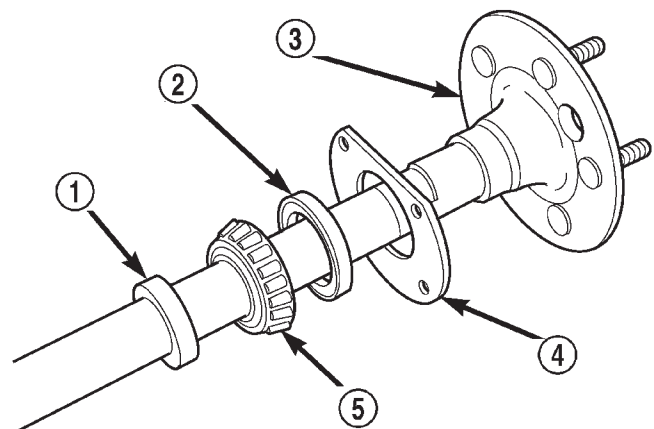

Fig. 28 Axle Bearing and Seal Components

- 1 - RETAINING RING
- 2 - SEAL
- 3 - AXLE
- 4 - RETAINING PLATE
- 5 - AXLE BEARING

80c072ee

REMOVAL AND INSTALLATION (Continued)

(6) Lubricate bearing with Mopar® Wheel Bearing Grease, or equivalent. Wipe excess grease from the bearing.

(7) Slide bearing onto axle shaft (Fig. 28).

(8) Using Installer 7913 and shop press, press bearing onto axle shaft (Fig. 29).

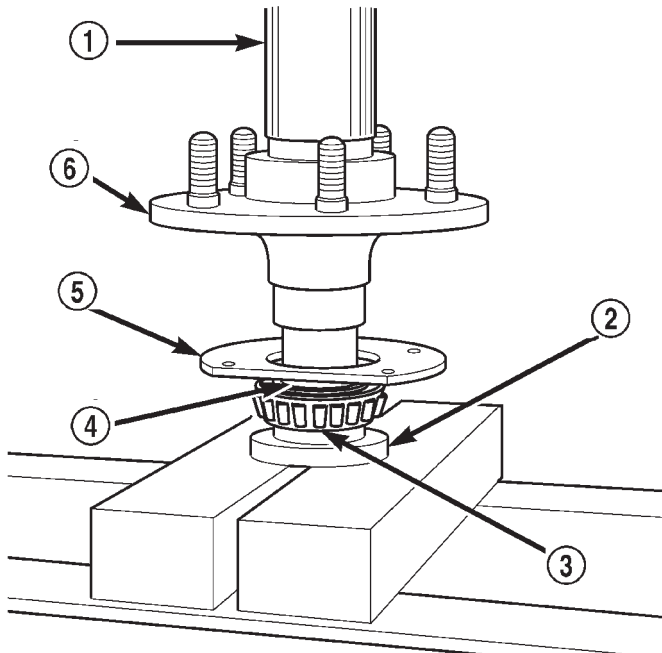

Fig. 29 Press Bearing Onto Axle

- 1 - PRESS RAM
- 2 - SPECIAL TOOL 7913
- 3 - AXLE BEARING
- 4 - SEAL
- 5 - RETAINING PLATE
- 6 - AXLE

(9) Using Installer 7913 and shop press, press soft metal retaining ring onto axle shaft (Fig. 30).

(10) Install axle in vehicle.

DIFFERENTIAL

REMOVAL

- (1) Raise and support vehicle.
- (2) Remove the lubricant fill hole plug from the differential housing cover.
- (3) Remove the differential housing cover and allow fluid to drain.
- (4) Remove axle shafts.
- (5) Note the installation reference letters stamped on the bearing caps and housing machined sealing surface (Fig. 31).
- (6) Loosen the differential bearing cap bolts.
- (7) Position Spreader W-129-B, utilizing some items from Adapter set 6987, with the tool dowel pins seated in the locating holes (Fig. 32). Install the holddown clamps and tighten the tool turnbuckle finger-tight.

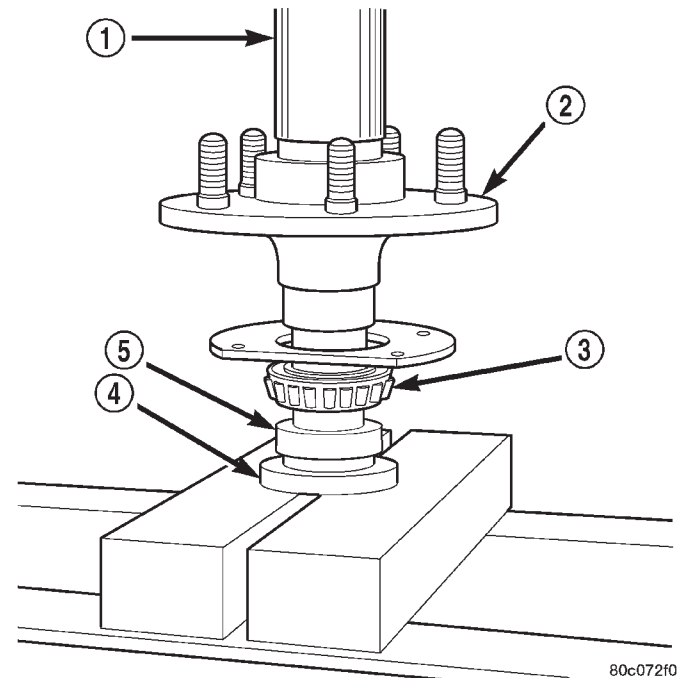

Fig. 30 Press Bearing Retaining Ring On Axle

- 1 - PRESS RAM
- 2 - AXLE
- 3 - AXLE BEARING
- 4 - SPECIAL TOOL 7913
- 5 - SOFT METAL RETAINING RING

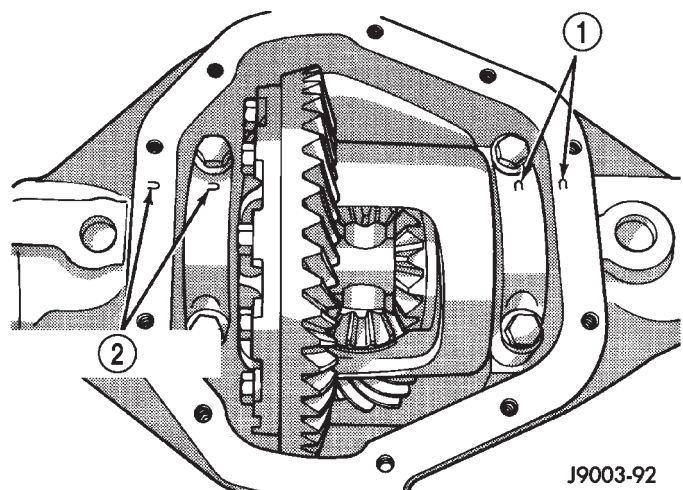
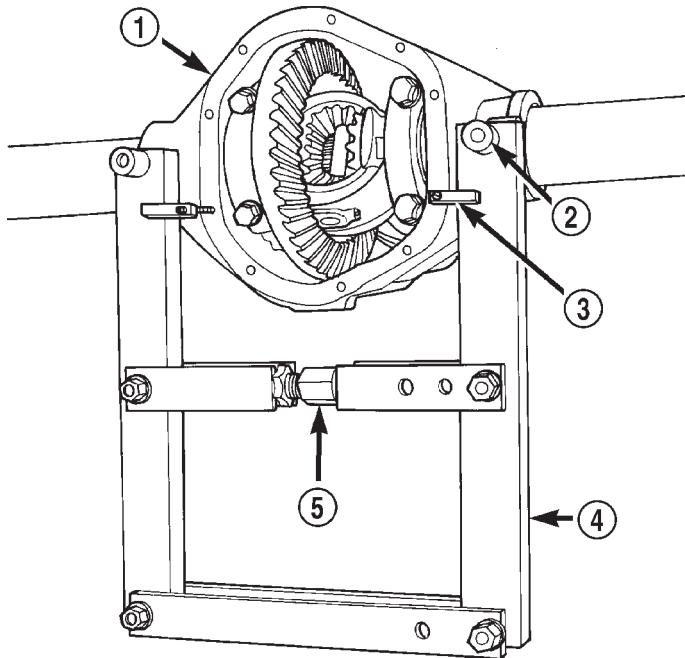

Fig. 31 Bearing Cap Identification

- 1 - INSTALLATION REFERENCE LETTERS
- 2 - INSTALLATION REFERENCE LETTERS

(8) Install a Pilot Stud C-3288-B at the left side of the differential housing. Attach Dial Indicator C-3339 to pilot stud. Load the indicator plunger against the opposite side of the housing (Fig. 33) and zero the indicator.

REMOVAL AND INSTALLATION (Continued)



80a534c5

Fig. 32 Install Axle Housing Spreader

- 1 - AXLE HOUSING
- 2 - DOWEL
- 3 - SAFETY HOLD DOWN
- 4 - SPECIAL TOOL W-129-B
- 5 - TURNBUCKLE

(9) Spread the housing enough to remove the differential case from the housing. Measure the distance with the dial indicator (Fig. 34).

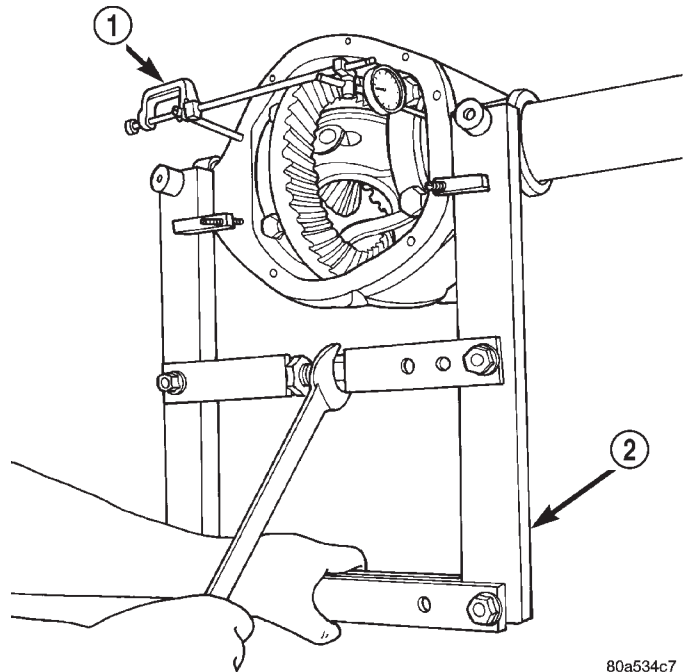

80a534c7

Fig. 34 Spread Axle Housing

- 1 - SPECIAL TOOL C-3339
- 2 - SPECIAL TOOL W-129-B

CAUTION: Do not spread over 0.38 mm (0.015 in). If the housing is over-spread, it could be distorted or damaged.

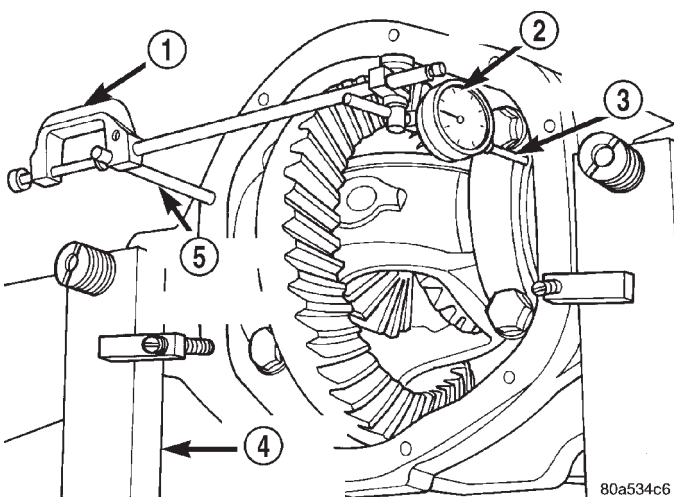

80a534c6

Fig. 33 Install Dial Indicator

- 1 - SPECIAL TOOL C-3339
- 2 - DIAL INDICATOR
- 3 - LEVER ADAPTER
- 4 - SPECIAL TOOL W-129-B
- 5 - SPECIAL TOOL C-3288-B

(10) Remove the dial indicator.
 (11) While holding the differential case in position, remove the differential bearing cap bolts and caps.
 (12) Remove the differential from the housing. Ensure that the differential bearing cups remain in position on the differential bearings (Fig. 35).

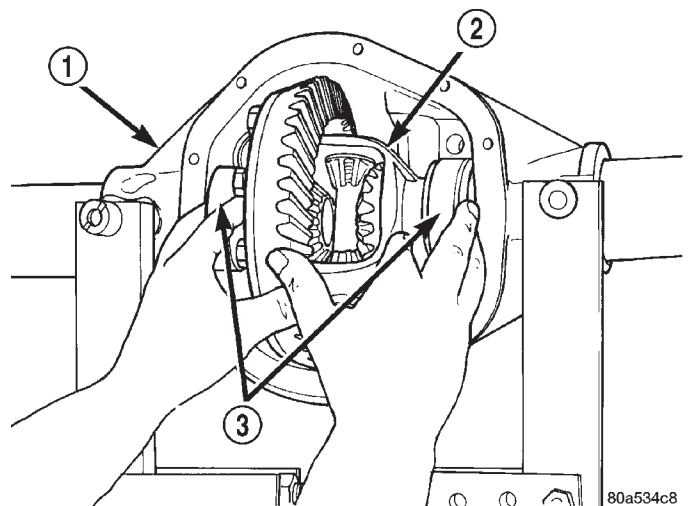

80a534c8

Fig. 35 Differential Case Removal

- 1 - AXLE HOUSING
- 2 - DIFFERENTIAL CASE
- 3 - BEARING CUPS

REMOVAL AND INSTALLATION (Continued)

(13) Mark or tag the differential bearing cups to indicate which side of the differential they were removed from.

(14) Retrieve differential case preload shims from axle housing. Mark or tag the differential case preload shims to indicate which side of the differential they were removed from.

(15) Remove spreader from housing.

INSTALLATION

If replacement differential bearings or differential case are being installed, differential side bearing shim requirements may change. Refer to the Differential Bearing Preload and Gear Backlash procedures in this section to determine the proper shim selection.

(1) Position Spreader W-129-B, utilizing some items from Adapter set 6987, with the tool dowel pins seated in the locating holes (Fig. 36). Install the hold-down clamps and tighten the tool turnbuckle finger-tight.

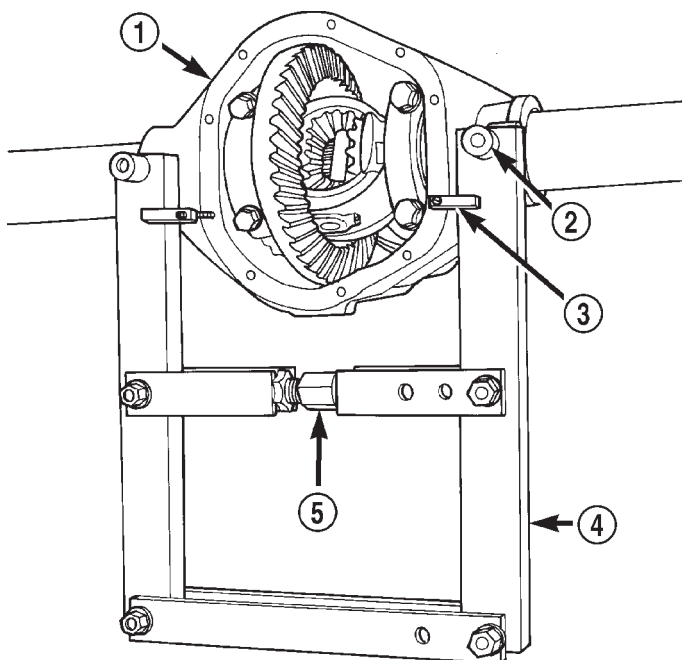

Fig. 36 Install Axle Housing Spreader

80a534c5

- 1 - AXLE HOUSING
- 2 - DOWEL
- 3 - SAFETY HOLD DOWN
- 4 - SPECIAL TOOL W-129-B
- 5 - TURNBUCKLE

(2) Install a Pilot Stud C-3288-B at the left side of the differential housing. Attach Dial Indicator C-3339 to pilot stud. Load the indicator plunger against the opposite side of the housing (Fig. 33) and zero the indicator.

CAUTION: Do not spread over 0.38 mm (0.015 in). If the housing is over-spread, it could be distorted or damaged.

(3) Spread the housing enough to install the case in the housing. Measure the distance with the dial indicator (Fig. 34).

(4) Remove the dial indicator.

(5) Install differential case in the housing. Ensure that the differential bearing cups remain in position on the differential bearings and that the preload shims remain between the face of the bearing cup and the housing. Tap the differential case to ensure the bearings cups and shims are fully seated in the housing.

(6) Install the bearing caps at their original locations (Fig. 37).

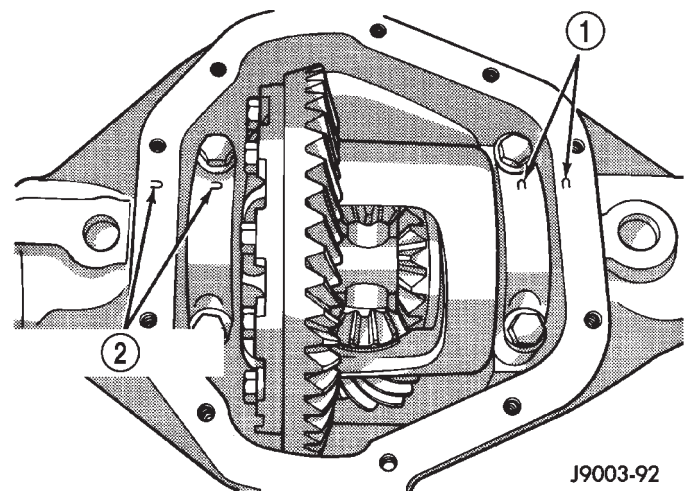

J9003-92

Fig. 37 Differential Bearing Cap Reference Letters

- 1 - INSTALLATION REFERENCE LETTERS
- 2 - INSTALLATION REFERENCE LETTERS

- (7) Loosely install differential bearing cap bolts.
- (8) Remove axle housing spreader.
- (9) Tighten the bearing cap bolts to 77 N·m (57 ft. lbs.) torque.
- (10) Install the axle shafts.

DIFFERENTIAL SIDE BEARINGS

REMOVAL

- (1) Remove differential case from axle housing.
- (2) Remove the bearings from the differential case with Puller/Press C-293-PA, Adapter Blocks 8352, and Plug SP-3289 (Fig. 38).

INSTALLATION

If replacement differential side bearings or differential case are being installed, differential side bearing shim requirements may change. Refer to the Differential Bearing Preload and Gear Backlash procedures in this section to determine the proper shim selection.

- (1) Using Installer C-3716-A and Handle C-4171, install differential side bearings (Fig. 39).
- (2) Install differential in axle housing.

REMOVAL AND INSTALLATION (Continued)

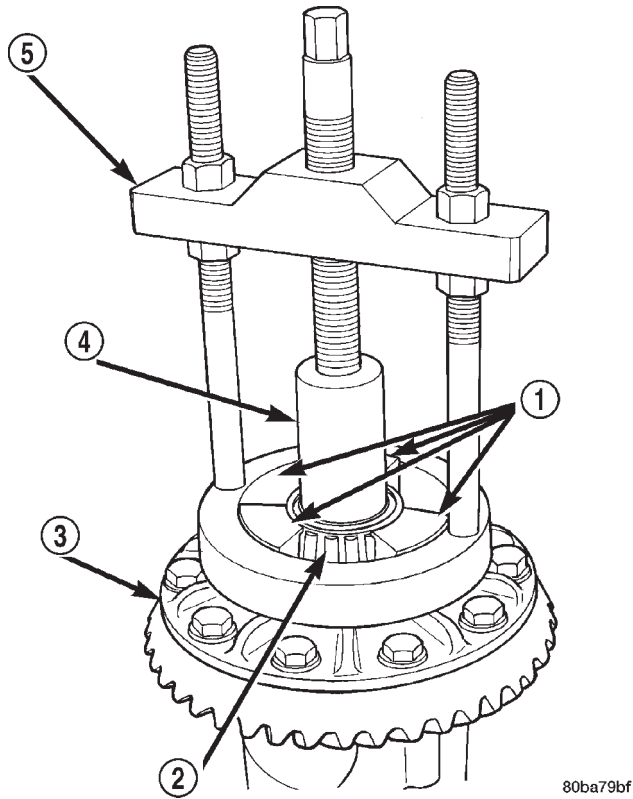

Fig. 38 Differential Bearing Removal

- 1 - SPECIAL TOOL 8352
- 2 - BEARING
- 3 - DIFFERENTIAL
- 4 - SPECIAL TOOL SP-3289
- 5 - SPECIAL TOOL C-293-PA

RING GEAR

NOTE: The ring and pinion gears are serviced as a matched set. Do not replace the ring gear without replacing the pinion gear.

REMOVAL

- (1) Remove differential from axle housing.
- (2) Place differential case in a suitable vise with soft metal jaw protectors. (Fig. 40)
- (3) Remove bolts holding ring gear to differential case.
- (4) Using a soft hammer, drive ring gear from differential case (Fig. 40).

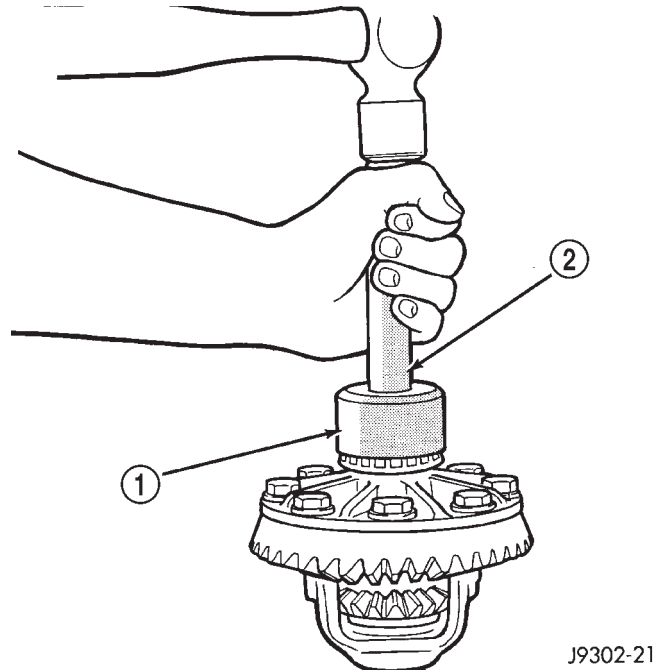

Fig. 39 Differential Side Bearing Installation

- 1 - SPECIAL TOOL C-3716-A
- 2 - SPECIAL TOOL C-4171

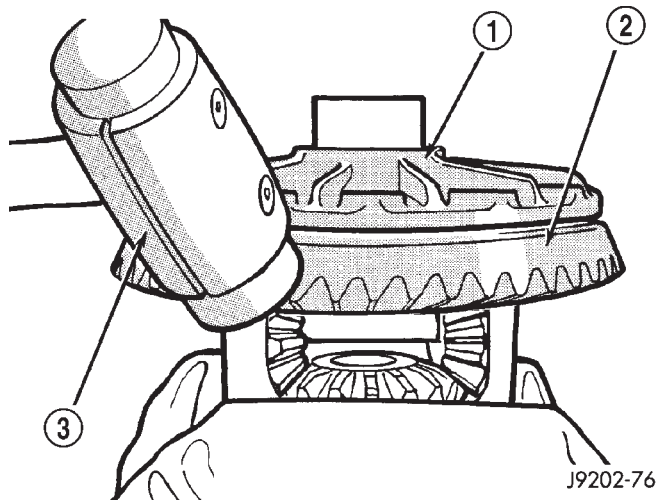

Fig. 40 Ring Gear Removal

- 1 - CASE
- 2 - RING GEAR
- 3 - RAWHIDE HAMMER

REMOVAL AND INSTALLATION (Continued)

INSTALLATION

CAUTION: Do not reuse the bolts that held the ring gear to the differential case. The bolts can fracture causing extensive damage.

(1) Invert the differential case and start two ring gear bolts. This will provide case-to-ring gear bolt hole alignment.

(2) Invert the differential case in the vise.

(3) Install new ring gear bolts and alternately tighten to 129–142 N·m (95–105 ft. lbs.) torque (Fig. 41).

(4) Install differential in axle housing and verify gear mesh and contact pattern.

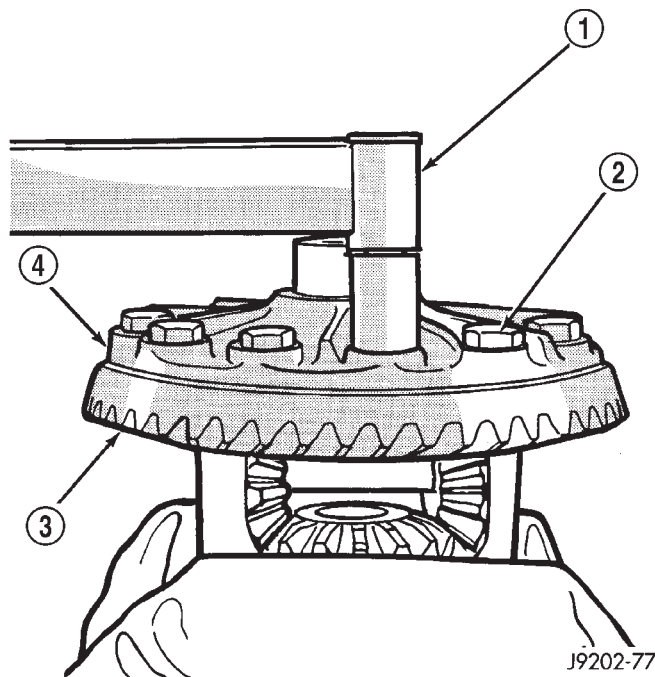

Fig. 41 Ring Gear Bolt Installation

- 1 - TORQUE WRENCH
- 2 - RING GEAR BOLT
- 3 - RING GEAR
- 4 - CASE

PINION GEAR

NOTE: The ring and pinion gears are serviced as a matched set. Do not replace the pinion gear without replacing the ring gear.

REMOVAL

(1) Remove differential from the axle housing.

(2) Mark pinion yoke and propeller shaft for installation alignment.

(3) Disconnect propeller shaft from pinion yoke. Using suitable wire, tie propeller shaft to underbody.

(4) Using Holder 6958 to hold yoke and a short length of 1 in. pipe, remove the pinion yoke nut and washer (Fig. 42).

(5) Using Remover C-452 and Wrench C-3281, remove the pinion yoke from pinion shaft (Fig. 43).

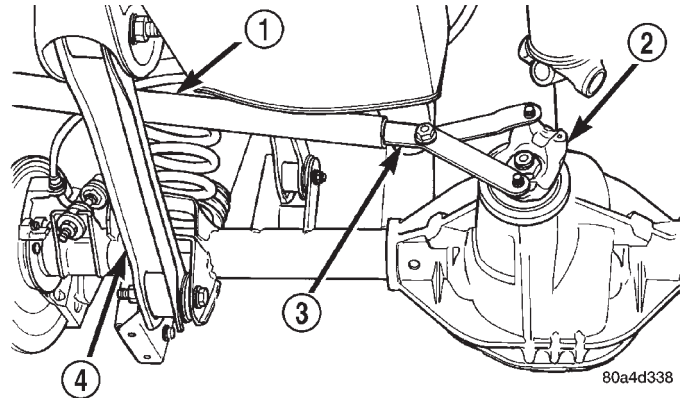

Fig. 42 Pinion Yoke Holder

- 1 - 1 in. PIPE
- 2 - PINION YOKE
- 3 - SPECIAL TOOL 6958
- 4 - LOWER CONTROL ARM

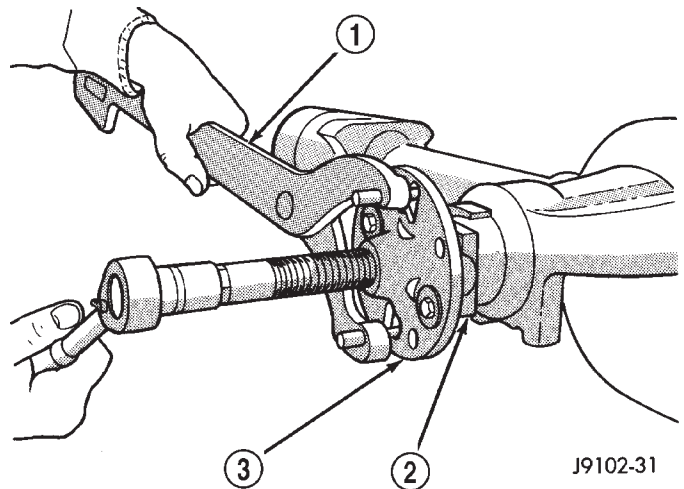
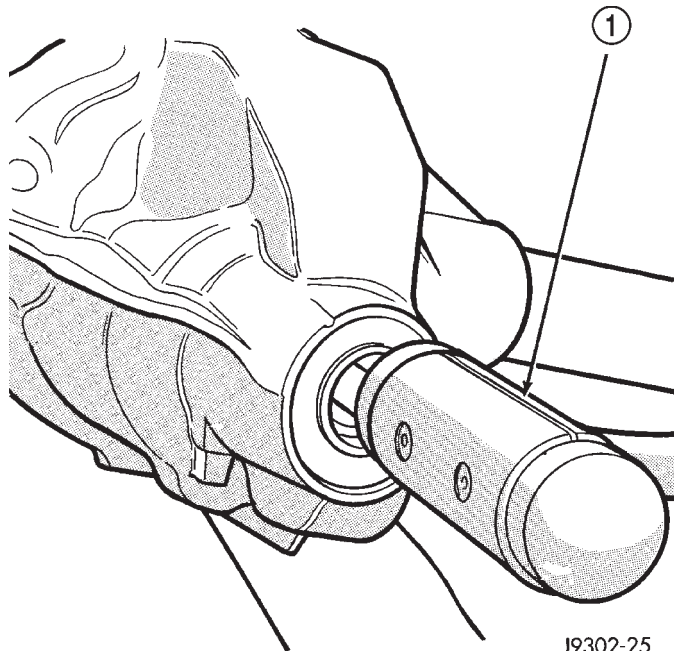

Fig. 43 Pinion Yoke Removal

- 1 - SPECIAL TOOL C-3281
- 2 - YOKE
- 3 - SPECIAL TOOL C-452

REMOVAL AND INSTALLATION (Continued)

(6) Remove the pinion gear from housing (Fig. 44). Catch the pinion with your hand to prevent it from falling and being damaged.



J9302-25

Fig. 44 Remove Pinion Gear

1 - RAWHIDE HAMMER

(7) Use Remover 7794-A and slide hammer to remove the pinion shaft seal (Fig. 45).

(8) Remove oil slinger, if equipped, and front pinion bearing.

(9) Remove the front pinion bearing cup with Remover C-4345 and Handle C-4171 (Fig. 46).

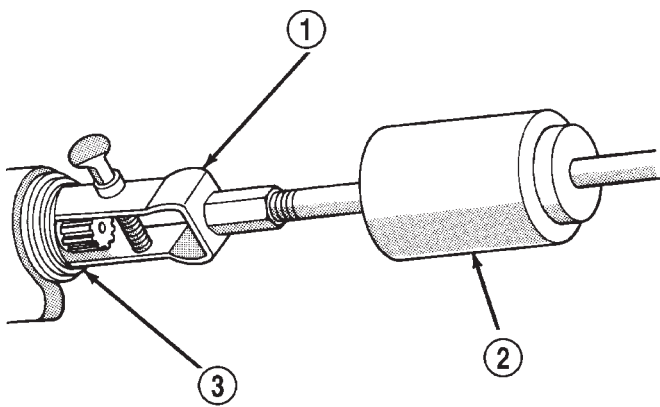

J9402-59X

Fig. 45 Seal Removal

1 - SPECIAL TOOL 7794A
 2 - SLIDE HAMMER
 3 - PINION SEAL

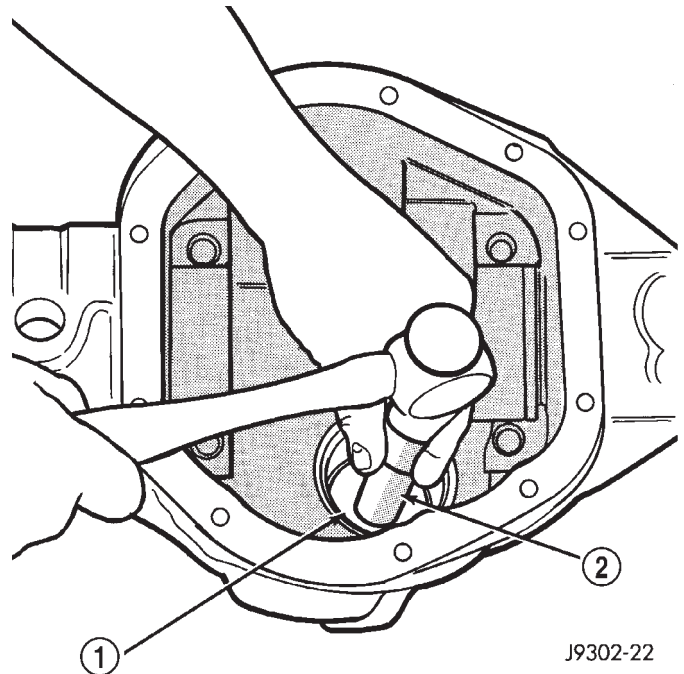

J9302-22

Fig. 46 Front Bearing Cup Removal

1 - REMOVER
 2 - HANDLE

(10) Remove the rear bearing cup from housing (Fig. 47). Use Remover D-149 and Handle C-4171.

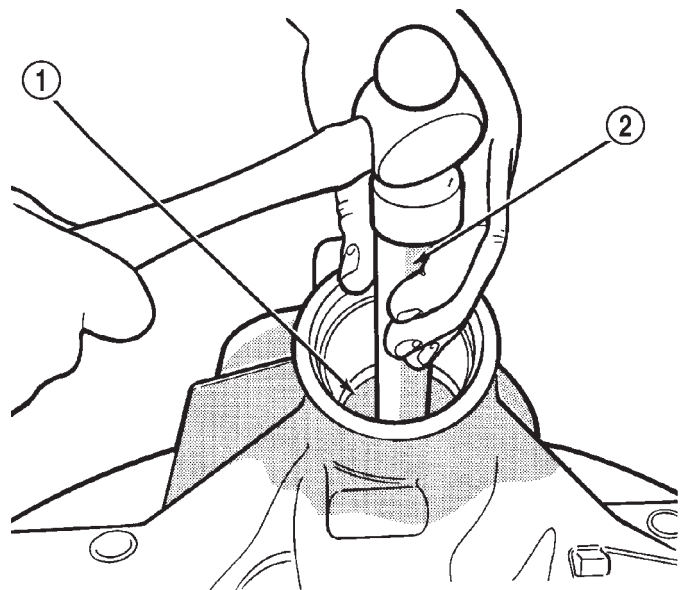

J9302-23

Fig. 47 Rear Bearing Cup Removal

1 - DRIVER
 2 - HANDLE

REMOVAL AND INSTALLATION (Continued)

(11) Remove the collapsible preload spacer (Fig. 48).

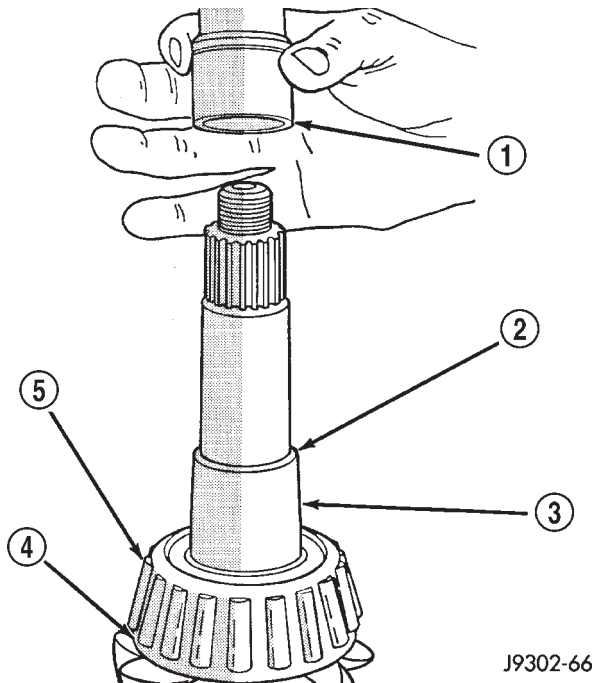

Fig. 48 Collapsible Spacer

- 1 - COLLAPSIBLE SPACER
- 2 - SHOULDER
- 3 - PINION GEAR
- 4 - OIL SLINGER
- 5 - REAR BEARING

(12) Remove the rear bearing from the pinion with Puller/Press C-293-PA and Adapters C-293-40 (Fig. 49).

Place 4 adapter blocks so they do not damage the bearing cage.

(13) Remove the depth shims from the pinion gear shaft. Record the thickness of the depth shims.

INSTALLATION

(1) Apply Mopar® Door Ease, or equivalent, stick lubricant to outside surface of bearing cup.

(2) Install the pinion rear bearing cup with Installer D-146 and Driver Handle C-4171 (Fig. 50). Ensure cup is correctly seated.

(3) Apply Mopar® Door Ease, or equivalent, stick lubricant to outside surface of bearing cup.

(4) Install the pinion front bearing cup with Installer D-130 and Handle C-4171 (Fig. 51).

(5) Install pinion front bearing, and oil slinger, if equipped.

(6) Apply a light coating of gear lubricant on the lip of pinion seal. Install seal with Installer C-3972-A and Handle C-4171 (Fig. 52).

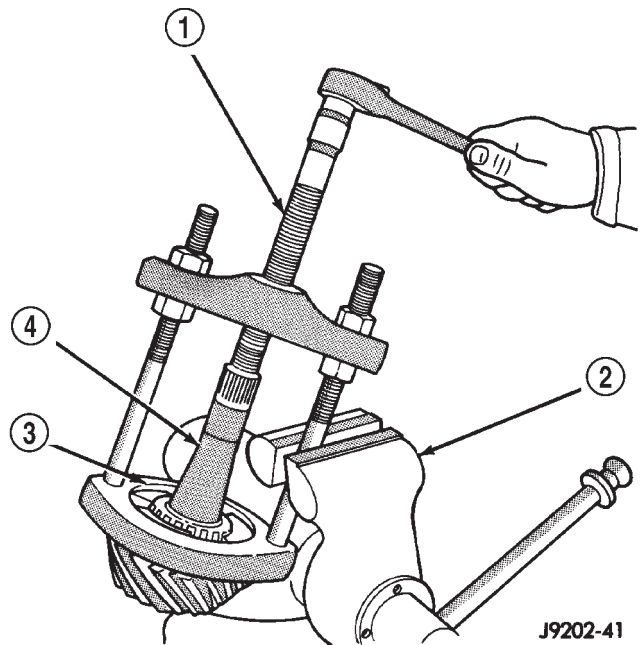

Fig. 49 Rear Bearing Removal

- 1 - SPECIAL TOOL C-293-PA
- 2 - VISE
- 3 - ADAPTERS
- 4 - DRIVE PINION GEAR SHAFT

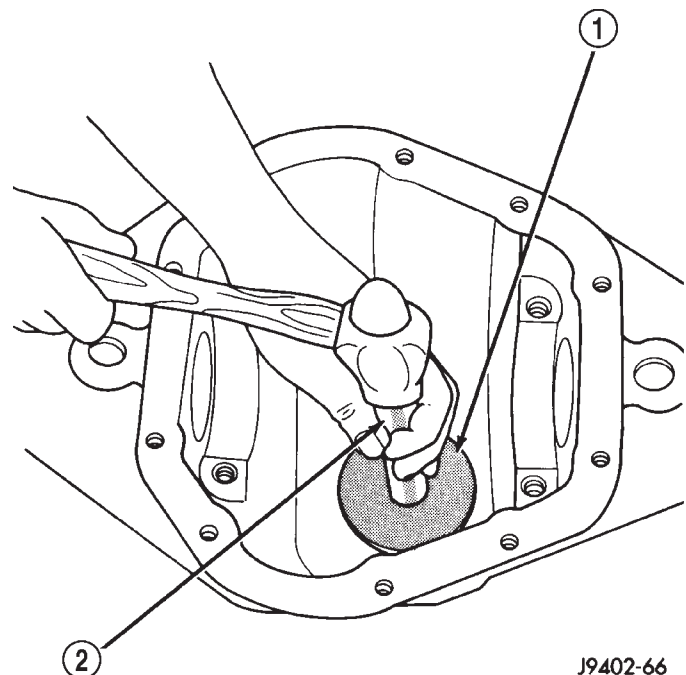
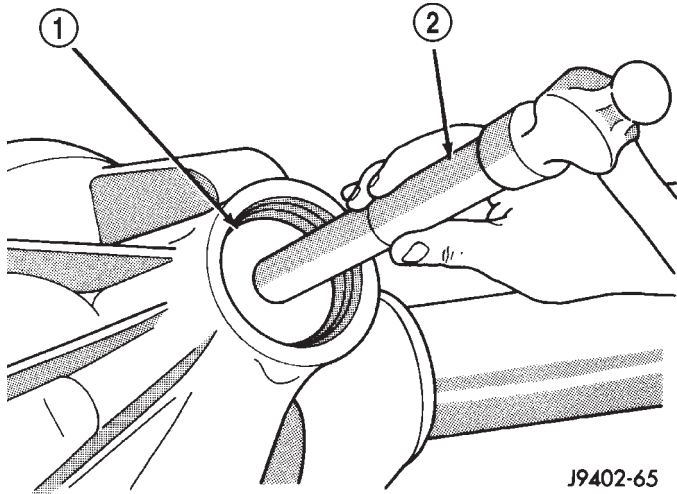

Fig. 50 Pinion Rear Bearing Cup Installation

- 1 - INSTALLER
- 2 - HANDLE

REMOVAL AND INSTALLATION (Continued)



J9402-65

Fig. 51 Pinion Front Bearing Cup Installation

- 1 - INSTALLER
- 2 - HANDLE

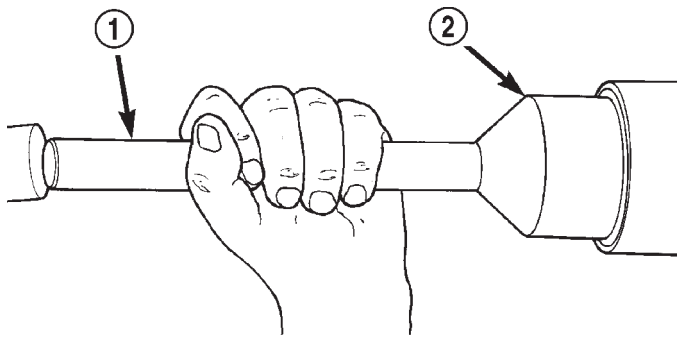

80a7e2be

Fig. 52 Pinion Seal Installation

- 1 - SPECIAL TOOL C-4171
- 2 - SPECIAL TOOL C-3972-A

NOTE: Pinion depth shims are placed between the rear pinion bearing cone and pinion gear to achieve proper ring and pinion gear mesh. If the factory installed ring and pinion gears are reused, the pinion depth shim should not require replacement. If required, refer to Pinion Gear Depth to select the proper thickness shim before installing rear pinion bearing.

(7) Place the proper thickness depth shim on the pinion gear.

(8) Install the rear bearing and slinger, if equipped, on the pinion gear with Installer W-262 (Fig. 53).

(9) Install a new collapsible preload spacer on pinion shaft and install pinion gear in housing (Fig. 54).

(10) Install pinion gear in housing.

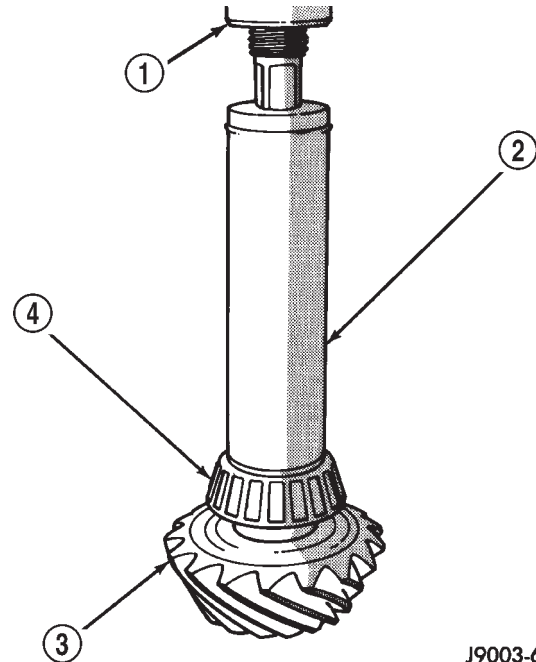

J9003-67

Fig. 53 Shaft Rear Bearing Installation

- 1 - PRESS
- 2 - INSTALLATION TOOL
- 3 - DRIVE PINION GEAR
- 4 - DRIVE PINION GEAR SHAFT REAR BEARING

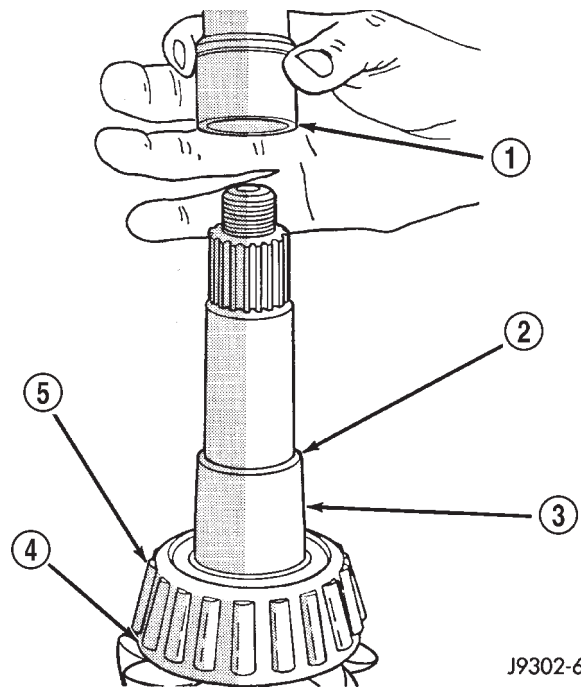

J9302-66

Fig. 54 Collapsible Preload Spacer

- 1 - COLLAPSIBLE SPACER
- 2 - SHOULDER
- 3 - PINION GEAR
- 4 - OIL SLINGER
- 5 - REAR BEARING

REMOVAL AND INSTALLATION (Continued)

(11) Install yoke with Installer Screw 8112, Cup 8109, and holder 6958 (Fig. 55).

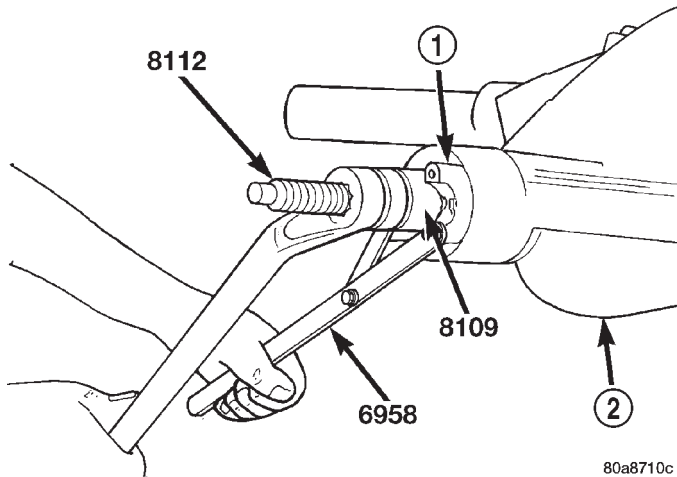

Fig. 55 Pinion Yoke Installation

- 1 - PINION YOKE
2 - AXLE HOUSING

(12) Install the yoke washer and a new nut on the pinion gear and tighten the pinion nut until there is zero bearing end-play.

(13) Tighten the nut to 271 N·m (200 ft. lbs.).

CAUTION: Never loosen pinion gear nut to decrease pinion gear bearing rotating torque and never exceed specified preload torque. If preload torque or rotating torque is exceeded a new collapsible spacer must be installed. The torque sequence will then have to be repeated.

(14) Using yoke holder 6958, a short length of 1 in. pipe, and a torque wrench set at 474 N·m (350 ft. lbs.), crush collapsible spacer until bearing end play is taken up (Fig. 56).

NOTE: If the spacer requires more than 474 N·m (350 ft. lbs.) torque to crush, the collapsible spacer is defective and must be replaced.

(15) Slowly tighten the nut in 6.8 N·m (5 ft. lbs.) increments until the required rotating torque is achieved. Measure the rotating torque frequently to avoid over crushing the collapsible spacer (Fig. 57).

(16) Rotate the pinion a minimum of ten times. Verify that the pinion rotates smoothly. Check bearing rotating torque with an inch pound torque wrench (Fig. 57). The torque necessary to rotate the pinion gear should be:

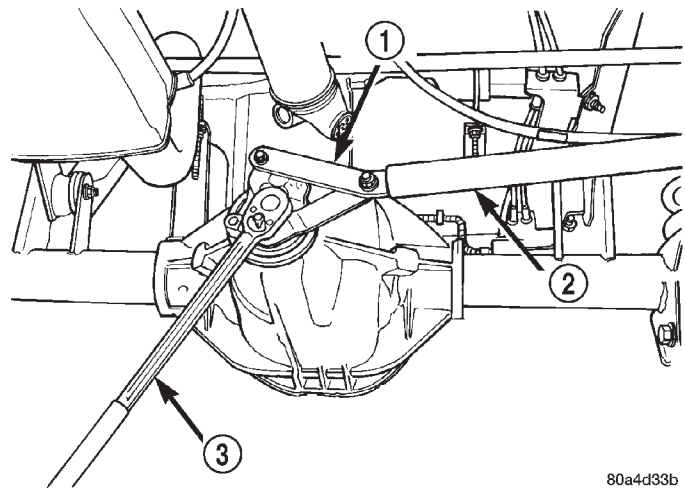

Fig. 56 Tightening Pinion Nut

- 1 - SPECIAL TOOL 6958
2 - 1 in. PIPE
3 - 3/4 DRIVE TORQUE WRENCH

- Original Bearings — 1 to 2.25 N·m (10 to 20 in. lbs.).
- New Bearings — 1.7 to 3.4 N·m (15 to 30 in. lbs.).

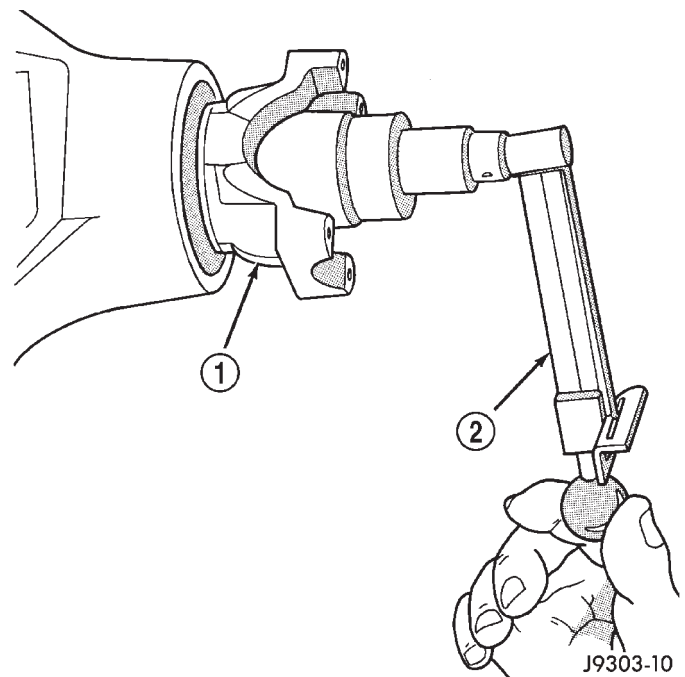

Fig. 57 Check Pinion Gear Rotating Torque

- 1 - PINION YOKE
2 - INCH POUND TORQUE WRENCH

(17) Install differential in housing.

REMOVAL AND INSTALLATION (Continued)

FINAL ASSEMBLY

(1) Scrape the residual sealant from the housing and cover mating surfaces. Clean the mating surfaces with mineral spirits. Apply a bead of Mopar® Silicone Rubber Sealant, or equivalent, on the housing cover (Fig. 58).

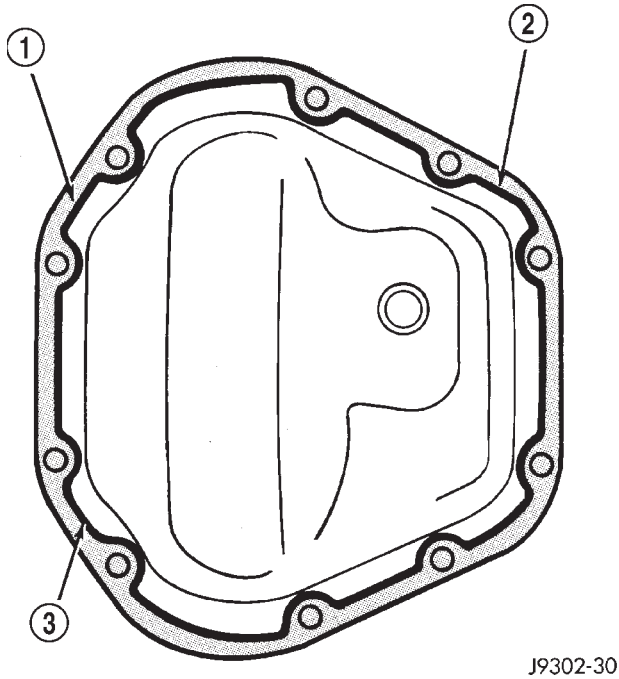

J9302-30

Fig. 58 Typical Housing Cover With Sealant

- 1 - SEALING SURFACE
- 2 - CONTOUR OF BEAD
- 3 - BEAD THICKNESS 6.35MM (1/4")

Install the housing cover within 5 minutes after applying the sealant.

(2) Install the cover on the differential with the attaching bolts. Install the identification tag. Tighten the cover bolts to 41 N·m (30 ft. lbs.) torque.

CAUTION: Overfilling the differential can result in lubricant foaming and overheating.

(3) Refill the differential housing with gear lubricant. Refer to the Lubricant Specifications section of this group for the gear lubricant requirements.

(4) Install the fill hole plug.

DISASSEMBLY AND ASSEMBLY

STANDARD DIFFERENTIAL

DISASSEMBLY

- (1) Remove pinion mate shaft lock screw (Fig. 59).
- (2) Remove pinion mate shaft.

(3) Rotate the differential side gears and remove the differential pinion gears and thrust washers (Fig. 60).

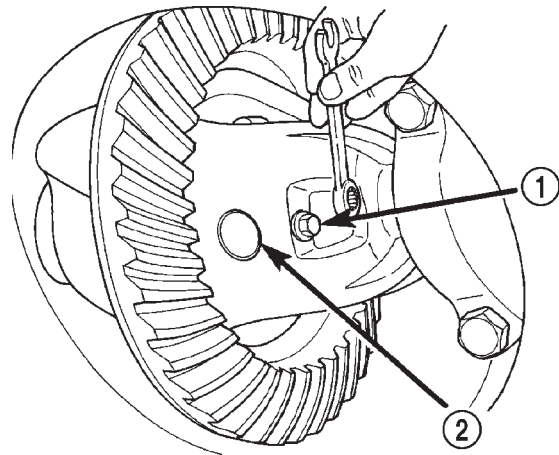

80be4604

Fig. 59 Pinion Mate Shaft Lock Screw

- 1 - LOCK SCREW
- 2 - PINION MATE SHAFT

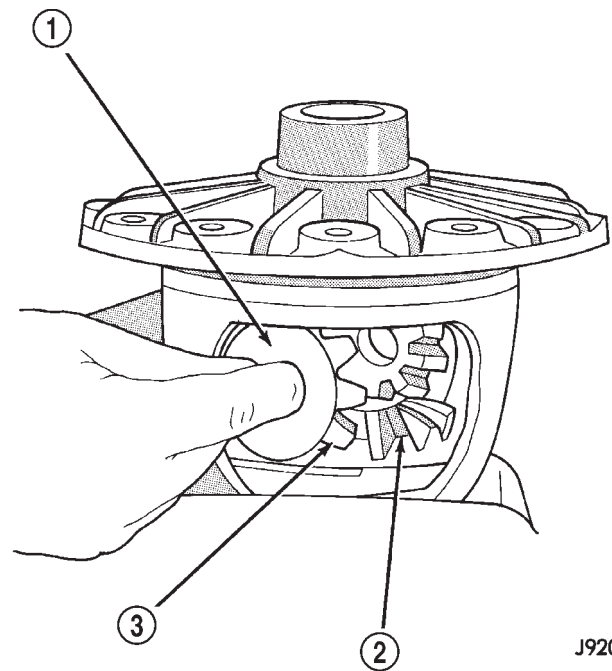

J9203-61

Fig. 60 Pinion Mate Gear Removal

- 1 - THRUST WASHER
- 2 - SIDE GEAR
- 3 - PINION MATE GEAR

(4) Remove the differential side gears and thrust washers.

ASSEMBLY

(1) Install the differential side gears and thrust washers.

DISASSEMBLY AND ASSEMBLY (Continued)

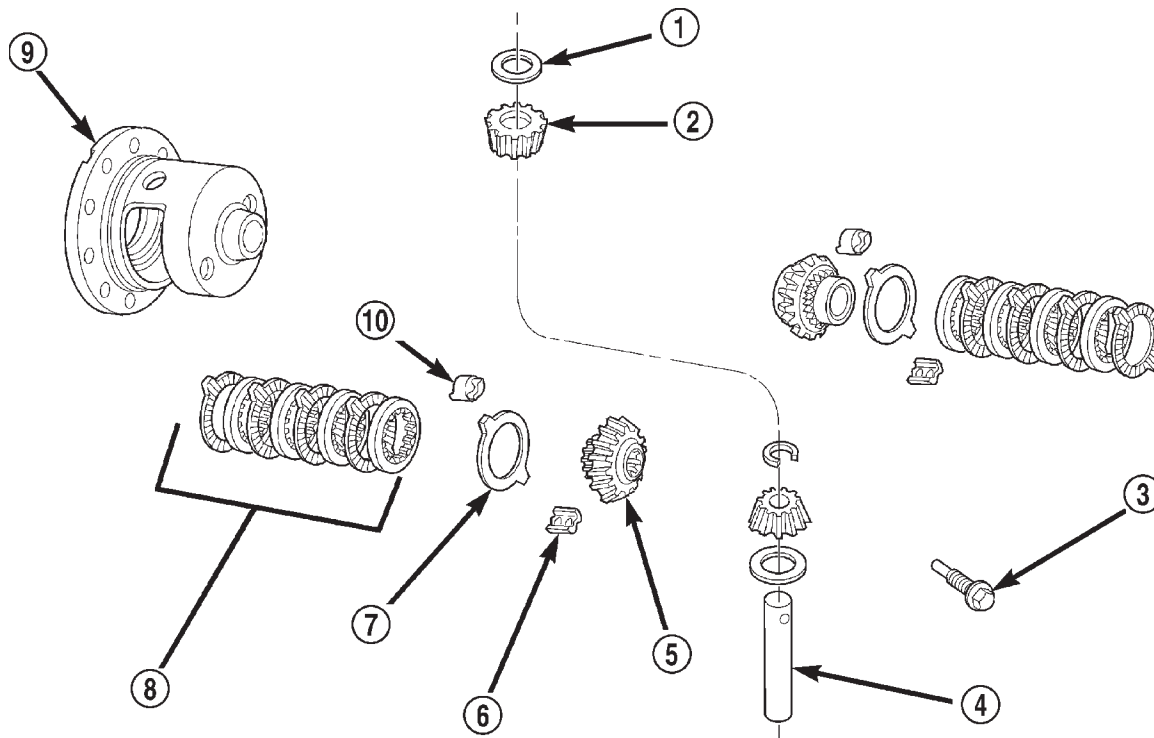

80a77404

Fig. 61 Trac-lok™ Differential Components

- | | |
|-----------------------|-----------------------|
| 1 - THRUST WASHER | 6 - RETAINER |
| 2 - PINION | 7 - DISC |
| 3 - SHAFT LOCK SCREW | 8 - CLUTCH PACK |
| 4 - PINION MATE SHAFT | 9 - DIFFERENTIAL CASE |
| 5 - SIDE GEAR | 10 - RETAINER |

(2) Install the differential pinion gears and thrust washers.

(3) Install the pinion mate shaft.

(4) Align the hole in the pinion mate shaft with the hole in the differential case and install the pinion mate shaft lock screw.

(5) Lubricate all differential components with hypoid gear lubricant.

TRAC-LOK™ DIFFERENTIAL

The Trac-lok™ differential components are illustrated in (Fig. 61). Refer to this illustration during repair service.

DISASSEMBLY

(1) Clamp Side Gear Holding Tool 6965 in a vise.

(2) Position the differential case on Side Gear Holding Tool 6965 (Fig. 62).

(3) Remove ring gear, if necessary. Ring gear removal is necessary only if the ring gear is to be replaced. The Trac-lok™ differential can be serviced with the ring gear installed.

(4) Remove the pinion gear mate shaft lock screw (Fig. 63).

(5) Remove the pinion gear mate shaft. If necessary, use a drift and hammer (Fig. 64).

(6) Install and lubricate Step Plate C-6960-3 (Fig. 65).

DISASSEMBLY AND ASSEMBLY (Continued)

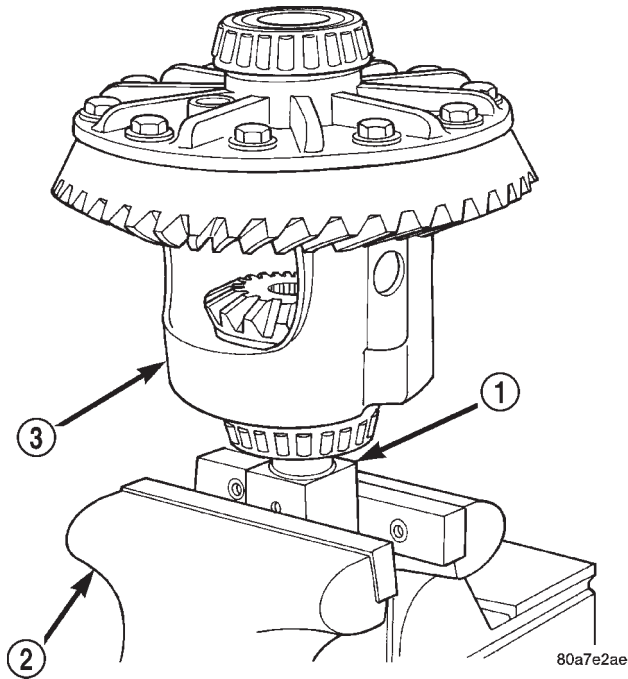

80a7e2ae

Fig. 62 Differential Case Holding Tool

- 1 - SPECIAL TOOL 6965
- 2 - VISE
- 3 - DIFFERENTIAL

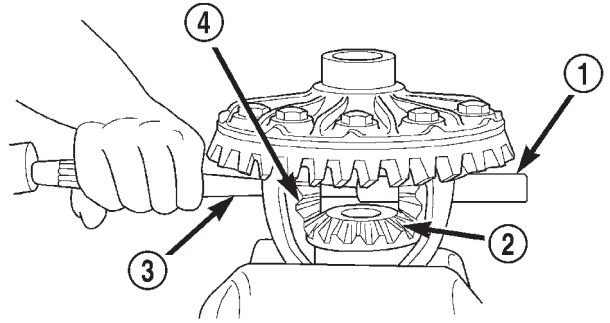

80a773e1

Fig. 64 Mate Shaft Removal

- 1 - PINION MATE SHAFT
- 2 - SIDE GEAR
- 3 - DRIFT
- 4 - PINION MATE GEAR

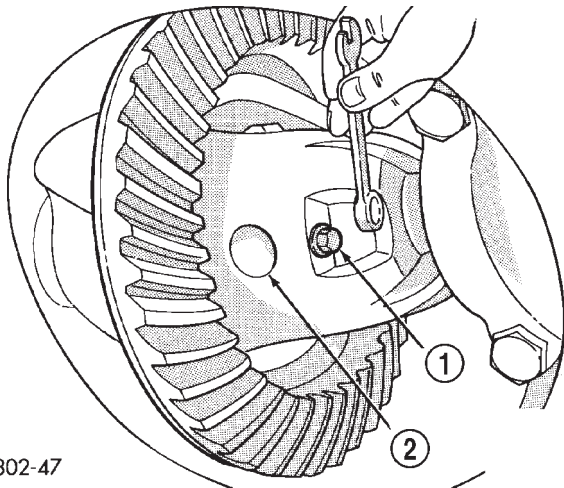

J9302-47

Fig. 63 Mate Shaft Lock Screw

- 1 - LOCK SCREW
- 2 - PINION GEAR MATE SHAFT

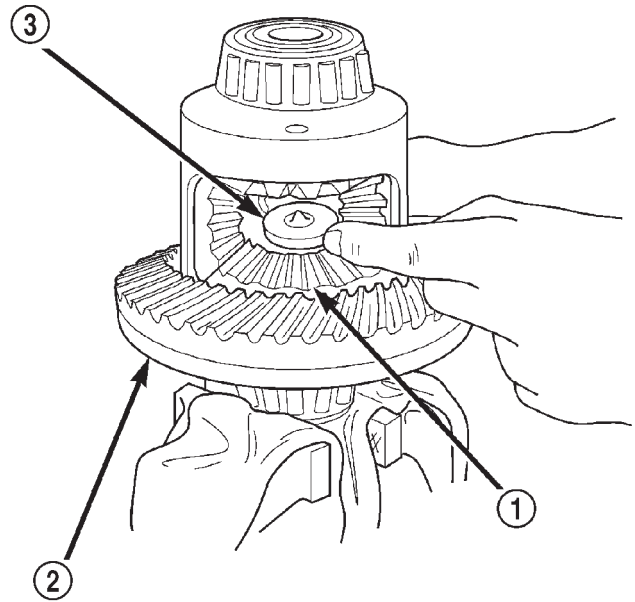

80a83886

Fig. 65 Step Plate Tool Installation

- 1 - LOWER SIDE GEAR
- 2 - DIFFERENTIAL CASE
- 3 - SPECIAL TOOL C-6960-3

DISASSEMBLY AND ASSEMBLY (Continued)

(7) Assemble Threaded Adapter C-6960-1 into top side gear. Thread Forcing Screw C-6960-4 into adapter until it becomes centered in adapter plate.

(8) Position a small screw driver in slot of Threaded Adapter C-6960-1 (Fig. 66) to prevent adapter from turning.

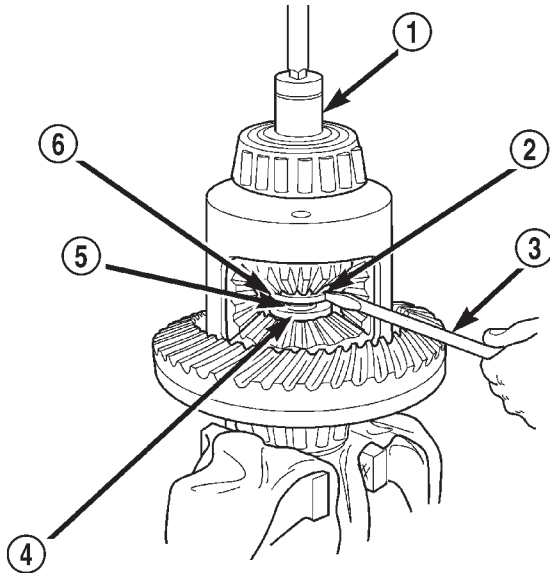

80a8387f

Fig. 66 Threaded Adapter Installation

- 1 - SOCKET
- 2 - SLOT IN ADAPTER
- 3 - SCREWDRIVER
- 4 - DISC C-6960-3
- 5 - THREADED ROD C-6960-4
- 6 - THREADED ADAPTER DISC C-6960-1

(9) Tighten forcing screw tool 122 N·m (90 ft. lbs.) maximum to compress Belleville springs in clutch packs (Fig. 67).

(10) Using an appropriate size feeler gauge, remove thrust washers from behind the pinion gears (Fig. 68).

(11) Insert Turning Bar C-6960-2 in case (Fig. 69).

(12) Loosen the Forcing Screw C-6960-4 in small increments until the clutch pack tension is relieved and the differential case can be turned using Turning Bar C-6960-2.

(13) Rotate differential case until the pinion gears can be removed.

(14) Remove pinion gears from differential case.

(15) Remove Forcing Screw C-6960-4, Step Plate C-6960-3, and Threaded Adapter C-6960-1.

(16) Remove top side gear, clutch pack retainer, and clutch pack. Keep plates in correct order during removal (Fig. 70).

(17) Remove differential case from Side Gear Holding Tool 6965. Remove side gear, clutch pack retainer,

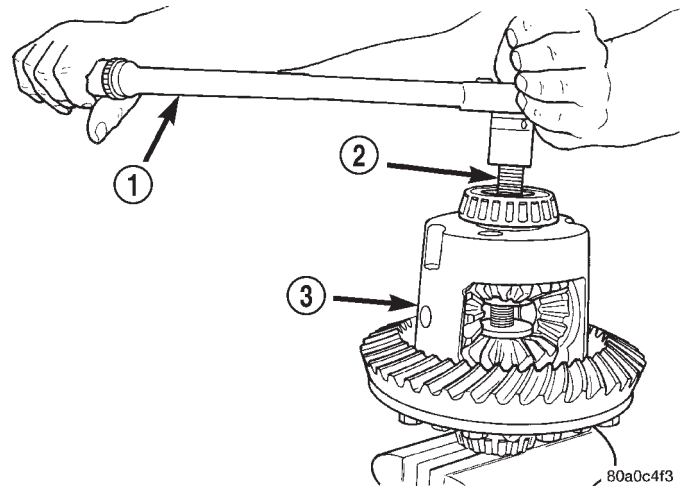

80a0c4f3

Fig. 67 Tighten Belleville Spring Compressor Tool

- 1 - TORQUE WRENCH
- 2 - TOOL ASSEMBLED
- 3 - DIFFERENTIAL CASE

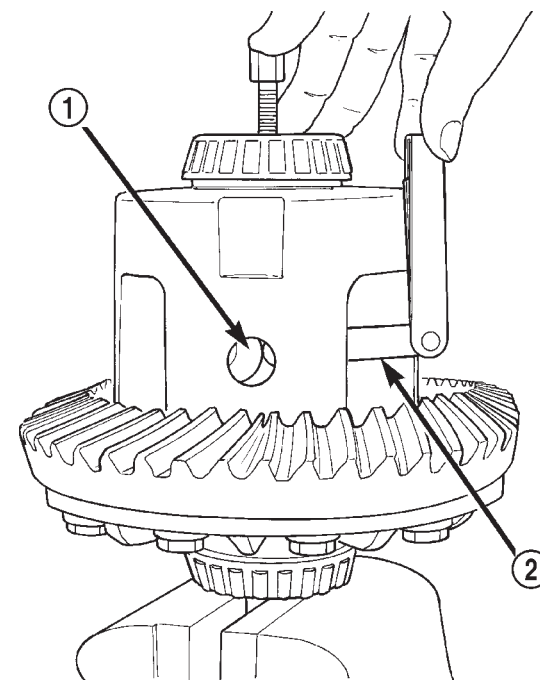

80a77406

Fig. 68 Remove Pinion Gear Thrust Washer

- 1 - THRUST WASHER
- 2 - FEELER GAUGE

and clutch pack. Keep plates in correct order during removal.

ASSEMBLY

NOTE: The clutch discs are replaceable as complete sets only. If one clutch disc pack is damaged, both packs must be replaced.

DISASSEMBLY AND ASSEMBLY (Continued)

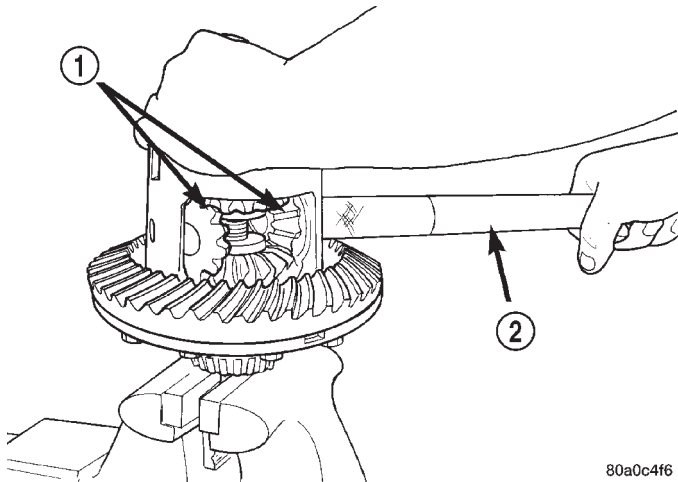

80a0c4f6

Fig. 69 Pinion Gear Removal

- 1 - PINION GEARS
- 2 - TOOL

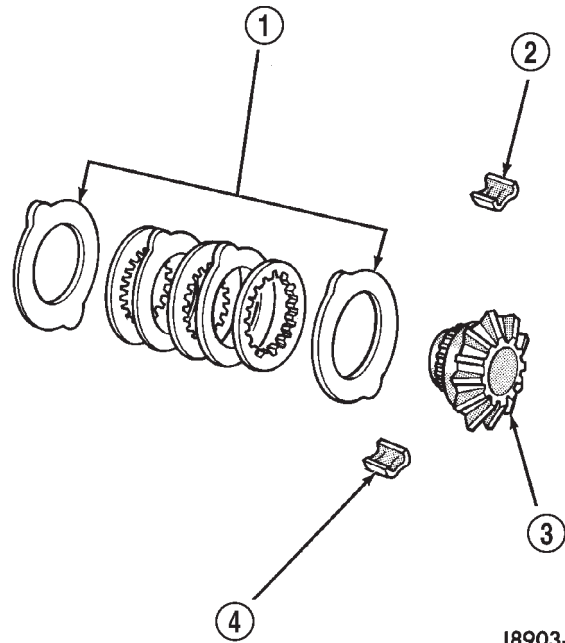

J8903-50

Fig. 71 Clutch Disc Pack

- 1 - CLUTCH PACK
- 2 - RETAINER
- 3 - SIDE GEAR
- 4 - RETAINER

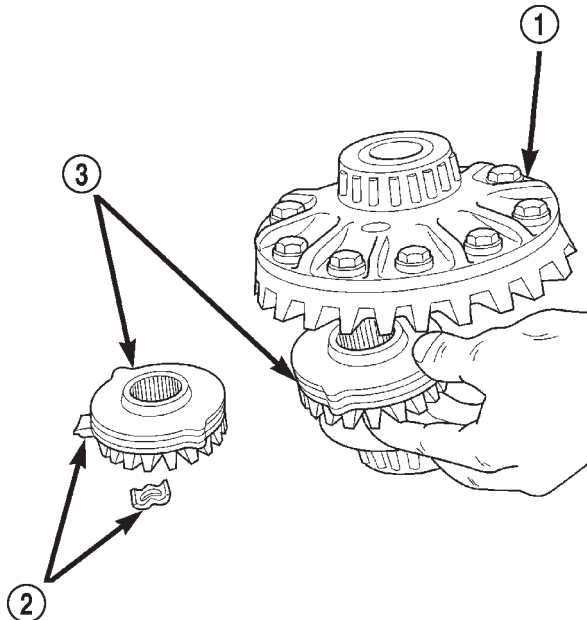

80a98382

Fig. 70 Side Gear & Clutch Disc Removal

- 1 - DIFFERENTIAL CASE
- 2 - RETAINER
- 3 - SIDE GEAR AND CLUTCH DISC PACK

Lubricate each component with gear lubricant before assembly.

(1) Assemble the clutch discs into packs and secure disc packs with retaining clips (Fig. 71).

(2) Position assembled clutch disc packs on the side gear hubs.

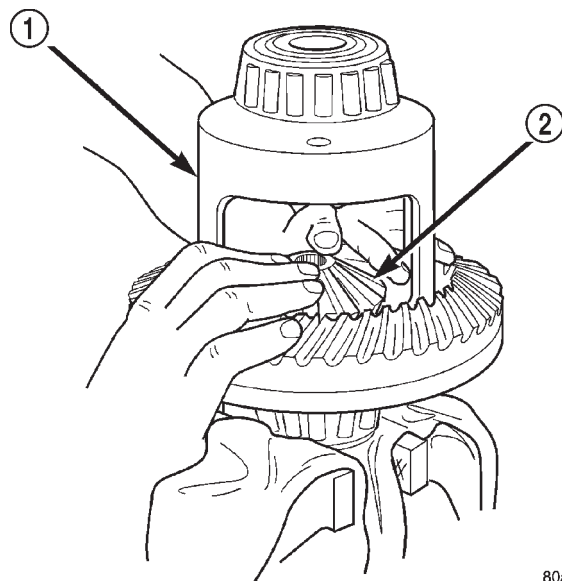

80a7739c

Fig. 72 Clutch Discs & Lower Side Gear Installation

- 1 - DIFFERENTIAL CASE
- 2 - LOWER SIDE GEAR AND CLUTCH DISC PACK

DISASSEMBLY AND ASSEMBLY (Continued)

(4) Position the differential case on Side Gear Holding Tool 6965.

(5) Install lubricated Step Plate C-6960-3 in lower side gear (Fig. 73).

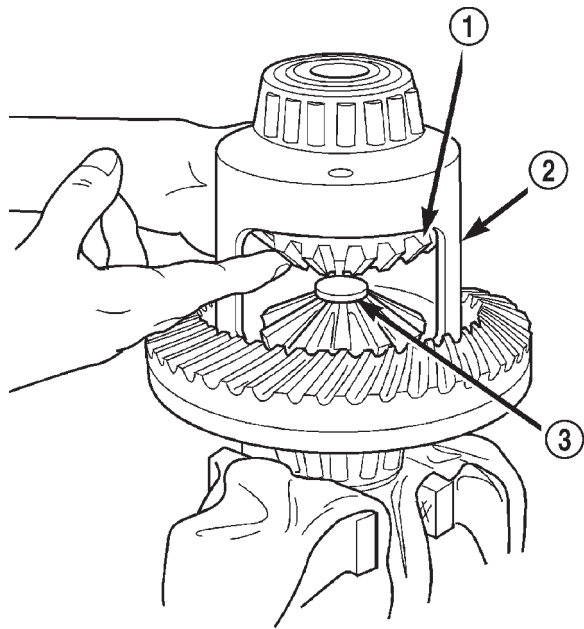

80a83887

Fig. 73 Upper Side Gear & Clutch Disc Pack Installation

- 1 - UPPER SIDE GEAR AND CLUTCH DISC PACK
 2 - DIFFERENTIAL CASE
 3 - SPECIAL TOOL C-6960-3

(6) Install the upper side gear and clutch disc pack (Fig. 73).

(7) Hold assembly in position. Insert Threaded Adapter C-6960-1 into top side gear.

(8) Insert Forcing Screw C-6960-4.

(9) Tighten forcing screw tool to slightly compress clutch discs.

(10) Place pinion gears in position in side gears and verify that the pinion mate shaft hole is aligned.

(11) Rotate case with Turning Bar C-6960-2 until the pinion mate shaft holes in pinion gears align with holes in case. It may be necessary to slightly tighten the forcing screw in order to install the pinion gears.

(12) Tighten forcing screw to 122 N·m (90 ft. lbs.) maximum to compress the Belleville springs.

(13) Lubricate and install thrust washers behind pinion gears and align washers with a small screw driver. Insert mate shaft into each pinion gear to verify alignment.

(14) Remove Forcing Screw C-6960-4, Step Plate C-6960-3, and Threaded Adapter C-6960-1.

(15) Install pinion gear mate shaft and align holes in shaft and case.

(16) Install the pinion mate shaft lock screw finger tight to hold shaft during differential installation.

If replacement gears and thrust washers were installed, it is not necessary to measure the gear backlash. Correct fit is due to close machining tolerances during manufacture.

(17) Lubricate all differential components with hypoid gear lubricant.

CLEANING AND INSPECTION

AXLE COMPONENTS

Wash differential components with cleaning solvent and dry with compressed air. **Do not steam clean the differential components.**

Wash bearings with solvent and towel dry, or dry with compressed air. **DO NOT** spin bearings with compressed air. **Cup and bearing must be replaced as matched sets only.**

Clean axle shaft tubes and oil channels in housing. Inspect for;

- Smooth appearance with no broken/dented surfaces on the bearing rollers or the roller contact surfaces.

- Bearing cups must not be distorted or cracked.

- Machined surfaces should be smooth and without any raised edges.

- Raised metal on shoulders of cup bores should be removed with a hand stone.

- Wear and damage to pinion gear mate shaft, pinion gears, side gears and thrust washers. Replace as a matched set only.

- Ring and pinion gear for worn and chipped teeth.

- Ring gear for damaged bolt threads. Replaced as a matched set only.

- Pinion yoke for cracks, worn splines, pitted areas, and a rough/corroded seal contact surface. Repair or replace as necessary.

- Preload shims for damage and distortion. Install new shims, if necessary.

TRAC-LOK™

Clean all components in cleaning solvent. Dry components with compressed air. Inspect clutch pack plates for wear, scoring or damage. Replace both clutch packs if any one component in either pack is damaged. Inspect side gears and pinions. Replace any gear that is worn, cracked, chipped or damaged. Inspect differential case and pinion shaft. Replace if worn or damaged.

CLEANING AND INSPECTION (Continued)

PRESOAK PLATES AND DISC

Plates and discs with fiber coating (no grooves or lines) must be presoaked in Friction Modifier before assembly. Soak plates and discs for a minimum of 20 minutes.

ADJUSTMENTS

PINION GEAR DEPTH

GENERAL INFORMATION

Ring and pinion gears are supplied as matched sets only. The identifying numbers for the ring and pinion gear are etched into the face of each gear (Fig. 74). A plus (+) number, minus (-) number or zero (0) is etched into the face of the pinion gear. This number is the amount (in thousandths of an inch) the depth varies from the standard depth setting of a pinion etched with a (0). The standard setting from the center line of the ring gear to the back face of the pinion is 96.850 mm (3.813 in.). The standard depth provides the best teeth contact pattern. Refer to Backlash and Contact Pattern Analysis Paragraph in this section for additional information.

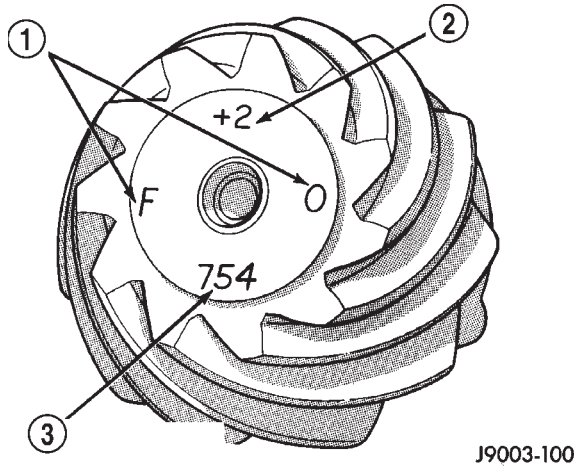
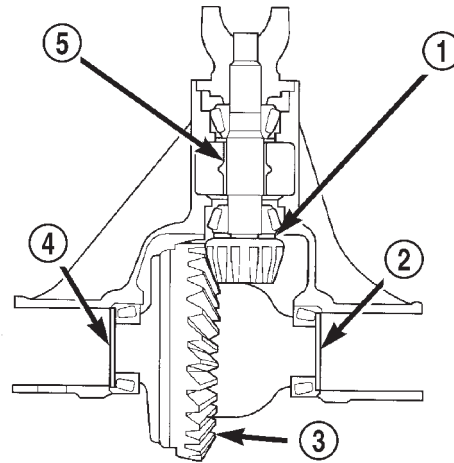

Fig. 74 Pinion Gear ID Numbers

- 1 - PRODUCTION NUMBERS
- 2 - DRIVE PINION GEAR DEPTH VARIANCE
- 3 - GEAR MATCHING NUMBER (SAME AS RING GEAR NUMBER)

Compensation for pinion depth variance is achieved with select shims. The shims are placed under the inner pinion bearing cone (Fig. 75).

If a new gear set is being installed, note the depth variance etched into both the original and replacement pinion gear. Add or subtract the thickness of the original depth shims to compensate for the difference in the depth variances. Refer to the Depth Variance charts.



80a5037a

Fig. 75 Shim Locations

- 1 - PINION GEAR DEPTH SHIM
- 2 - DIFFERENTIAL BEARING SHIM-PINION GEAR SIDE
- 3 - RING GEAR
- 4 - DIFFERENTIAL BEARING SHIM-RING GEAR SIDE
- 5 - COLLAPSIBLE SPACER

Note where Old and New Pinion Marking columns intersect. Intersecting figure represents plus or minus amount needed.

Note the etched number on the face of the drive pinion gear (-1, -2, 0, +1, +2, etc.). The numbers represent thousands of an inch deviation from the standard. If the number is negative, add that value to the required thickness of the depth shim(s). If the number is positive, subtract that value from the thickness of the depth shim(s). If the number is 0 no change is necessary. Refer to the Pinion Gear Depth Variance Chart.

PINION DEPTH MEASUREMENT AND ADJUSTMENT

Measurements are taken with pinion cups and pinion bearings installed in housing. Take measurements with a Pinion Gauge Set, Pinion Block 6735, Arbor Discs 6732, and Dial Indicator C-3339 (Fig. 76).

(1) Assemble Pinion Height Block 6739, Pinion Block 6735, and rear pinion bearing onto Screw 6741 (Fig. 76).

(2) Insert assembled height gauge components, rear bearing and screw into axle housing through pinion bearing cups (Fig. 77).

(3) Install front pinion bearing and Cone 6740 hand tight (Fig. 76).

(4) Place Arbor Disc 6732 on Arbor D-115-3 in position in axle housing side bearing cradles (Fig. 78). Install differential bearing caps on Arbor Discs and tighten cap bolts. Refer to the Torque Specifications in this section.

ADJUSTMENTS (Continued)

PINION GEAR DEPTH VARIANCE

Original Pinion Gear Depth Variance	Replacement Pinion Gear Depth Variance								
	-4	-3	-2	-1	0	+1	+2	+3	+4
+4	+0.008	+0.007	+0.006	+0.005	+0.004	+0.003	+0.002	+0.001	0
+3	+0.007	+0.006	+0.005	+0.004	+0.003	+0.002	+0.001	0	-0.001
+2	+0.006	+0.005	+0.004	+0.003	+0.002	+0.001	0	-0.001	-0.002
+1	+0.005	+0.004	+0.003	+0.002	+0.001	0	-0.001	-0.002	-0.003
0	+0.004	+0.003	+0.002	+0.001	0	-0.001	-0.002	-0.003	-0.004
-1	+0.003	+0.002	+0.001	0	-0.001	-0.002	-0.003	-0.004	-0.005
-2	+0.002	+0.001	0	-0.001	-0.002	-0.003	-0.004	-0.005	-0.006
-3	+0.001	0	-0.001	-0.002	-0.003	-0.004	-0.005	-0.006	-0.007
-4	0	-0.001	-0.002	-0.003	-0.004	-0.005	-0.006	-0.007	-0.008

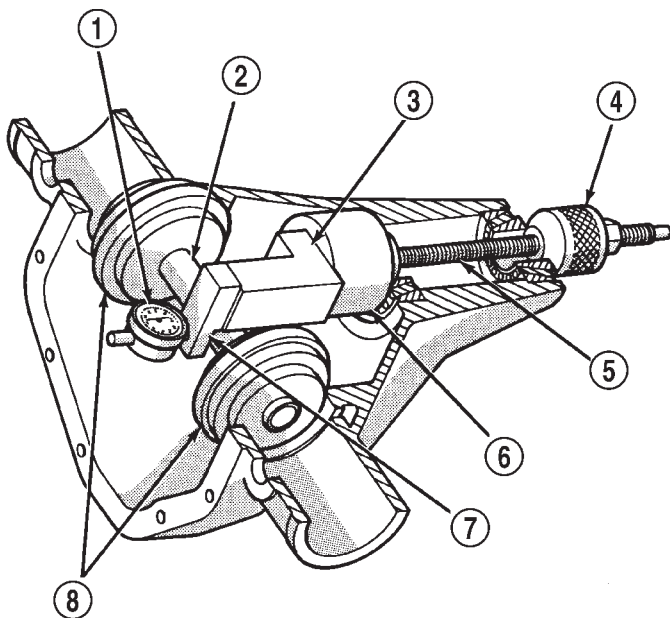

J9403-45

Fig. 76 Pinion Gear Depth Gauge Tools—Typical

- 1 - DIAL INDICATOR
- 2 - ARBOR
- 3 - PINION HEIGHT BLOCK
- 4 - CONE
- 5 - SCREW
- 6 - PINION BLOCK
- 7 - SCOOTER BLOCK
- 8 - ARBOR DISC

NOTE: Arbor Discs 6732 have different step diameters to fit other axle sizes. Pick correct size step for axle being serviced.

(5) Assemble Dial Indicator C-3339 into Scooter Block D-115-2 and secure set screw.

(6) Place Scooter Block/Dial Indicator in position in axle housing so dial probe and scooter block are

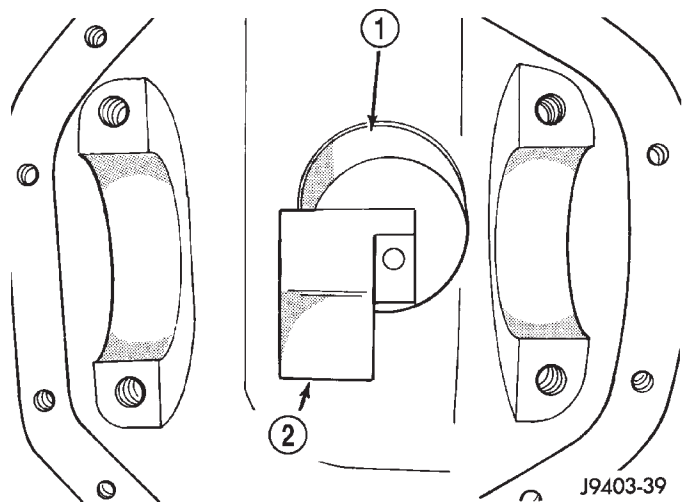

J9403-39

Fig. 77 Pinion Height Block—Typical

- 1 - PINION BLOCK
- 2 - PINION HEIGHT BLOCK

flush against the surface of the pinion height block. Hold scooter block in place and zero the dial indicator face to the pointer. Tighten dial indicator face lock screw.

(7) With scooter block still in position against the pinion height block, slowly slide the dial indicator probe over the edge of the pinion height block. Observe how many revolutions counterclockwise the dial pointer travels (approximately 0.125 in.) to the out-stop of the dial indicator.

(8) Slide the dial indicator probe across the gap between the pinion height block and the arbor bar with the scooter block against the pinion height block (Fig. 79). When the dial probe contacts the arbor bar, the dial pointer will turn clockwise. Bring dial pointer back to zero against the arbor bar, do not turn dial face. Continue moving the dial probe to the crest of the arbor bar and record the highest reading. If the dial indicator can not achieve the zero reading,

ADJUSTMENTS (Continued)

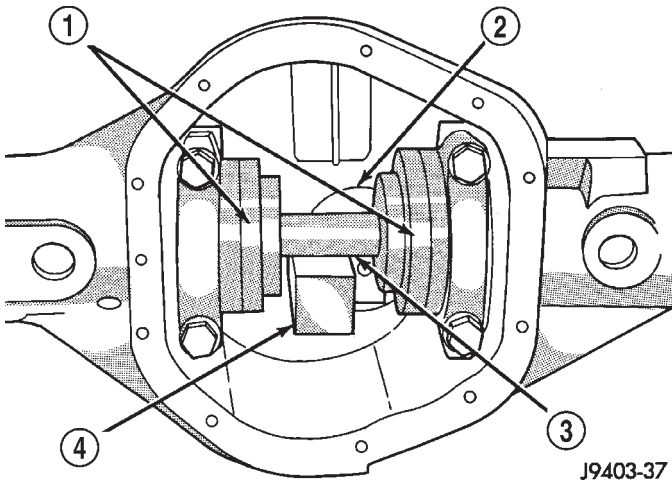

J9403-37

Fig. 78 Gauge Tools In Housing—Typical

- 1 - ARBOR DISC
- 2 - PINION BLOCK
- 3 - ARBOR
- 4 - PINION HEIGHT BLOCK

the rear bearing cup or the pinion depth gauge set is not installed correctly.

(9) Select a shim equal to the dial indicator reading plus the drive pinion gear depth variance number etched in the face of the pinion gear (Fig. 74) using the opposite sign on the variance number. For example, if the depth variance is -2, add +0.002 in. to the dial indicator reading.

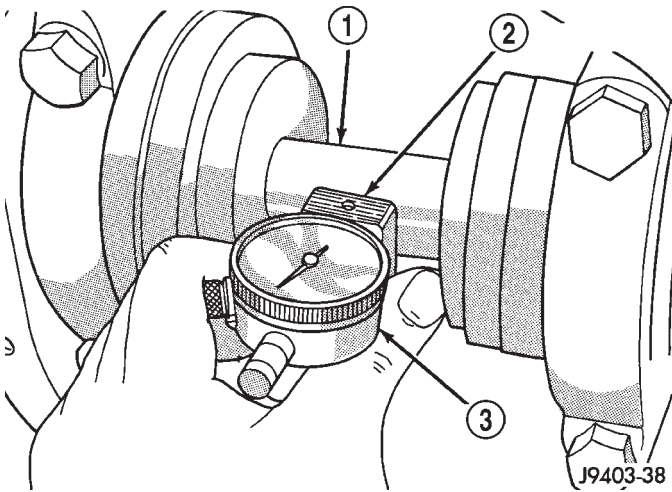

J9403-38

Fig. 79 Pinion Gear Depth Measurement—Typical

- 1 - ARBOR
- 2 - SCOOTER BLOCK
- 3 - DIAL INDICATOR

(10) Remove the pinion depth gauge components from the axle housing

DIFFERENTIAL BEARING PRELOAD AND GEAR BACKLASH

Differential side bearing preload and gear backlash is achieved by selective shims inserted between the bearing cup and the axle housing. The proper shim thickness can be determined using slip-fit dummy bearings D-348 in place of the differential side bearings and a dial indicator C-3339. Before proceeding with the differential bearing preload and gear backlash measurements, measure the pinion gear depth and prepare the pinion gear for installation. Establishing proper pinion gear depth is essential to establishing gear backlash and tooth contact patterns. After the overall shim thickness to take up differential side play is measured, the pinion gear is installed, and the gear backlash shim thickness is measured. The overall shim thickness is the total of the dial indicator reading, starting point shim thickness, and the preload specification added together. The gear backlash measurement determines the thickness of the shim used on the ring gear side of the differential case. Subtract the gear backlash shim thickness from the total overall shim thickness and select that amount for the pinion gear side of the differential (Fig. 80).

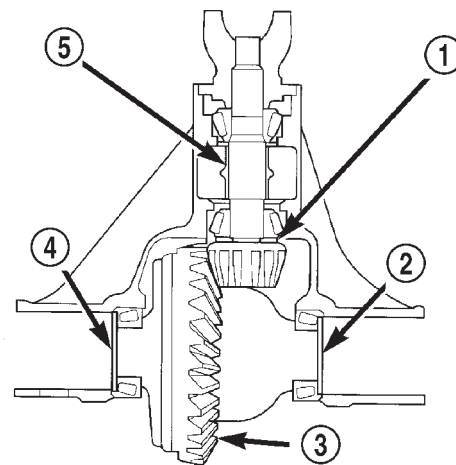

80a5037a

Fig. 80 Axle Adjustment Shim Locations

- 1 - PINION GEAR DEPTH SHIM
- 2 - DIFFERENTIAL BEARING SHIM-PINION GEAR SIDE
- 3 - RING GEAR
- 4 - DIFFERENTIAL BEARING SHIM-RING GEAR SIDE
- 5 - COLLAPSIBLE SPACER

ADJUSTMENTS (Continued)

SHIM SELECTION

NOTE: It is difficult to salvage the differential side bearings during the removal procedure. Install replacement bearings if necessary.

- (1) Remove side bearings from differential case.
- (2) Install ring gear, if necessary, on differential case and tighten bolts to specification.
- (3) Install dummy side bearings D-348 on differential case.
- (4) Install differential case in axle housing.
- (5) Measure and record the thickness of Dummy Shims 8107 (0.118 in. (3.0 mm)) starting point shims for future reference. Insert Dummy Shims 8107 starting point shims between the dummy bearing and the axle housing (Fig. 81).

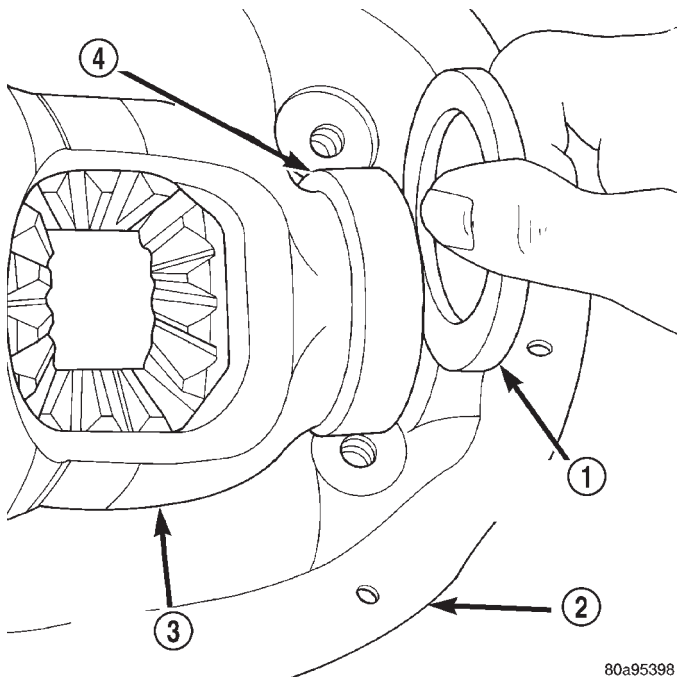

80a95398

Fig. 81 Insert Starting Point Shims

- 1 - SPECIAL TOOL 8107
- 2 - AXLE HOUSING
- 3 - DIFFERENTIAL CASE
- 4 - SPECIAL TOOL D-348

(6) Install the marked bearing caps in their correct positions. Install and snug the bolts.

(7) Using a dead-blow type mallet, seat the differential dummy bearings to each side of the axle housing (Fig. 82) and (Fig. 83).

(8) Thread guide stud C-3288-B into rear cover bolt hole below ring gear (Fig. 84).

(9) Attach dial indicator C-3339 to guide stud. Position the dial indicator plunger on a flat surface on a ring gear bolt head (Fig. 84).

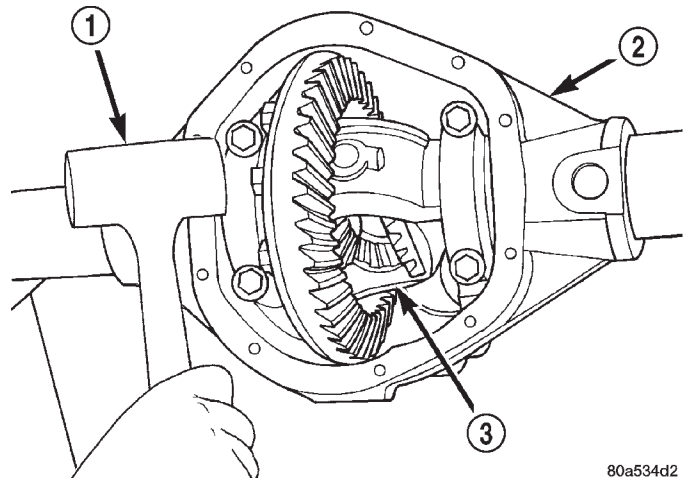

80a534d2

Fig. 82 Seat Pinion Gear Dummy Side Bearing

- 1 - MALLET
- 2 - AXLE HOUSING
- 3 - DIFFERENTIAL CASE

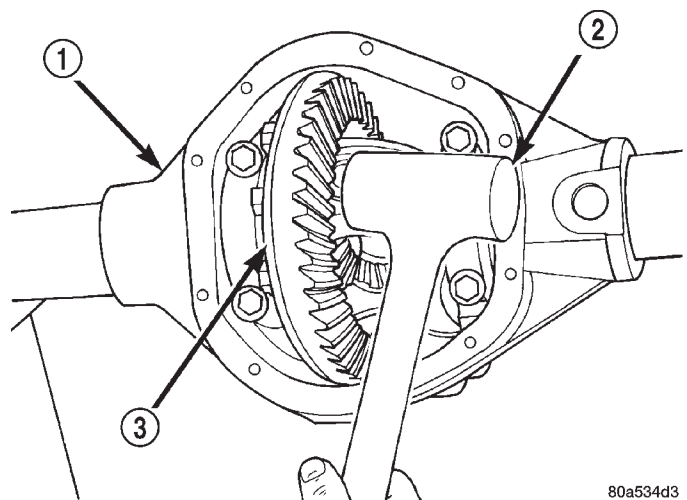

80a534d3

Fig. 83 Seat Ring Gear Side Dummy Bearing

- 1 - AXLE HOUSING
- 2 - MALLET
- 3 - DIFFERENTIAL CASE

(10) Push firmly and hold differential case to pinion gear side of axle housing (Fig. 85).

(11) Zero dial indicator face to pointer.

(12) Push firmly and hold differential case to ring gear side of the axle housing (Fig. 86).

(13) Record dial indicator reading.

(14) Add the dial indicator reading to the starting point shim thickness to determine total shim thickness to achieve zero differential end play.

(15) Add 0.006 in. (0.152 mm) to the zero end play total. This new total represents the thickness of shims to compress, or preload the new bearings when the differential is installed.

ADJUSTMENTS (Continued)

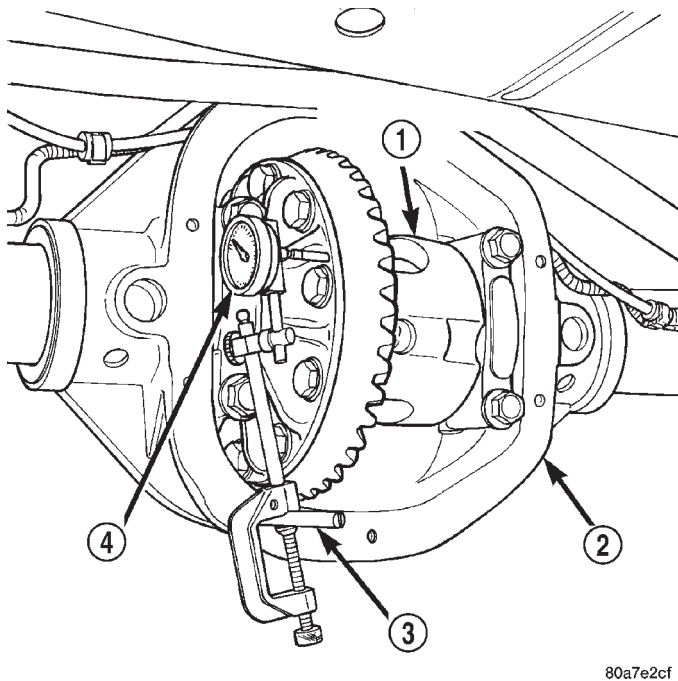

Fig. 84 Differential Side play Measurement

- 1 - DIFFERENTIAL CASE
- 2 - AXLE HOUSING
- 3 - SPECIAL TOOL C-3288-B
- 4 - SPECIAL TOOL C-3339

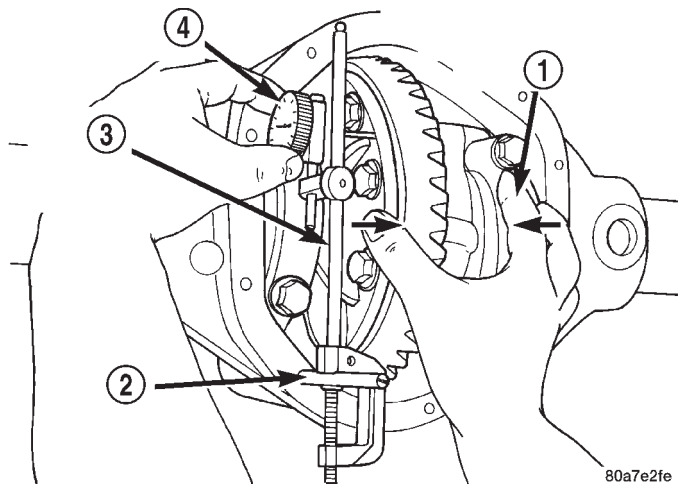

Fig. 85 Hold Differential Case and Zero Dial Indicator

- 1 - FORCE DIFFERENTIAL CASE TO PINION GEAR SIDE
- 2 - SPECIAL TOOL C-3288-B
- 3 - SPECIAL TOOL C-3339
- 4 - ZERO DIAL INDICATOR FACE

(16) Rotate dial indicator out of the way on guide stud.

(17) Remove differential case, dummy bearings, and starting point shims from axle housing.

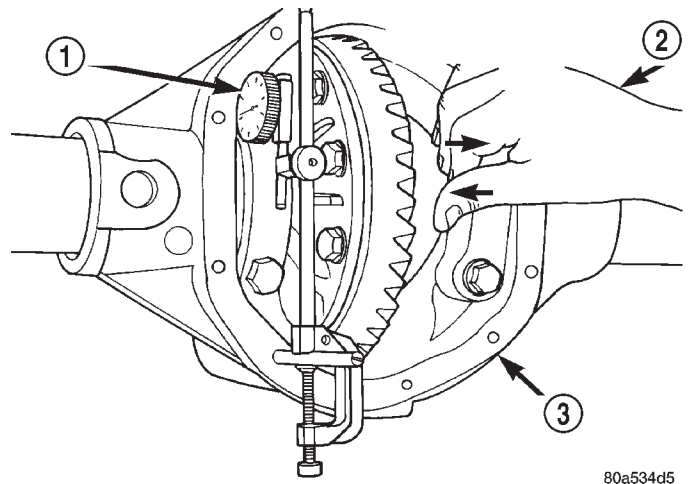

Fig. 86 Hold Differential Case and Read Dial Indicator

- 1 - READ DIAL INDICATOR
- 2 - FORCE DIFFERENTIAL CASE TO RING GEAR SIDE
- 3 - AXLE HOUSING

(18) Install pinion gear in axle housing. Install the yoke and establish the correct pinion rotating torque.

(19) Install differential case and dummy bearings in axle housing with a single Dummy Shim 8107 installed between the ring gear side dummy bearing and the axle housing. Install the bearing caps and tighten retaining cap bolts.

(20) Position the dial indicator plunger on a flat surface between the ring gear bolt heads (Fig. 84).

(21) Push and hold differential case toward pinion gear.

(22) Zero dial indicator face to pointer.

(23) Push and hold differential case to ring gear side of the axle housing.

(24) Record dial indicator reading. Add the starting point shim thickness to the dial indicator reading to obtain the total shim thickness necessary to achieve zero backlash.

(25) Subtract 0.003 in. (0.076 mm) from the dial indicator reading to compensate for backlash between ring and pinion gears. This total is the thickness of shim required to achieve proper backlash.

(26) Subtract the backlash shim thickness from the total preload shim thickness. The remainder is the shim thickness required on the pinion side of the axle housing.

(27) Rotate dial indicator out of the way on guide stud.

(28) Remove differential case, dummy shim, and dummy bearings from axle housing.

(29) Install new side bearing cones and cups on differential case.

(30) Install spreader W-129-B, utilizing some components of Adapter Set 6987, on axle housing and

ADJUSTMENTS (Continued)

spread axle opening enough to receive differential case.

(31) Place side bearing shims in axle housing against axle tubes.

(32) Install differential case in axle housing.

(33) Rotate the differential case several times to seat the side bearings.

(34) Position the indicator plunger against a ring gear tooth (Fig. 87).

(35) Push and hold ring gear upward while not allowing the pinion gear to rotate.

(36) Zero dial indicator face to pointer.

(37) Push and hold ring gear downward while not allowing the pinion gear to rotate. Dial indicator reading should be between 0.12 mm (0.005 in.) and 0.20 mm (0.008 in.). If backlash is not within specifications transfer the necessary amount of shim thickness from one side of the differential housing to the other (Fig. 88).

(38) Verify differential case and ring gear runout by measuring ring to pinion gear backlash at eight locations around the ring gear. Readings should not vary more than 0.05 mm (0.002 in.). If readings vary more than specified, the ring gear or the differential case is defective.

After the proper backlash is achieved, perform the Gear Contact Pattern Analysis procedure.

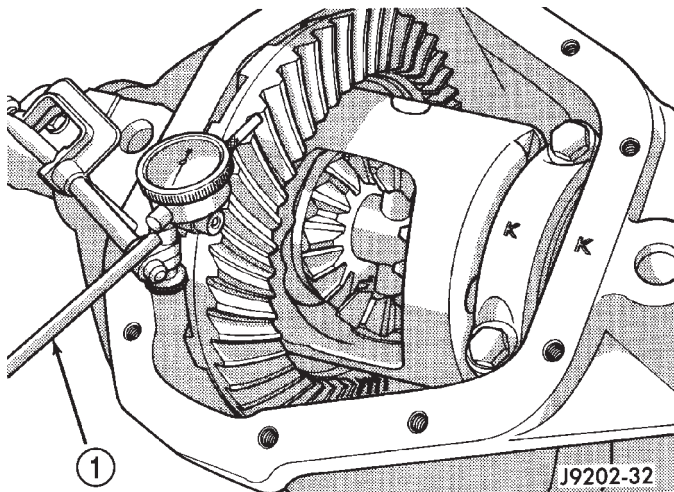

Fig. 87 Ring Gear Backlash Measurement

1 - DIAL INDICATOR

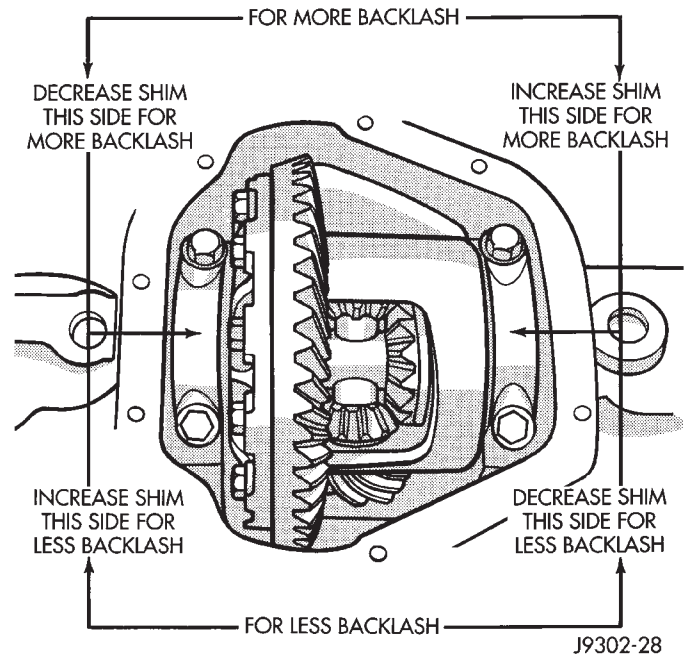

Fig. 88 Backlash Shim Adjustment

DIFFERENTIAL TOTAL TORQUE TO ROTATE

(1) Rotate the pinion a minimum of ten times to seat the differential bearings. Verify that the rotation is smooth and repeatable.

(2) While rotating the pinion at a slow steady rate, measure the differential total torque to rotate. Record the value.

(3) The differential total torque to rotate must be greater than the pinion torque to rotate plus 3 in.lbs..

(4) The differential total torque to rotate must be less than the pinion torque to rotate plus 11 in.lbs..

(5) If the differential total torque to rotate is within these guidelines, assemble the remainder of the axle.

(6) If the differential total torque to rotate is less than the required value, increase the shim thickness on the ring and pinion gear sides of the differential equally.

(7) If the differential total torque to rotate is greater than the required value, decrease the shim thickness on the ring and pinion gear sides of the differential equally.

(8) Remeasure the differential total torque to rotate.

ADJUSTMENTS (Continued)

GEAR CONTACT PATTERN ANALYSIS

The ring gear and pinion teeth contact patterns will show if the pinion depth is correct in the axle housing. It will also show if the ring gear backlash has been adjusted correctly. The backlash can be adjusted within specifications to achieve desired tooth contact patterns.

(1) Apply a thin coat of hydrated ferric oxide, or equivalent, to the drive and coast side of the ring gear teeth.

(2) Wrap, twist, and hold a shop towel around the pinion yoke to increase the turning resistance of the pinion. This will provide a more distinct contact pattern.

(3) Using a boxed end wrench on a ring gear bolt, rotate the differential case one complete revolution in both directions while a load is being applied from shop towel.

The areas on the ring gear teeth with the greatest degree of contact against the pinion teeth will squeeze the compound to the areas with the least amount of contact. Note and compare patterns on the ring gear teeth to Gear Tooth Contact Patterns chart (Fig. 89) and adjust pinion depth and gear backlash as necessary.

ADJUSTMENTS (Continued)

<p>DRIVE SIDE OF RING GEAR TEETH</p> <p>HEEL TOE</p> 	<p>COAST SIDE OF RING GEAR TEETH</p> <p>TOE HEEL</p> 	<p>DESIRABLE CONTACT PATTERN. PATTERN SHOULD BE CENTERED ON THE DRIVE SIDE OF TOOTH. PATTERN SHOULD BE CENTERED ON THE COAST SIDE OF TOOTH, BUT MAY BE SLIGHTLY TOWARD THE TOE. THERE SHOULD ALWAYS BE SOME CLEARANCE BETWEEN CONTACT PATTERN AND TOP OF THE TOOTH.</p>
		<p>RING GEAR BACKLASH CORRECT. THINNER PINION GEAR DEPTH SHIM REQUIRED.</p>
		<p>RING GEAR BACKLASH CORRECT. THICKER PINION GEAR DEPTH SHIM REQUIRED.</p>
		<p>PINION GEAR DEPTH SHIM CORRECT. DECREASE RING GEAR BACKLASH.</p>
		<p>PINION GEAR DEPTH SHIM CORRECT. INCREASE RING GEAR BACKLASH.</p>

Fig. 89 Gear Tooth Contact Patterns

SPECIFICATIONS

198 RBI AXLE

DESCRIPTION	SPECIFICATION
Axle Type	Semi-Floating Hypoid
Lubricant	SAE Thermally Stable 80W-90
Lubricant Trailer Tow	Synthetic 75W-140
Lube Capacity	1.66 L (3.50 pts.) total
Friction Modifier-w/ Trac-lok™	0.11 L (0.25 pts.)
Axle Ratios	3.07, 3.55, 3.73, 4.10
Differential Bearing Preload	0.1 mm (0.004 in.)
Differential Side Gear Clearance	0-0.15 mm (0-0.006 in.)
Ring Gear Diameter	19.8 cm (7.795 in.)
Ring Gear Backlash	0-0.15 mm (0.005-0.008 in.)
Pinion Std. Depth	92.08 mm (3.625 in.)
Pinion Bearing Preload-Original Bearings	1-2 N·m (10-20 in. lbs.)
Pinion Bearing Preload-New Bearings	1.7-3.4 N·m (15-30 in. lbs.)
Maximum Carrier Spread	0.51 mm (0.020 in.)

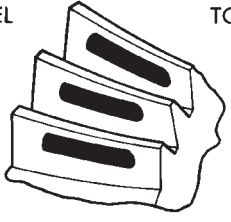
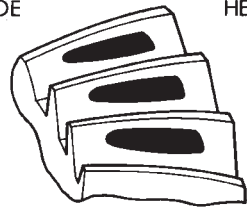
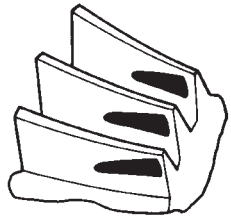
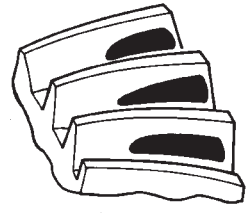
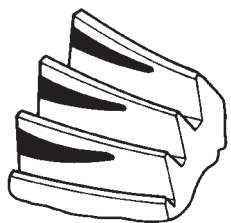
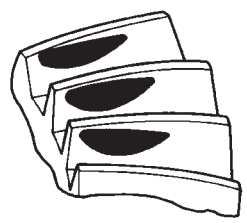
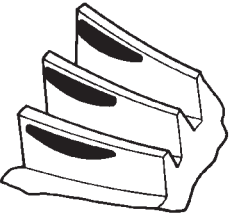
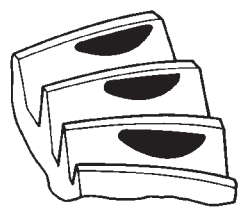
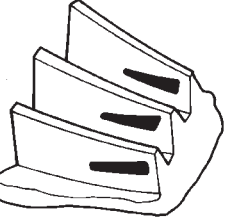
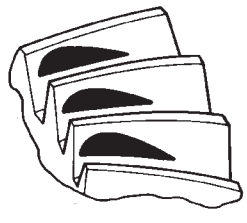
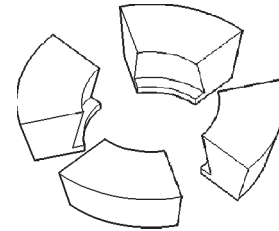

Adapter—8352

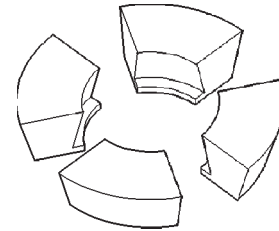

Adapter—C-293-40

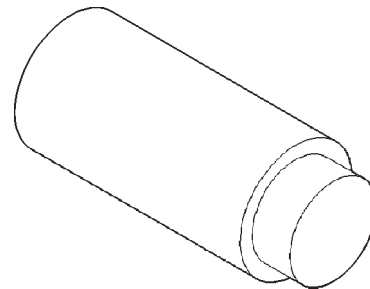

Plug—SP-3289

198 RBI AXLE

DESCRIPTION	TORQUE
Bolt, Diff. Cover	41 N·m (30 ft. lbs.)
Bolt, Bearing Cap	77 N·m (57 ft. lbs.)
Nut, Pinion	271-474 N·m (200-350 ft. lbs.)
Screw, Pinion Mate Shaft Lock	16.25 N·m (12 ft. lbs.)
Nuts, Axle Bearing Retainer Plate	61 N·m (45 ft. lbs.)
Bolt, Ring Gear	129-142 N·m (95-105 ft. lbs.)
Bolt, ABS Sensor	8 N·m (70 in. lbs.)

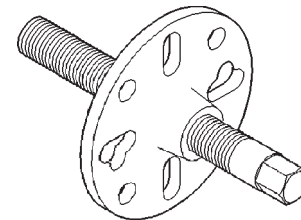

Puller—C-452

SPECIAL TOOLS

198 RBI AXLE

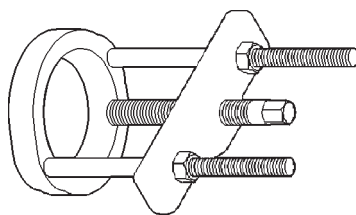

Puller—C-293-PA

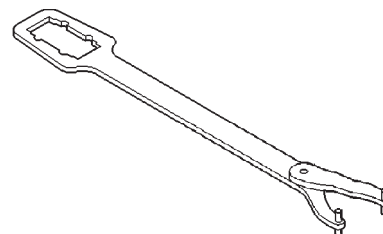

Wrench—C-3281

SPECIAL TOOLS (Continued)

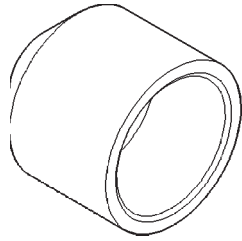

Installer—C-3972-A

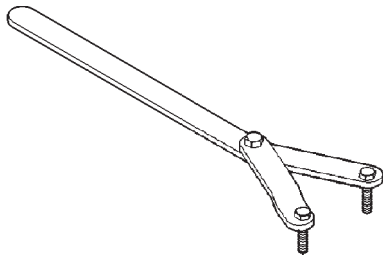

Spanner—6958

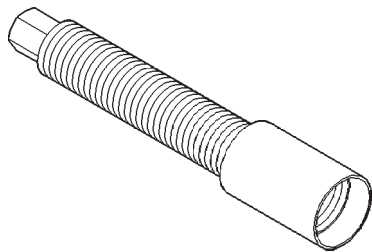

Installer Screw—8112

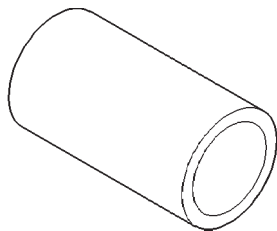

Cup—8109

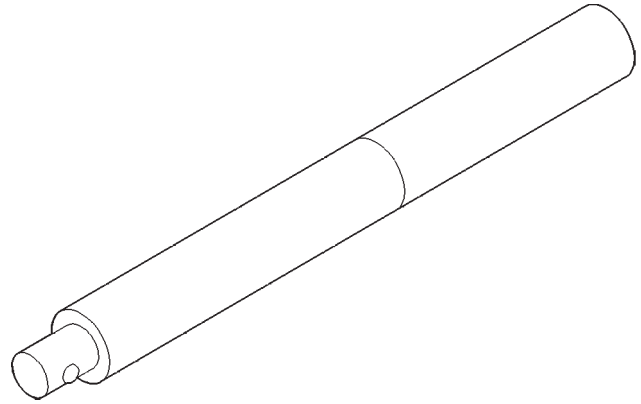

Handle—C-4171

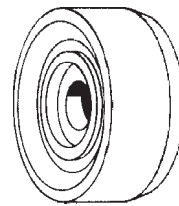

Driver—C-3716-A

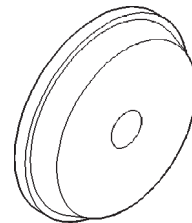

Installer—D-130



Installer—D-146

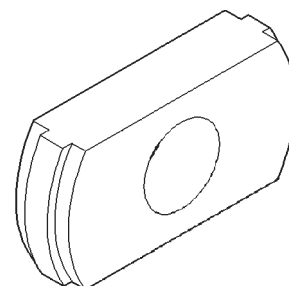

Remover—C-4345

SPECIAL TOOLS (Continued)

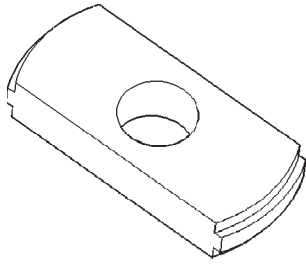

Remover—D-149

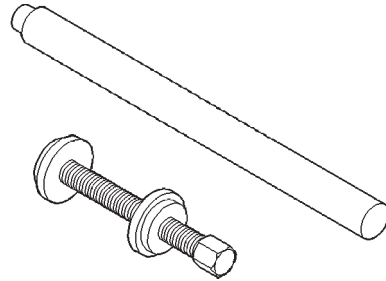

Trac-lok Tool Set—6960

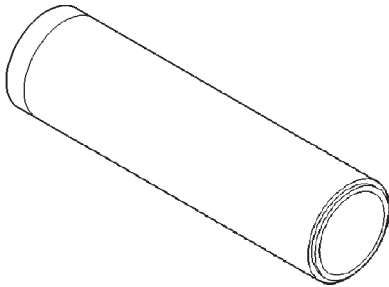

Installer—W-262

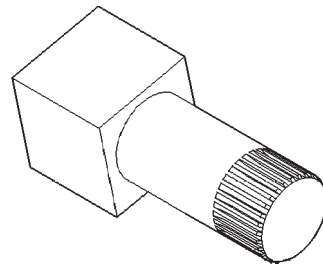

Holder—6965

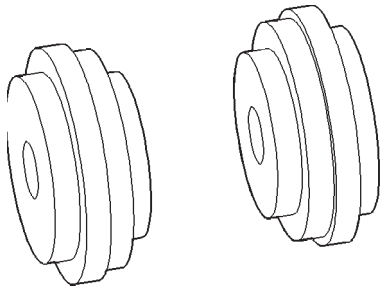

Disc, Axle Arbor—6732

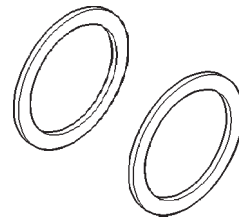

Starting Point Shim—8107

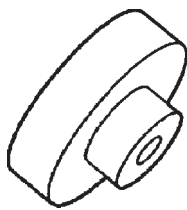

Gauge Block—6735

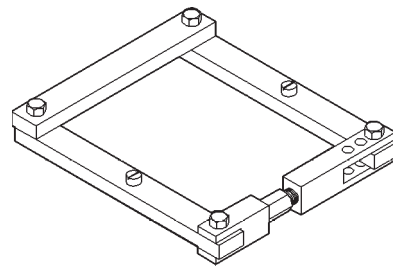

Spreader—W-129-B

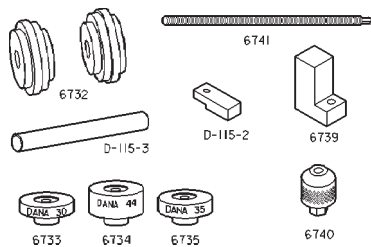

Tool Set, Pinion Depth—6774

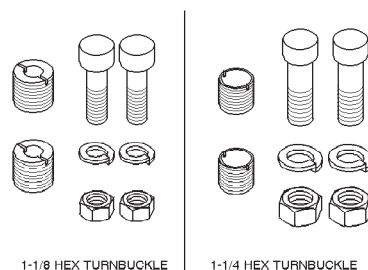

1-1/8 HEX TURNBUCKLE

1-1/4 HEX TURNBUCKLE

Adapter Kit—6987

SPECIAL TOOLS (Continued)

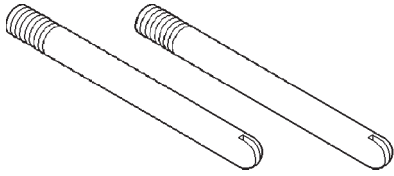

Guide Pin—C-3288-B

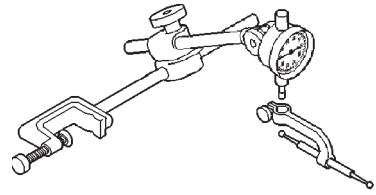

8011d42b

Dial Indicator—C-3339

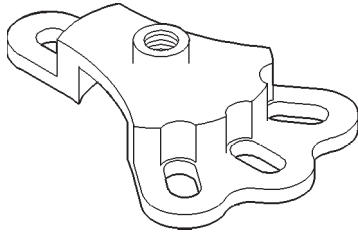

Hub Puller—6790

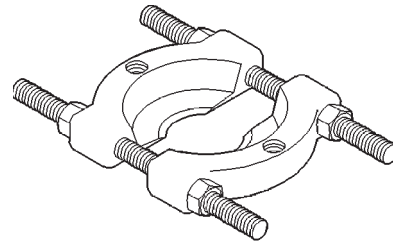

113C-80109ac3

Splitter, Bearing—1130

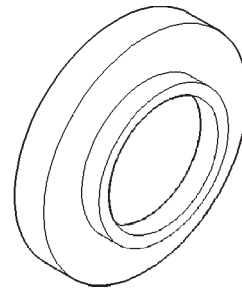

Installer, Gear/Bearing—7913-A

226 RBA AXLE

TABLE OF CONTENTS

	page		page
DESCRIPTION AND OPERATION			
226 RBA AXLE	95	AXLE SHAFT SEAL AND BEARING	110
LUBRICANT	96	DIFFERENTIAL	112
STANDARD DIFFERENTIAL	96	DIFFERENTIAL SIDE BEARINGS	114
VARI-LOK™ DIFFERENTIAL	97	VARI-LOK™ PLENUM	114
TRAC-LOK™ DIFFERENTIAL	98	RING GEAR	115
DIAGNOSIS AND TESTING			
GENERAL INFORMATION	98	PINION GEAR	115
GEAR NOISE	101	FINAL ASSEMBLY	120
BEARING NOISE	101	DISASSEMBLY AND ASSEMBLY	
LOW SPEED KNOCK	101	STANDARD DIFFERENTIAL	121
VIBRATION	101	TRAC-LOK™ DIFFERENTIAL	122
DRIVELINE SNAP	102	CLEANING AND INSPECTION	
TRAC-LOK™ DIFFERENTIAL NOISE	102	AXLE COMPONENTS	126
TRAC-LOK™ TEST	102	TRAC-LOK™	126
VARI-LOK™ TEST	102	ADJUSTMENTS	
SERVICE PROCEDURES			
LUBRICANT CHANGE	103	PINION GEAR DEPTH	127
REMOVAL AND INSTALLATION			
REAR AXLE	103	DIFFERENTIAL BEARING PRELOAD AND GEAR BACKLASH	129
PINION SHAFT SEAL	104	GEAR CONTACT PATTERN ANALYSIS	133
COLLAPSIBLE SPACER	106	SPECIFICATIONS	
AXLE SHAFT	109	226 RBA AXLE	135
		226 RBA AXLE	135
		SPECIAL TOOLS	
		226 RBA AXLE	135

DESCRIPTION AND OPERATION

226 RBA AXLE

DESCRIPTION

The 226 Rear Beam-design Aluminum (RBA) axle housing has an aluminum center casting (differential housing) with axle shaft tubes extending from either side. The tubes are pressed into the differential housing to form a one-piece axle housing.

The integral type housing, hypoid gear design has the center-line of the pinion set below the center-line of the ring gear.

The axle has a vent hose to relieve internal pressure caused by lubricant vaporization and internal expansion.

The axles are equipped with semi-floating axle shafts, meaning that vehicle load is supported by the axle shaft and bearings. The axle shafts are retained by bearing retainer plates on the axles which are bolted to flanges at the outboard end of the axle tubes.

The cover provides a means for servicing the differential without removing the axle.

For vehicles equipped with ABS brakes, the axles have a tone ring pressed onto the axle shaft. Use care when removing axle shafts to ensure that the tone wheel or the wheel speed sensor are not damaged.

The 226 RBA axle has the assembly part number and gear ratio listed on a tag. The tag is attached to the differential housing by a cover bolt. Build date identification codes are stamped on the cover side of an axle shaft tube.

The differential case is a one-piece design. The differential pinion mate shaft is retained with a threaded pin. Differential bearing preload and ring gear backlash is adjusted by the use of selective spacer shims. Pinion bearing preload is set and maintained by the use of a collapsible spacer (Fig. 1).

Axles equipped with a Trac-Lok™ differential are optional. A Trac-Lok differential has a one-piece differential case, and the same internal components as a standard differential, plus two clutch disc packs.

Axles equipped with a Vari-Lok™ differential are optional. A Vari-Lok™ differential has a one-piece differential case which contains the gerotor pump assembly and the clutch mechanism. The Vari-Lok™ unit is serviced only as an assembly.

DESCRIPTION AND OPERATION (Continued)

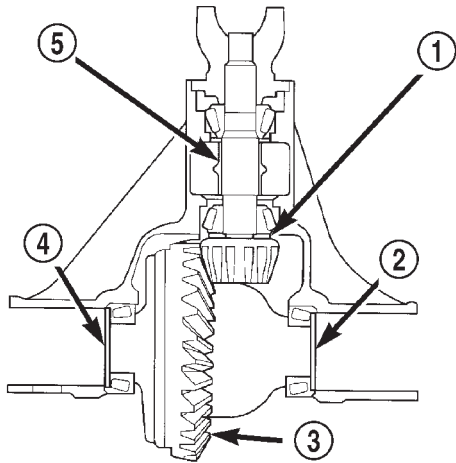

80a5037a

Fig. 1 Shim Locations

- 1 - PINION GEAR DEPTH SHIM
- 2 - DIFFERENTIAL BEARING SHIM-PINION GEAR SIDE
- 3 - RING GEAR
- 4 - DIFFERENTIAL BEARING SHIM-RING GEAR SIDE
- 5 - COLLAPSIBLE SPACER

OPERATION

The axle receives power from the transmission/transfer case through the rear propeller shaft. The rear propeller shaft is connected to the pinion gear which rotates the differential through the gear mesh with the ring gear bolted to the differential case. The engine power is transmitted to the axle shafts through the pinion mate and side gears. The side gears are splined to the axle shafts.

LUBRICANT**DESCRIPTION**

A multi-purpose, hypoid gear lubricant which conforms to the following specifications should be used. Mopar® Hypoid Gear Lubricant conforms to all of these specifications.

- The lubricant should have MIL-L-2105C and API GL 5 quality specifications.
- Lubricant is a thermally stable SAE 80W-90 gear lubricant.
- Lubricant for axles intended for heavy-duty or trailer tow use is SAE 75W-140 SYNTHETIC gear lubricant.

Trac-lok™ differentials require the addition of 0.11L (0.25 pts.) of friction modifier to the axle lubricant. The 226 RBA axle lubricant capacity is 2.24 L (4.75 pts.) total, including the friction modifier if necessary.

Vari-lok™ equipped axles require the addition of 0.12L (0.25 pts.) of friction modifier to the axle lubricant. The 226 RBA axle lubricant capacity for axles equipped with a Vari-lok™ differential is 2.25 L (4.75 pts.) total, including the friction modifier.

CAUTION: If axle is submerged in water, lubricant must be replaced immediately to avoid possible premature axle failure.

STANDARD DIFFERENTIAL**DESCRIPTION**

The differential gear system divides the torque between the axle shafts. It allows the axle shafts to rotate at different speeds when turning corners.

Each differential side gear is splined to an axle shaft. The pinion gears are mounted on a pinion mate shaft and are free to rotate on the shaft. The pinion gear is fitted in a bore in the differential case and is positioned at a right angle to the axle shafts.

OPERATION

In operation, power flow occurs as follows:

- The pinion gear rotates the ring gear
- The ring gear (bolted to the differential case) rotates the case
- The differential pinion gears (mounted on the pinion mate shaft in the case) rotate the side gears
- The side gears (splined to the axle shafts) rotate the shafts

During straight-ahead driving, the differential pinion gears do not rotate on the pinion mate shaft. This occurs because input torque applied to the gears is divided and distributed equally between the two side gears. As a result, the pinion gears revolve with the pinion mate shaft but do not rotate around it (Fig. 2).

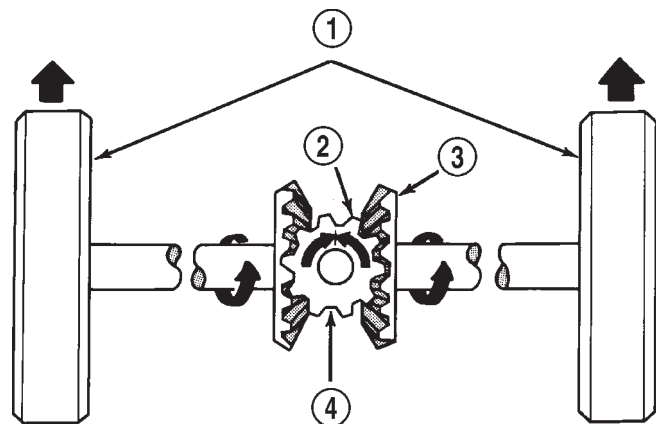

J9303-13

Fig. 2 Differential Operation—Straight Ahead Driving

- 1 - IN STRAIGHT AHEAD DRIVING EACH WHEEL ROTATES AT 100% OF CASE SPEED
- 2 - PINION GEAR
- 3 - SIDE GEAR
- 4 - PINION GEARS ROTATE WITH CASE

DESCRIPTION AND OPERATION (Continued)

When turning corners, the outside wheel must travel a greater distance than the inside wheel to complete a turn. The difference must be compensated for to prevent the tires from scuffing and skidding through turns. To accomplish this, the differential allows the axle shafts to turn at unequal speeds (Fig. 3). In this instance, the input torque applied to the pinion gears is not divided equally. The pinion gears now rotate around the pinion mate shaft in opposite directions. This allows the side gear and axle shaft attached to the outside wheel to rotate at a faster speed.

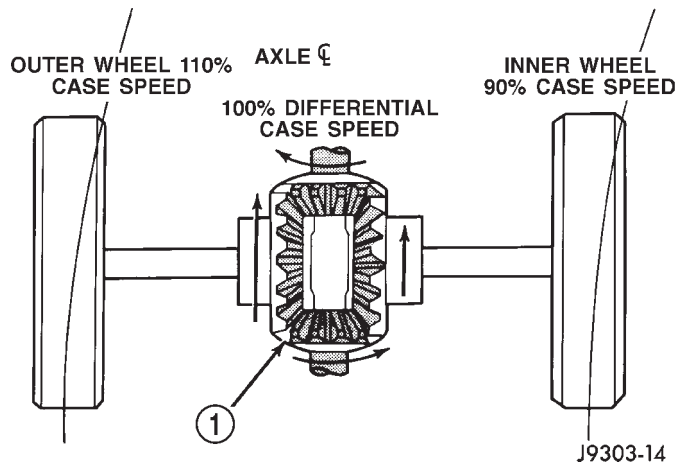

Fig. 3 Differential Operation—On Turns

1 - PINION GEARS ROTATE ON PINION SHAFT

OPERATION

In a standard differential, if one wheel spins, the opposite wheel will generate only as much torque as the spinning wheel.

A gerotor pump and clutch pack are used to provide the torque transfer capability. One axle shaft is splined to the gerotor pump and one of the differential side gears, which provides the input to the pump. As a wheel begins to lose traction, the speed differential is transmitted from one side of the differential to the other through the side gears. The motion of one side gear relative to the other turns the inner rotor of the pump. Since the outer rotor of the pump is grounded to the differential case, the inner and outer rotors are now moving relative to each other and therefore creates pressure in the pump. The tuning of the front and rear axle orifices and valves inside the gerotor pump is unique and each system includes a torque-limiting pressure relief valve to protect the clutch pack, which also facilitates vehicle control under extreme side-to-side traction variations. The resulting pressure is applied to the clutch pack and the transfer of torque is completed.

Under conditions in which opposite wheels are on surfaces with widely different friction characteristics, Vari-lok™ delivers far more torque to the wheel on the higher traction surface than do conventional Trac-lok™ systems. Because conventional Trac-lok™ differentials are initially pre-loaded to assure torque transfer, normal driving (where inner and outer wheel speeds differ during cornering, etc.) produces torque transfer during even slight side-to-side speed variations. Since these devices rely on friction from this preload to transfer torque, normal use tends to cause wear that reduces the ability of the differential to transfer torque over time. By design, the Vari-lok™ system is less subject to wear, remaining more consistent over time in its ability to transfer torque. The coupling assembly is serviced as a unit. From a service standpoint the coupling also benefits from using the same lubricant supply as the ring and pinion gears.

VARI-LOK™ DIFFERENTIAL

DESCRIPTION

Vari-lok™ differentials are a speed-sensing torque transfer differential. Similiar to Trac-lok™ differentials, these differentials transfer torque to the wheel with the greater traction. Unlike typical differential systems, torque transfer is proportional to wheel speed difference rather than torque difference. Response can be tuned to driving conditions, enabling use of this system in the front axle. Both front and rear Vari-lok™ axle torque transfer characteristics are tuned to provide smooth operation. Except for the ability to maintain headway under low-traction conditions, operation is barely noticeable to the driver.

DESCRIPTION AND OPERATION (Continued)

TRAC-LOK™ DIFFERENTIAL**DESCRIPTION**

In a standard differential, if one wheel spins, the opposite wheel will generate only as much torque as the spinning wheel.

In the Trac-lok™ differential, part of the ring gear torque is transmitted through clutch packs which contain multiple discs. The clutches will have radial grooves on the plates, and concentric grooves on the discs or bonded fiber material that is smooth in appearance.

OPERATION

In operation, the Trac-lok™ clutches are engaged by two concurrent forces. The first being the preload force exerted through Belleville spring washers within the clutch packs. The second is the separating forces generated by the side gears as torque is applied through the ring gear (Fig. 4).

The Trac-lok™ design provides the differential action needed for turning corners and for driving straight ahead during periods of unequal traction. When one wheel loses traction, the clutch packs transfer additional torque to the wheel having the most traction. Trac-lok™ differentials resist wheel spin on bumpy roads and provide more pulling power when one wheel loses traction. Pulling power is provided continuously until both wheels lose traction. If both wheels slip due to unequal traction, Trac-lok™ operation is normal. In extreme cases of differences of traction, the wheel with the least traction may spin.

DIAGNOSIS AND TESTING**GENERAL INFORMATION**

Axle bearing problem conditions are usually caused by:

- Insufficient or incorrect lubricant.
- Foreign matter/water contamination.
- Incorrect bearing preload torque adjustment.
- Incorrect backlash.

Axle gear problem conditions are usually the result of:

- Insufficient lubrication.
- Incorrect or contaminated lubricant.
- Overloading (excessive engine torque) or exceeding vehicle weight capacity.

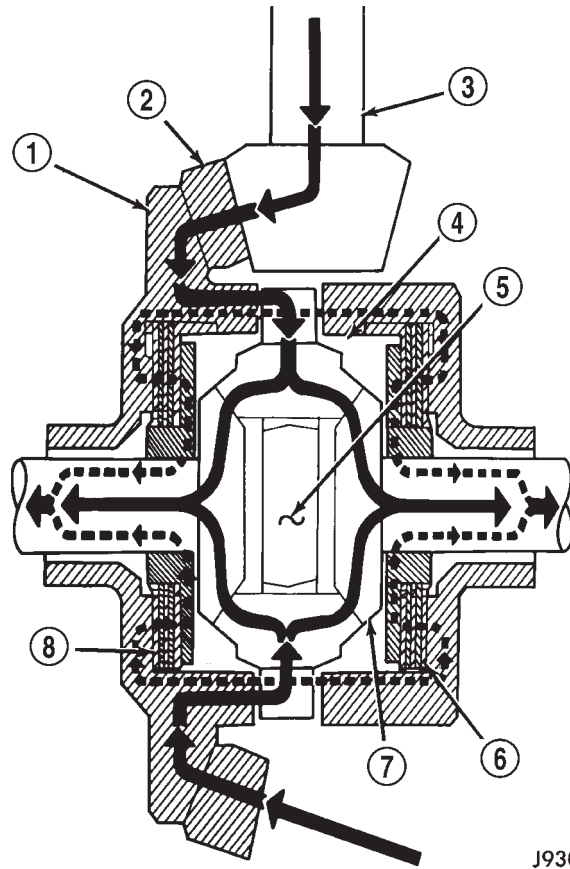

J9303-15

Fig. 4 Trac-lok™ Limited Slip Differential Operation

- 1 - CASE
- 2 - RING GEAR
- 3 - DRIVE PINION
- 4 - PINION GEAR
- 5 - MATE SHAFT
- 6 - CLUTCH PACK
- 7 - SIDE GEAR
- 8 - CLUTCH PACK

- Incorrect clearance or backlash adjustment.
- Axle component breakage is most often the result of:
- Severe overloading.
 - Insufficient lubricant.
 - Incorrect lubricant.
 - Improperly tightened components.
 - Differential housing bores not square to each other.

DIAGNOSIS AND TESTING (Continued)

DIAGNOSTIC CHART

Condition	Possible Causes	Correction
Wheel Noise	<ol style="list-style-type: none"> 1. Wheel loose. 2. Faulty, brinelled wheel bearing. 	<ol style="list-style-type: none"> 1. Tighten loose nuts. 2. Replace bearing.
Axle Shaft Noise	<ol style="list-style-type: none"> 1. Misaligned axle tube. 2. Bent or sprung axle shaft. 3. End-play in pinion bearings. 4. Excessive gear backlash between the ring gear and pinion. 5. Improper adjustment of pinion gear bearings. 6. Loose pinion yoke nut. 7. Scuffed gear tooth contact surfaces. 	<ol style="list-style-type: none"> 1. Inspect axle tube alignment. Correct as necessary. 2. Inspect and correct as necessary. 3. Refer to pinion pre-load information and correct as necessary. 4. Check adjustment of the ring gear and pinion backlash. Correct as necessary. 5. Adjust the pinion bearings pre-load. 6. Tighten the pinion yoke nut. 7. Inspect and replace as necessary.
Axle Shaft Broke	<ol style="list-style-type: none"> 1. Misaligned axle tube. 2. Vehicle overloaded. 3. Erratic clutch operation. 4. Grabbing clutch. 	<ol style="list-style-type: none"> 1. Replace the broken shaft after correcting tube mis-alignment. 2. Replace broken shaft and avoid excessive weight on vehicle. 3. Replace broken shaft and avoid or correct erratic clutch operation. 4. Replace broken shaft and inspect and repair clutch as necessary.
Differential Cracked	<ol style="list-style-type: none"> 1. Improper adjustment of the differential bearings. 2. Excessive ring gear backlash. 3. Vehicle overloaded. 4. Erratic clutch operation. 	<ol style="list-style-type: none"> 1. Replace case and inspect gears and bearings for further damage. Set differential bearing pre-load properly. 2. Replace case and inspect gears and bearings for further damage. Set ring gear backlash properly. 3. Replace case and inspect gears and bearings for further damage. Avoid excessive vehicle weight. 4. Replace case and inspect gears and bearings for further damage. Avoid erratic use of clutch.

DIAGNOSIS AND TESTING (Continued)

Condition	Possible Causes	Correction
Differential Gears Scored	<ol style="list-style-type: none"> 1. Insufficient lubrication. 2. Improper grade of lubricant. 3. Excessive spinning of one wheel/tire. 	<ol style="list-style-type: none"> 1. Replace scored gears. Fill differential with the correct fluid type and quantity. 2. Replace scored gears. Fill differential with the correct fluid type and quantity. 3. Replace scored gears. Inspect all gears, pinion bores, and shaft for damage. Service as necessary.
Loss Of Lubricant	<ol style="list-style-type: none"> 1. Lubricant level too high. 2. Worn axle shaft seals. 3. Cracked differential housing. 4. Worn pinion seal. 5. Worn/scored yoke. 6. Axle cover not properly sealed. 	<ol style="list-style-type: none"> 1. Drain lubricant to the correct level. 2. Replace seals. 3. Repair as necessary. 4. Replace seal. 5. Replace yoke and seal. 6. Remove, clean, and re-seal cover.
Axle Overheating	<ol style="list-style-type: none"> 1. Lubricant level low. 2. Improper grade of lubricant. 3. Bearing pre-loads too high. 4. Insufficient ring gear backlash. 	<ol style="list-style-type: none"> 1. Fill differential to correct level. 2. Fill differential with the correct fluid type and quantity. 3. Re-adjust bearing pre-loads. 4. Re-adjust ring gear backlash.
Gear Teeth Broke	<ol style="list-style-type: none"> 1. Overloading. 2. Erratic clutch operation. 3. Ice-spotted pavement. 4. Improper adjustments. 	<ol style="list-style-type: none"> 1. Replace gears. Examine other gears and bearings for possible damage. 2. Replace gears and examine the remaining parts for damage. Avoid erratic clutch operation. 3. Replace gears and examine remaining parts for damage. 4. Replace gears and examine remaining parts for damage. Ensure ring gear backlash is correct.

DIAGNOSIS AND TESTING (Continued)

Condition	Possible Causes	Correction
Axle Noise	<ol style="list-style-type: none"> 1. Insufficient lubricant. 2. Improper ring gear and pinion adjustment. 3. Unmatched ring gear and pinion. 4. Worn teeth on ring gear and/or pinion. 5. Loose pinion bearings. 6. Loose differential bearings. 7. Mis-aligned or sprung ring gear. 8. Loose differential bearing cap bolts. 9. Housing not machined properly. 	<ol style="list-style-type: none"> 1. Fill differential with the correct fluid type and quantity. 2. Check ring gear and pinion contact pattern. 3. Replace gears with a matched ring gear and pinion. 4. Replace ring gear and pinion. 5. Adjust pinion bearing pre-load. 6. Adjust differential bearing pre-load. 7. Measure ring gear run-out. Replace components as necessary. 8. Inspect differential components and replace as necessary. Ensure that the bearing caps are torqued to the proper specification. 9. Replace housing.

GEAR NOISE

Axle gear noise can be caused by insufficient lubricant, incorrect backlash, tooth contact, worn/damaged gears, or the carrier housing not having the proper offset and squareness.

Gear noise usually happens at a specific speed range. The noise can also occur during a specific type of driving condition. These conditions are acceleration, deceleration, coast, or constant load.

When road testing, first warm-up the axle fluid by driving the vehicle at least 5 miles and then accelerate the vehicle to the speed range where the noise is the greatest. Shift out-of-gear and coast through the peak-noise range. If the noise stops or changes greatly:

- Check for insufficient lubricant.
- Incorrect ring gear backlash.
- Gear damage.

Differential side gears and pinions can be checked by turning the vehicle. They usually do not cause noise during straight-ahead driving when the gears are unloaded. The side gears are loaded during vehicle turns. A worn pinion mate shaft can also cause a snapping or a knocking noise.

BEARING NOISE

The axle shaft, differential and pinion bearings can all produce noise when worn or damaged. Bearing noise can be either a whining, or a growling sound.

Pinion bearings have a constant-pitch noise. This noise changes only with vehicle speed. Pinion bearing noise will be higher pitched because it rotates at a

faster rate. Drive the vehicle and load the differential. If bearing noise occurs, the rear pinion bearing is the source of the noise. If the bearing noise is heard during a coast, the front pinion bearing is the source.

Worn or damaged differential bearings usually produce a low pitch noise. Differential bearing noise is similar to pinion bearing noise. The pitch of differential bearing noise is also constant and varies only with vehicle speed.

Axle shaft bearings produce noise and vibration when worn or damaged. The noise generally changes when the bearings are loaded. Road test the vehicle. Turn the vehicle sharply to the left and to the right. This will load the bearings and change the noise level. Where axle bearing damage is slight, the noise is usually not noticeable at speeds above 30 mph.

LOW SPEED KNOCK

Low speed knock is generally caused by a worn U-joint or by worn side-gear thrust washers. A worn pinion shaft bore will also cause low speed knock.

VIBRATION

Vibration at the rear of the vehicle is usually caused by a:

- Damaged drive shaft.
- Missing drive shaft balance weight(s).
- Worn or out-of-balance wheels.
- Loose wheel lug nuts.
- Worn U-joint(s).
- Loose/broken springs.

DIAGNOSIS AND TESTING (Continued)

- Damaged axle shaft bearing(s).
- Loose pinion gear nut.
- Excessive pinion yoke run out.
- Bent axle shaft(s).

Check for loose or damaged front-end components or engine/transmission mounts. These components can contribute to what appears to be a rear-end vibration. Do not overlook engine accessories, brackets and drive belts.

All driveline components should be examined before starting any repair.

Refer to Group 22, Wheels and Tires, for additional vibration information.

DRIVELINE SNAP

A snap or clunk noise when the vehicle is shifted into gear (or the clutch engaged), can be caused by:

- High engine idle speed.
- Transmission shift operation.
- Loose engine/transmission/transfer case mounts.
- Worn U-joints.
- Loose spring mounts.
- Loose pinion gear nut and yoke.
- Excessive ring gear backlash.
- Excessive side gear to case clearance.

The source of a snap or a clunk noise can be determined with the assistance of a helper. Raise the vehicle on a hoist with the wheels free to rotate. Instruct the helper to shift the transmission into gear. Listen for the noise, a mechanics stethoscope is helpful in isolating the source of a noise.

TRAC-LOK™ DIFFERENTIAL NOISE

The most common problem is a chatter noise when turning corners. Before removing a Trac-lok™ unit for repair, drain, flush and refill the axle with the specified lubricant. Refer to Lubricant change in this Group.

A container of Mopar® Trac-lok™ Lubricant (friction modifier) should be added after repair service or during a lubricant change.

After changing the lubricant, drive the vehicle and make 10 to 12 slow, figure-eight turns. This maneuver will pump lubricant through the clutches. This will correct the condition in most instances. If the chatter persists, clutch damage could have occurred.

TRAC-LOK™ TEST

WARNING: WHEN SERVICING VEHICLES WITH A TRAC-LOK™ DIFFERENTIAL DO NOT USE THE ENGINE TO TURN THE AXLE AND WHEELS. BOTH REAR WHEELS MUST BE RAISED AND THE VEHICLE SUPPORTED. A TRAC-LOK™ AXLE CAN EXERT ENOUGH FORCE IF ONE WHEEL IS IN CON-

TACT WITH A SURFACE TO CAUSE THE VEHICLE TO MOVE.

The differential can be tested without removing the differential case by measuring rotating torque. Make sure brakes are not dragging during this measurement.

(1) Place blocks in front and rear of both front wheels.

(2) Raise one rear wheel until it is completely off the ground.

(3) Engine off, transmission in neutral, and parking brake off.

(4) Remove wheel and bolt Special Tool 6790 to studs.

(5) Use torque wrench on special tool to rotate wheel and read rotating torque (Fig. 5).

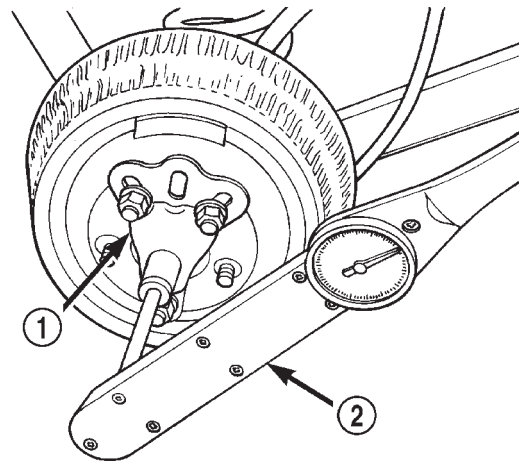

80a4d327

Fig. 5 Trac-lok™ Test —Typical

- 1 - SPECIAL TOOL 6790 WITH BOLT IN CENTER HOLE
2 - TORQUE WRENCH

(6) If rotating torque is less than 22 N-m (30 ft. lbs.) or more than 271 N-m (200 ft. lbs.) on either wheel the unit should be serviced.

VARI-LOK™ TEST**PRIMING**

(1) Park the vehicle on a level surface or raise vehicle on hoist so that the vehicle is level.

(2) Remove the axle fill plug.

(3) Verify that the axle fluid level is correct. The fluid level is correct if the fluid is level with the bottom of the fill hole.

(4) Shift the transfer case into the 4WD full-time position.

(5) Drive the vehicle in a tight circle for 2 minutes at 5mph to fully prime the pump.

DIAGNOSIS AND TESTING (Continued)

TEST PROCEDURE

- (1) Block the tires opposite the axle to be tested to prevent the vehicle from moving.
- (2) Shift the transfer case into the 4WD Low position and the transmission into the Park position.
- (3) Raise both the wheels of the axle to be tested off of the ground.
- (4) Rotate the left wheel by hand at a minimum of one revolution per second while an assistant rotates the right wheel in the opposite direction.
- (5) The left wheel should spin freely at first and then increase in resistance within 5 revolutions until the wheels cannot be continuously rotated in opposite directions.
- (6) The Vari-lok™ differential has engaged properly if the wheels cannot be rotated in opposite directions for a moment. After the wheels stop rotating for a moment, the fluid pressure will drop in the differential and the wheels begin to rotate once again.
- (7) If the system does not operate properly, replace the Vari-lok™ differential.

SERVICE PROCEDURES

LUBRICANT CHANGE

- (1) Raise and support the vehicle.
 - (2) Remove the lubricant fill hole plug from the differential housing cover.
 - (3) Remove the differential housing cover and drain the lubricant from the housing.
 - (4) Clean the housing cavity with a flushing oil, light engine oil, or lint free cloth. **Do not use water, steam, kerosene, or gasoline for cleaning.**
 - (5) Remove the original sealant from the housing and cover surfaces.
 - (6) Apply a bead of Mopar® Silicone Rubber Sealant, or equivalent, to the housing cover (Fig. 6).
- Install the housing cover within 5 minutes after applying the sealant.**
- (7) Install the cover and any identification tag. Tighten the cover bolts to 41 N·m (30 ft. lbs.) torque.
 - (8) For Trac-lok™ and Vari-lok™ differentials, a quantity of Mopar® Trac-lok™ lubricant (friction modifier), or equivalent, must be added after repair service or a lubricant change. Refer to the Lubricant Specifications section of this group for the quantity necessary.

- (9) Fill differential with correct lubricant to bottom of the fill plug hole. Refer to the Lubricant Specifications section of this group for the quantity necessary.

CAUTION: Overfilling the differential can result in lubricant foaming and overheating.

- (10) Install the fill hole plug and lower the vehicle.

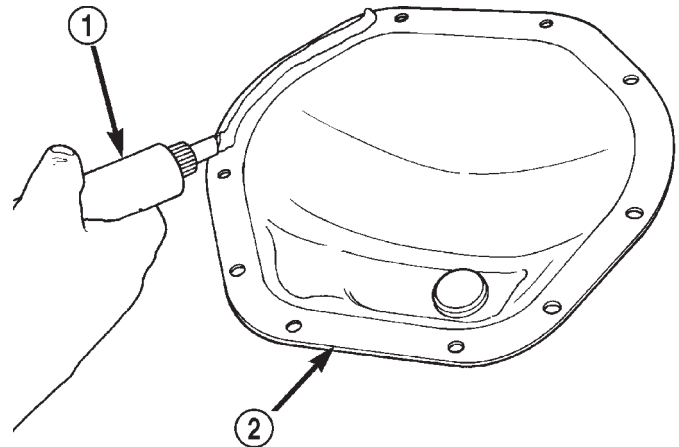

80a534a8

Fig. 6 Apply Sealant

- 1 - SEALANT
2 - AXLE HOUSING COVER

- (11) Trac-lok™ and Vari-lok™ differential equipped vehicles should be road tested by making 10 to 12 slow figure-eight turns. This maneuver will pump the lubricant through the clutch discs to eliminate a possible chatter noise complaint.

REMOVAL AND INSTALLATION

REAR AXLE

REMOVAL

- (1) Raise and support the vehicle.
- (2) Position a suitable lifting device under the axle.
- (3) Secure axle to device.
- (4) Remove the wheels and tires.
- (5) Remove the brake rotors and calipers from the axle. Refer to Group 5, Brakes, for proper procedures.
- (6) Disconnect parking brake cables from brackets and lever.
- (7) Remove wheel speed sensors, if necessary. Refer to Group 5, Brakes, for proper procedures.
- (8) Disconnect the brake hose at the axle junction block. Do not disconnect the brake hydraulic lines at the calipers. Refer to Group 5, Brakes, for proper procedures.
- (9) Disconnect the vent hose from the axle shaft tube.
- (10) Mark the propeller shaft and yokes for installation alignment reference.
- (11) Remove propeller shaft.
- (12) Disconnect stabilizer bar links.
- (13) Remove nut holding upper suspension arm to the rear axle ball joint.
- (14) Using Remover 8278, separate the rear axle ball joint from the upper suspension arm (Fig. 7).

REMOVAL AND INSTALLATION (Continued)

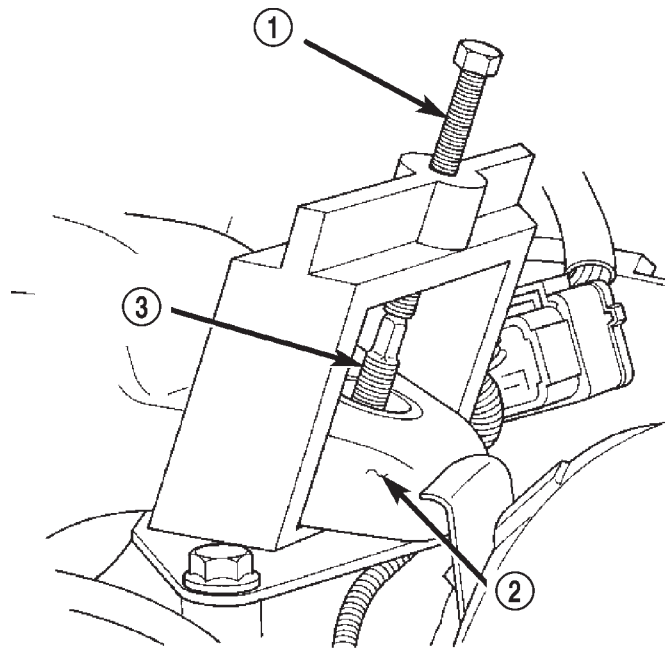
**Fig. 7 Separate Rear Axle Ball Joint**

- 1 - REMOVER
- 2 - UPPER SUSPENSION ARM
- 3 - BALL JOINT STUD

- (15) Disconnect shock absorbers from axle.
- (16) Disconnect track bar.
- (17) Disconnect lower suspension arms from the axle brackets.
- (18) Separate the axle from the vehicle.

INSTALLATION

NOTE: The weight of the vehicle must be supported by the springs before suspension arms and track bar fasteners can be tightened. If the springs are not at their normal ride position, vehicle ride height and handling could be affected.

- (1) Raise the axle with lifting device and align coil springs.
- (2) Position the lower suspension arms on the axle brackets. Install nuts and bolts, do not tighten bolts at this time.
- (3) Install the upper suspension arm to the rear axle ball joint.
- (4) Install nut to hold the upper suspension arm to the rear axle ball joint. Torque the nut to 122 N·m (90 ft.lbs.) (Fig. 8).
- (5) Install track bar and attachment bolts, do not tighten bolts at this time.
- (6) Install shock absorbers and tighten nuts to 60 N·m (44 ft. lbs.) torque.
- (7) Install stabilizer bar links and tighten nuts to 36 N·m (27 ft. lbs.) torque.

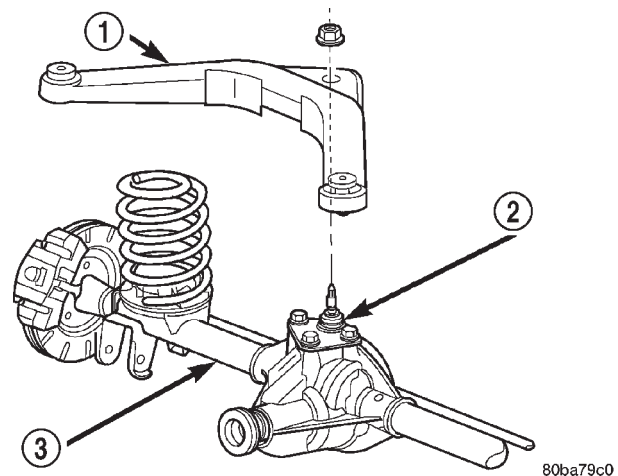
**Fig. 8 Install Rear Ball Joint Nut**

- 1 - UPPER SUSPENSION ARM
- 2 - REAR AXLE BALL JOINT
- 3 - REAR AXLE

- (8) Install the wheel speed sensors, if necessary. Refer to Group 5, Brakes, for proper procedures.
- (9) Connect parking brake cable to brackets and lever.
- (10) Install the brake rotors and calipers. Refer to Group 5, Brakes, for proper procedures.
- (11) Connect the brake hose to the axle junction block. Refer to Group 5, Brakes, for proper procedures.
- (12) Install axle vent hose.
- (13) Align propeller shaft and pinion yoke reference marks. Install U-joint straps and bolts. Tighten to 19 N·m (14 ft. lbs.) torque.
- (14) Install the wheels and tires.
- (15) Add gear lubricant, if necessary. Refer to Lubricant Specifications in this section for lubricant requirements.
- (16) Remove lifting device from axle and lower the vehicle.
- (17) Tighten lower suspension arm bolts to 177 N·m (130 ft. lbs.) torque.
- (18) Tighten track bar bolts to 100 N·m (74 ft. lbs.) torque.

PINION SHAFT SEAL**REMOVAL**

- (1) Raise and support the vehicle.
- (2) Remove wheel and tire assemblies.
- (3) Remove rear brake rotors and calipers. Refer to Group 5, Brakes, for proper procedures.
- (4) Mark the propeller shaft and pinion yoke for installation reference.
- (5) Remove the propeller shaft from the yoke.
- (6) Rotate the pinion gear three or four times.

REMOVAL AND INSTALLATION (Continued)

(7) Measure the amount of torque necessary to rotate the pinion gear with a (in. lbs.) dial-type torque wrench. Record the torque reading for installation reference.

(8) Using a short piece of pipe and Holder 6958 to hold the pinion yoke, remove the pinion nut and washer (Fig. 9).

(9) Use Remover C-452 and Wrench C-3281 to remove the pinion yoke (Fig. 10).

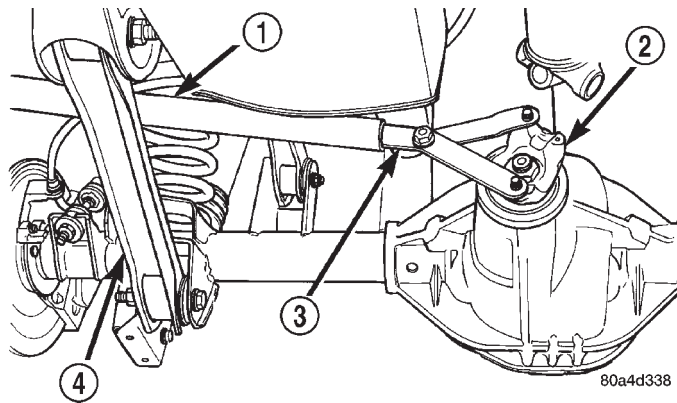

Fig. 9 Pinion Yoke Holder

- 1 - 1 in. PIPE
- 2 - PINION YOKE
- 3 - SPECIAL TOOL 6958
- 4 - LOWER CONTROL ARM

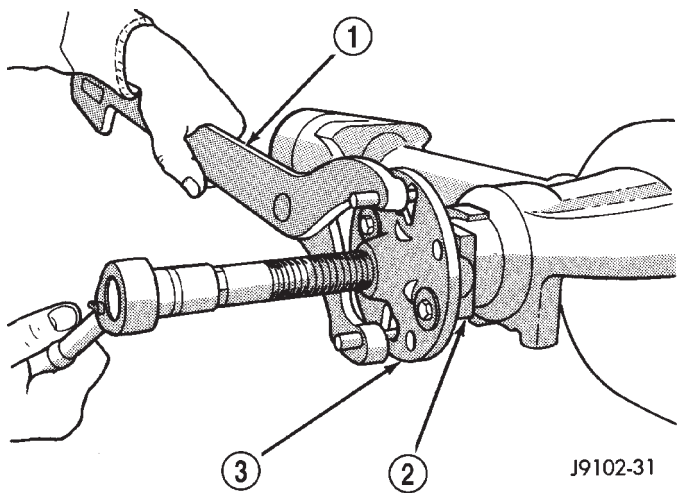
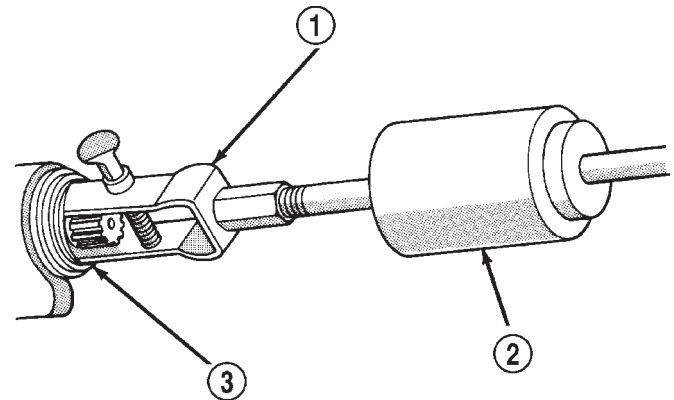

Fig. 10 Pinion Yoke Removal

- 1 - SPECIAL TOOL C-3281
- 2 - YOKE
- 3 - SPECIAL TOOL C-452

(10) Use Remover 7794-A and slide hammer to remove the pinion shaft seal (Fig. 11).



J9402-59X

Fig. 11 Seal Removal

- 1 - SPECIAL TOOL 7794A
- 2 - SLIDE HAMMER
- 3 - PINION SEAL

INSTALLATION

(1) Apply a light coating of gear lubricant on the lip of pinion seal. Install seal with Installer C-3972-A and Handle C-4171 (Fig. 12).

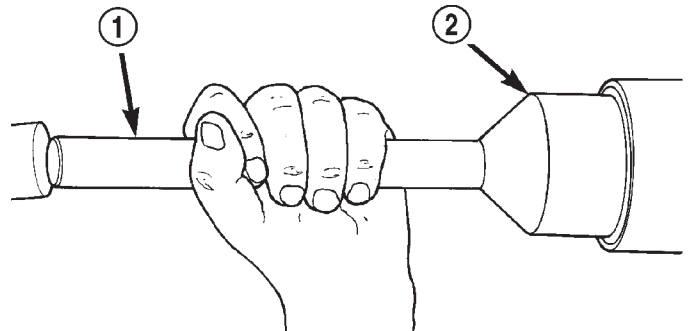

80a7e2be

Fig. 12 Pinion Seal Installation

- 1 - SPECIAL TOOL C-4171
- 2 - SPECIAL TOOL C-3972-A

REMOVAL AND INSTALLATION (Continued)

(2) Install yoke on the pinion gear with Installer C-3718 and Holder 6958 (Fig. 13).

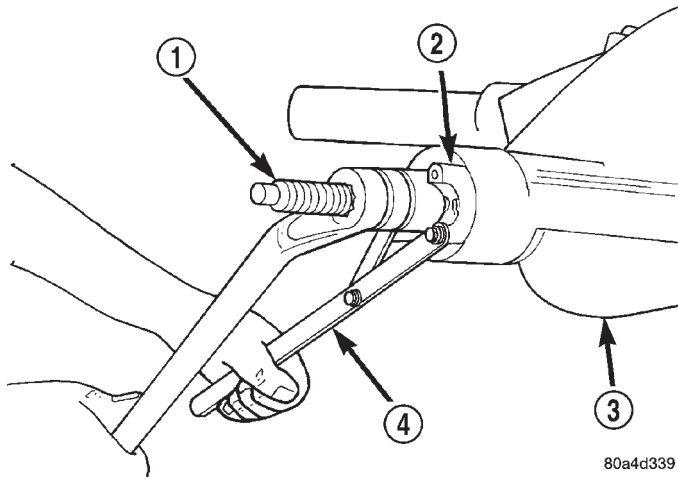

Fig. 13 Pinion Yoke Installation

- 1 - SPECIAL TOOL C-3718
- 2 - PINION YOKE
- 3 - AXLE HOUSING
- 4 - SPECIAL TOOL 6958

CAUTION: Do not exceed the minimum tightening torque when installing the pinion yoke retaining nut at this point. Damage to collapsible spacer or bearings may result.

(3) Install a new nut on the pinion gear. **Tighten the nut only enough to remove the shaft end play.**

(4) Rotate the pinion a minimum of ten times. Verify that the pinion rotates smoothly. Rotate the pinion shaft using a (in. lbs.) torque wrench. Rotating resistance torque should be equal to the reading recorded during removal, plus an additional 0.56 N-m (5 in. lbs.) (Fig. 14).

(5) If the rotating torque is low, use Holder 6958 to hold the pinion yoke (Fig. 15), and tighten the pinion shaft nut in 6.8 N-m (5 ft. lbs.) increments until proper rotating torque is achieved.

CAUTION: If the maximum tightening torque is reached prior to reaching the required rotating torque, the collapsible spacer may have been damaged. Replace the collapsible spacer.

(6) Align the installation reference marks on propeller shaft and yoke and install the propeller shaft.

(7) Add gear lubricant to the differential housing, if necessary. Refer to the Lubricant Specifications for gear lubricant requirements.

(8) Install brake rotors and calipers. Refer to Group 5, Brakes, for proper procedures.

(9) Install wheel and tire assemblies.

(10) Lower the vehicle.

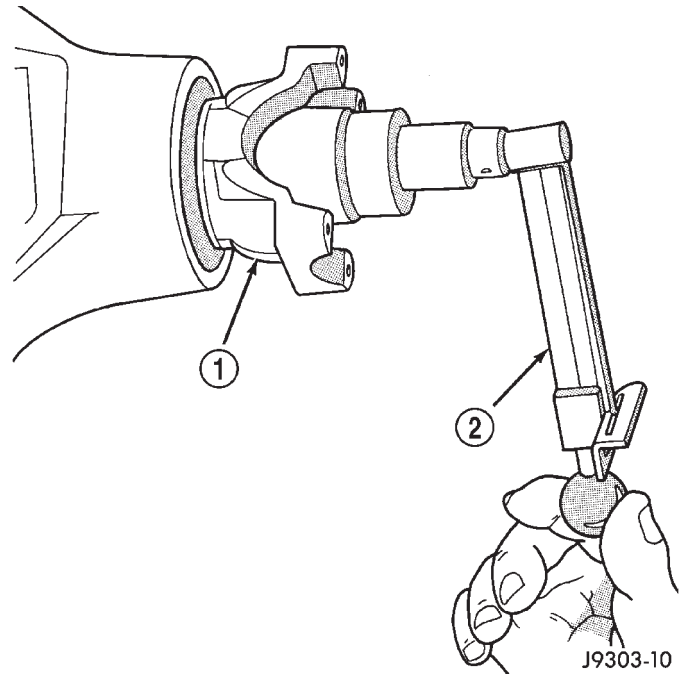

Fig. 14 Check Pinion Rotation Torque

- 1 - PINION YOKE
- 2 - INCH POUND TORQUE WRENCH

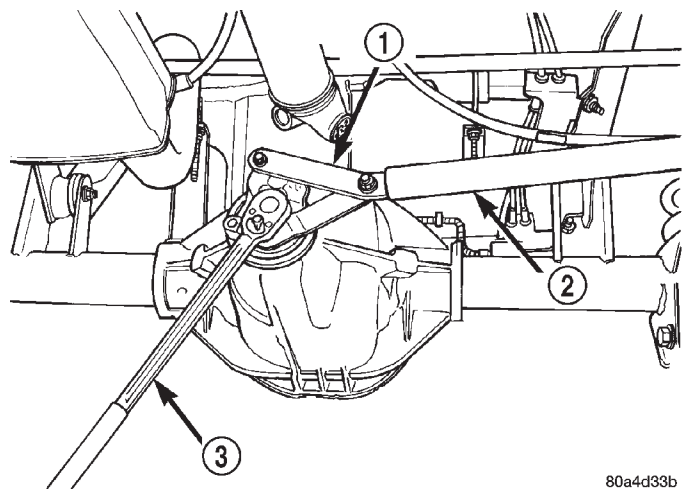

Fig. 15 Tightening Pinion Shaft Nut

- 1 - SPECIAL TOOL 6958
- 2 - 1 in. PIPE
- 3 - 3/4 DRIVE TORQUE WRENCH

COLLAPSIBLE SPACER

REMOVAL W/PINION INSTALLED

- (1) Raise and support the vehicle.
- (2) Remove wheel and tire assemblies.
- (3) Remove rear brake rotors and calipers. Refer to Group 5, Brakes, for proper procedures.
- (4) Mark the propeller shaft and pinion yoke for installation reference.

REMOVAL AND INSTALLATION (Continued)

- (5) Remove the propeller shaft from the yoke.
- (6) Rotate the pinion gear a minimum of ten times. Verify that the pinion rotates smoothly.
- (7) Measure the amount of torque necessary to rotate the pinion gear with a (in. lbs.) dial-type torque wrench. Record the torque reading for installation reference.
- (8) Using a short piece of pipe and Holder 6958 to hold the pinion yoke, remove the pinion nut and washer (Fig. 16).
- (9) Use Remover C-452 and Wrench C-3281 to remove the pinion yoke (Fig. 17).
- (10) Use Remover 7794-A and slide hammer to remove the pinion shaft seal (Fig. 18).
- (11) Remove the front pinion bearing using a pair of suitable pick tools to pull the bearing straight off the pinion gear shaft. It may be necessary to lightly tap the end of the pinion gear with a rawhide or rubber mallet if the bearing becomes bound on the pinion shaft.

(12) Remove the collapsible spacer.

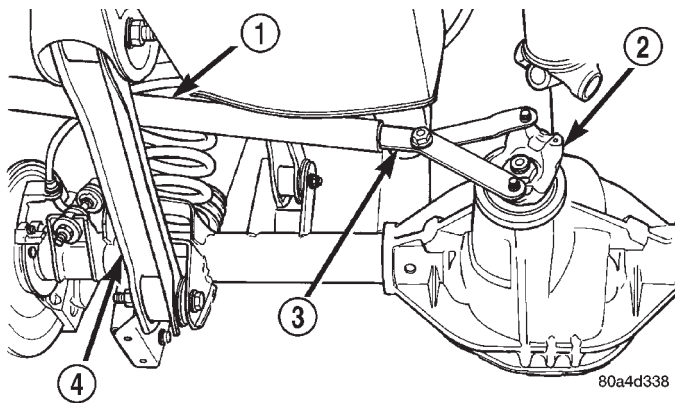

Fig. 16 Pinion Yoke Holder

- 1 - 1 in. PIPE
- 2 - PINION YOKE
- 3 - SPECIAL TOOL 6958
- 4 - LOWER CONTROL ARM

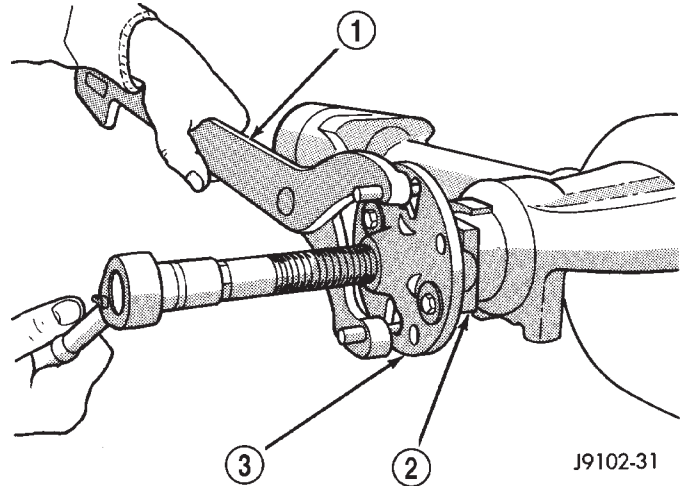

Fig. 17 Pinion Yoke Removal

- 1 - SPECIAL TOOL C-3281
- 2 - YOKE
- 3 - SPECIAL TOOL C-452

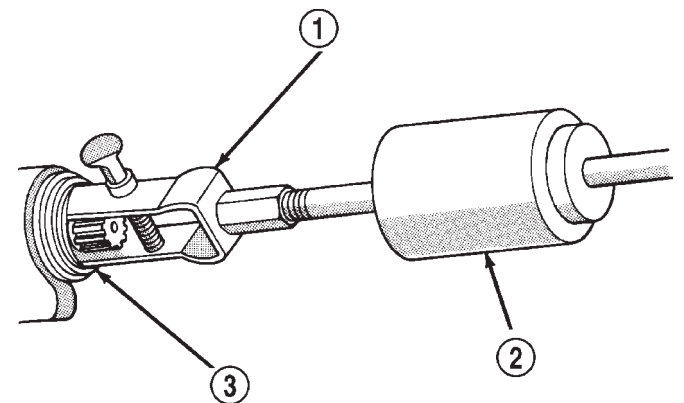

Fig. 18 Seal Removal

- 1 - SPECIAL TOOL 7794A
- 2 - SLIDE HAMMER
- 3 - PINION SEAL

REMOVAL W/PINION REMOVED

- (1) Raise and support the vehicle.
- (2) Remove wheel and tire assemblies.
- (3) Remove rear brake rotors and calipers. Refer to Group 5, Brakes, for proper procedures.
- (4) Mark the propeller shaft and pinion yoke for installation reference.
- (5) Remove the propeller shaft from the yoke.
- (6) Rotate the pinion gear a minimum of ten times. Verify that the pinion rotates smoothly.
- (7) Measure the amount of torque necessary to rotate the pinion gear with a (in. lbs.) dial-type torque wrench. Record the torque reading for installation reference.

- (8) Remove differential assembly from axle housing.
- (9) Using Holder 6958 to hold yoke and a short length of 1 in. pipe, remove the pinion yoke nut and washer (Fig. 16).
- (10) Using Remover C-452 and Wrench C-3281, remove the pinion yoke from pinion shaft (Fig. 17).
- (11) Remove the pinion gear from housing (Fig. 19). Catch the pinion with your hand to prevent it from falling and being damaged.
- (12) Remove collapsible spacer from pinion shaft.

INSTALLATION

- (1) Install a new collapsible preload spacer on pinion shaft (Fig. 20).

REMOVAL AND INSTALLATION (Continued)

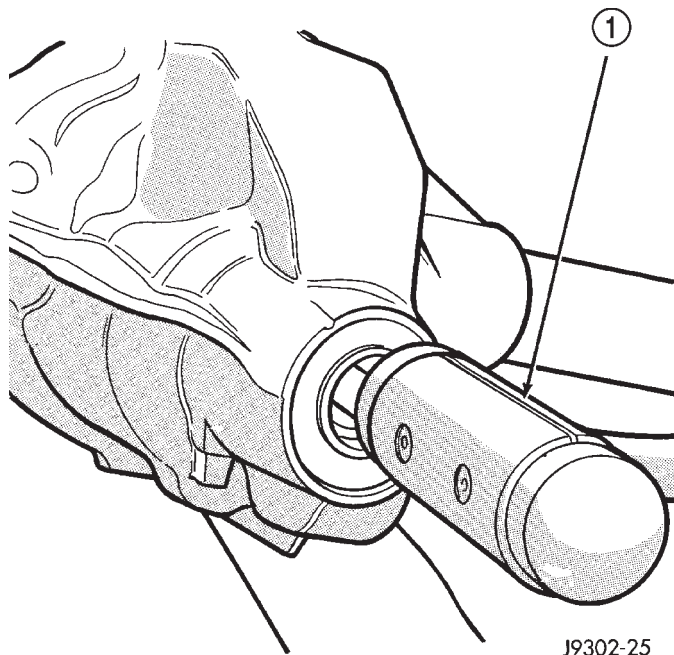

Fig. 19 Remove Pinion Gear

- 1 - RAWHIDE HAMMER

(2) If pinion gear was removed, install pinion gear in housing.

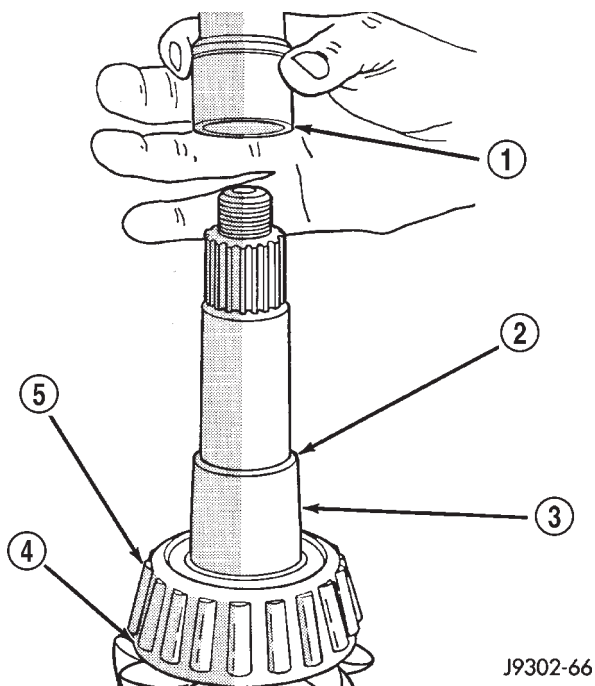
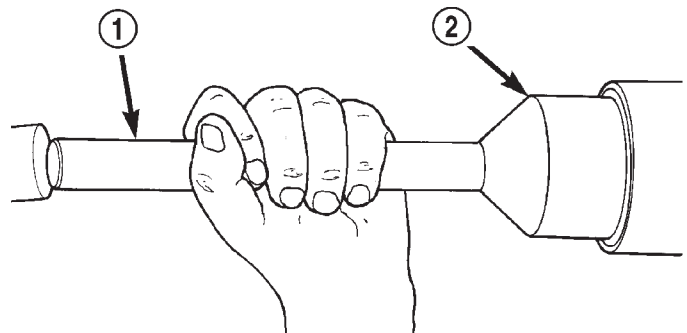

Fig. 20 Collapsible Preload Spacer

- 1 - COLLAPSIBLE SPACER
- 2 - SHOULDER
- 3 - PINION GEAR
- 4 - OIL SLINGER
- 5 - REAR BEARING

(3) Install pinion front bearing, if necessary.
 (4) Apply a light coating of gear lubricant on the lip of pinion seal. Install seal with Installer C-3972-A and Handle C-4171 (Fig. 21).



80a7e2be

Fig. 21 Pinion Seal Installation

- 1 - SPECIAL TOOL C-4171
- 2 - SPECIAL TOOL C-3972-A

(5) Install yoke with Installer C-3718 and Holder 6958 (Fig. 22).

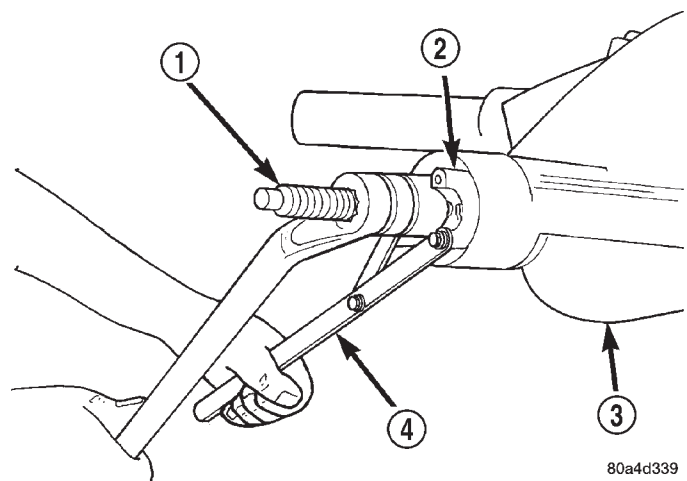

80a4d339

Fig. 22 Pinion Yoke Installation

- 1 - SPECIAL TOOL C-3718
- 2 - PINION YOKE
- 3 - AXLE HOUSING
- 4 - SPECIAL TOOL 6958

(6) If the original pinion bearings are being used, install differential assembly and axle shafts, if necessary.

NOTE: If new pinion bearings were installed, do not install the differential assembly and axle shafts until after the pinion bearing preload and rotating torque are set.

REMOVAL AND INSTALLATION (Continued)

(7) Install the yoke washer and a new nut on the pinion gear. Tighten the nut to 298 N·m (220 ft. lbs.) minimum. **Do not over-tighten.** Maximum torque is 380 N·m (280 ft. lbs.).

CAUTION: Never loosen pinion gear nut to decrease pinion gear bearing rotating torque and never exceed specified preload torque. If preload torque is exceeded a new collapsible spacer must be installed. The torque sequence will then have to be repeated.

NOTE: If the spacer requires more than 280 ft. lbs. torque to crush, the collapsible spacer is defective.

(8) Using yoke holder 6958, a short length of 1 in. pipe, and a torque wrench set at 380 N·m (280 ft. lbs.), crush collapsible spacer until bearing end play is taken up (Fig. 23).

(9) Slowly tighten the nut in 6.8 N·m (5 ft. lbs.) increments until the required rotating torque is achieved. Measure the rotating torque frequently to avoid over crushing the collapsible spacer (Fig. 24).

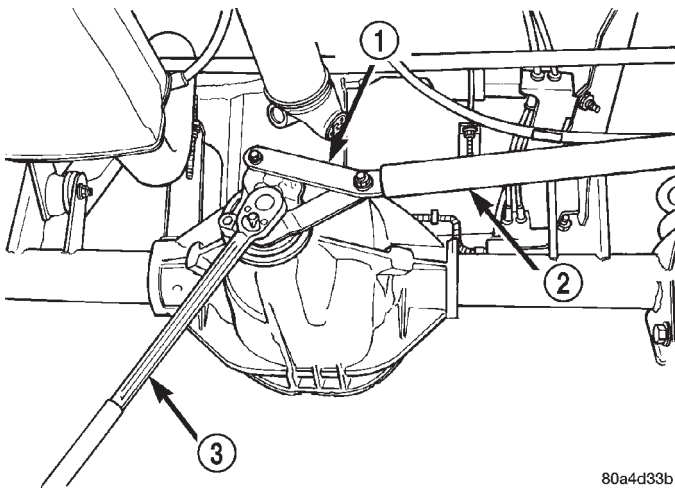

Fig. 23 Tightening Pinion Nut

- 1 - SPECIAL TOOL 6958
- 2 - 1 in. PIPE
- 3 - 3/4 DRIVE TORQUE WRENCH

(10) Rotate the pinion a minimum of ten times. Verify that the pinion rotates smoothly. Check rotating torque with an inch pound torque wrench (Fig. 24). The torque necessary to rotate the pinion gear should be:

- Original Bearings — The reading recorded during removal, plus an additional 0.56 N·m (5 in. lbs.).
- New Bearings — 2.8 to 4 N·m (25 to 35 in. lbs.).

(11) Install differential assembly and axle shafts, if necessary.

(12) Align marks made previously on yoke and propeller shaft and install propeller shaft.

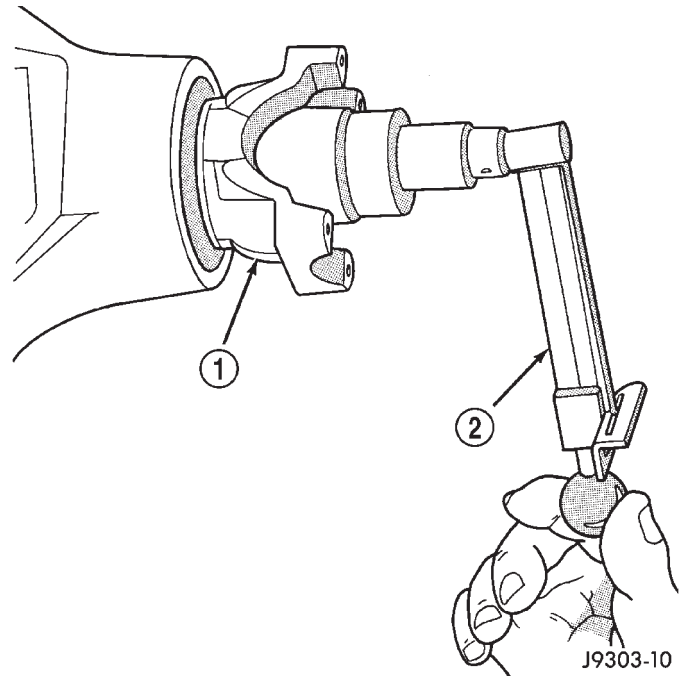

Fig. 24 Check Pinion Gear Rotation Torque

- 1 - PINION YOKE
- 2 - INCH POUND TORQUE WRENCH

(13) Install rear brake rotors and calipers. Refer to Group 5 Brakes, for proper procedures.

(14) Add gear lubricant, if necessary. Refer to Lubricant Specifications of this section for lubricant requirements.

(15) Install wheel and tire assemblies.

(16) Lower vehicle.

AXLE SHAFT

REMOVAL

(1) Raise and support vehicle. Ensure that the transmission is in neutral.

(2) Remove wheel and tire assembly.

(3) Remove brake caliper and rotor. Refer to Group 5, Brakes, for proper procedure.

(4) From the rear of the axle flange, remove the nuts holding axle retainer plate to axle tube.

(5) Using Slide Hammer 7420, Adapter 6790, and suitable lug nuts, pull axle shaft from vehicle.

NOTE: It is normal that the axle bearing race is loose in the axle tube.

INSTALLATION

(1) Insert axle into opening at end of axle tube.

(2) Align flat area on axle shaft retaining plate upward.

REMOVAL AND INSTALLATION (Continued)

(3) Insert the retaining plate studs into the brake backing plate and the axle tube flange.

(4) Install nuts to hold axle retaining plate to axle tube. Tighten the nuts to 61 N·m (45 ft. lbs.).

(5) Install brake caliper and rotor. Refer to Group 5, Brakes, for proper procedures.

(6) Install wheel and tire.

(7) Check and fill the gear lubricant. Refer to the Lubricant Specifications for gear lubricant requirements.

(8) Lower vehicle.

AXLE SHAFT SEAL AND BEARING

REMOVAL

(1) Remove axle shaft from vehicle.

NOTE: It is normal that the axle bearing race is loose in the axle tube.

(2) Remove the studs from the axle retaining plate.

(3) Using a 3/8 in. dia. drill bit, drill a shallow hole into soft steel axle bearing retaining ring (Fig. 25). If possible, use a drill depth stop to avoid marking axle.

(4) Using a suitable cold chisel, cut retaining ring across drilled hole. (Fig. 26)

(5) Slide retaining ring from axle shaft.

(6) Using Splitter 1130 placed between the seal and bearing and a suitable Arbor Press, press bearing from the axle shaft (Fig. 27).

(7) Slide seal from axle.

(8) Slide retaining plate from axle shaft.

INSTALLATION

(1) Using a suitable straight edge, verify flatness of axle shaft retaining plate. Replace plate if warped.

(2) Install the studs back into the retaining plate. If the studs are loose in the plate, replace the retaining plate.

(3) Install retaining plate on axle (Fig. 28).

(4) Apply a coat of multi-purpose grease on sealing surface of axle seal.

(5) Install seal on axle with cavity away from retaining plate (Fig. 28).

(6) Lubricate bearing with Mopar® Wheel Bearing Grease, or equivalent. Wipe excess grease from the bearing.

(7) Slide bearing onto axle shaft (Fig. 28).

(8) Using Installer 7913 and shop press, press bearing onto axle shaft (Fig. 29).

(9) Using Installer 7913 and shop press, press soft metal retaining ring onto axle shaft (Fig. 30).

(10) Install axle in vehicle.

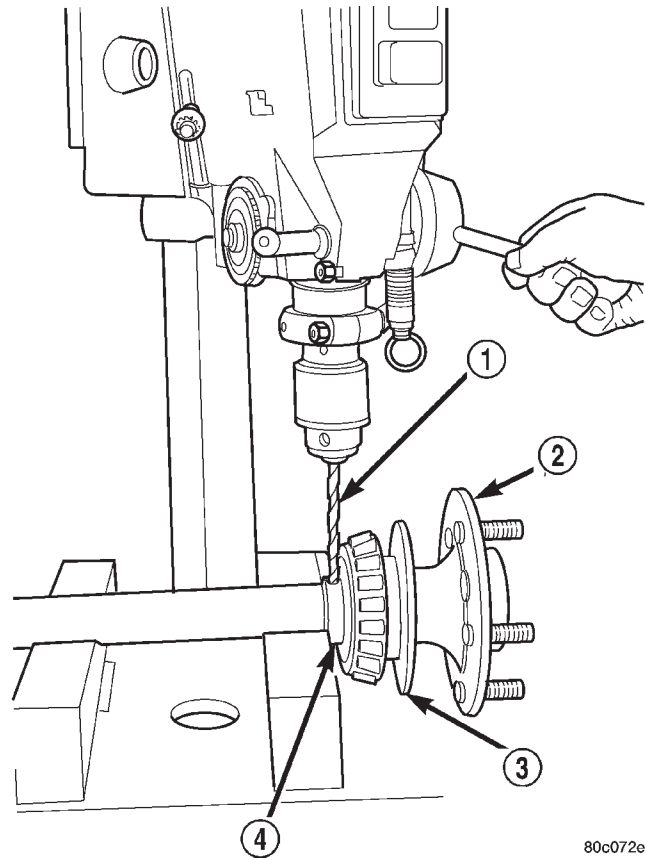

80c072eb

Fig. 25 Drill Retaining Ring

- 1 - 3/8 IN DIA DRILL BIT
- 2 - AXLE
- 3 - RETAINING PLATE
- 4 - SOFT METAL RETAINING RING

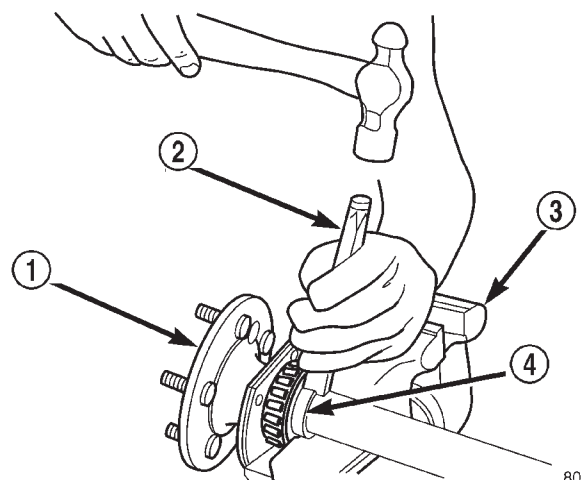

80c072ec

Fig. 26 Cut Retaining Ring

- 1 - AXLE
- 2 - COLD CHISEL
- 3 - VISE
- 4 - RETAINING RING

REMOVAL AND INSTALLATION (Continued)

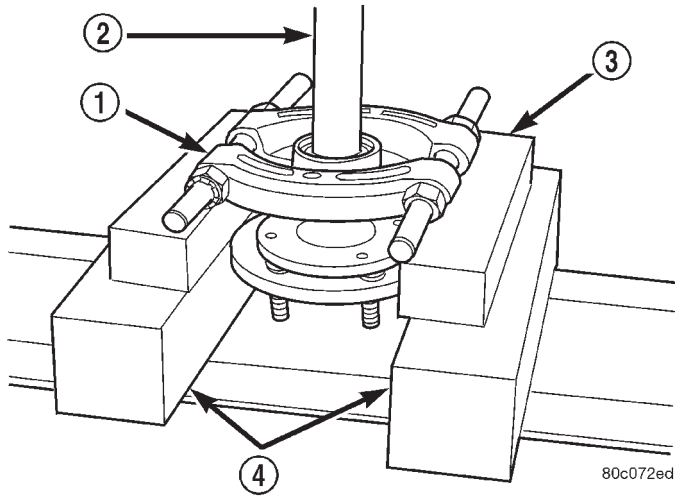

Fig. 27 Axle Bearing and Seal Remove

- 1 - AXLE
- 2 - PRESS PLATES
- 3 - BLOCKS
- 4 - SPECIAL TOOL 1130

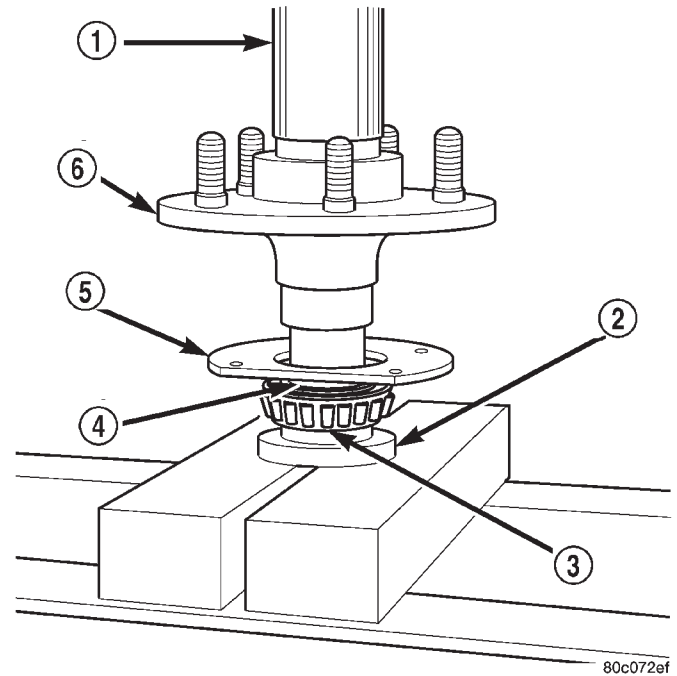

Fig. 29 Press Bearing Onto Axle

- 1 - PRESS RAM
- 2 - SPECIAL TOOL 7913
- 3 - AXLE BEARING
- 4 - SEAL
- 5 - RETAINING PLATE
- 6 - AXLE

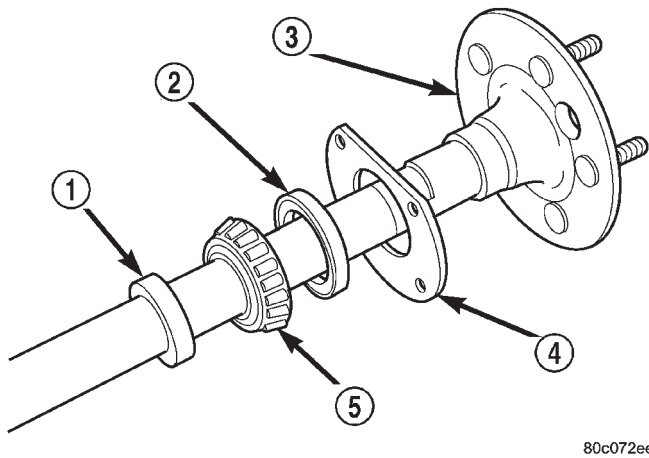

Fig. 28 Axle Bearing and Seal Components

- 1 - RETAINING RING
- 2 - SEAL
- 3 - AXLE
- 4 - RETAINING PLATE
- 5 - AXLE BEARING

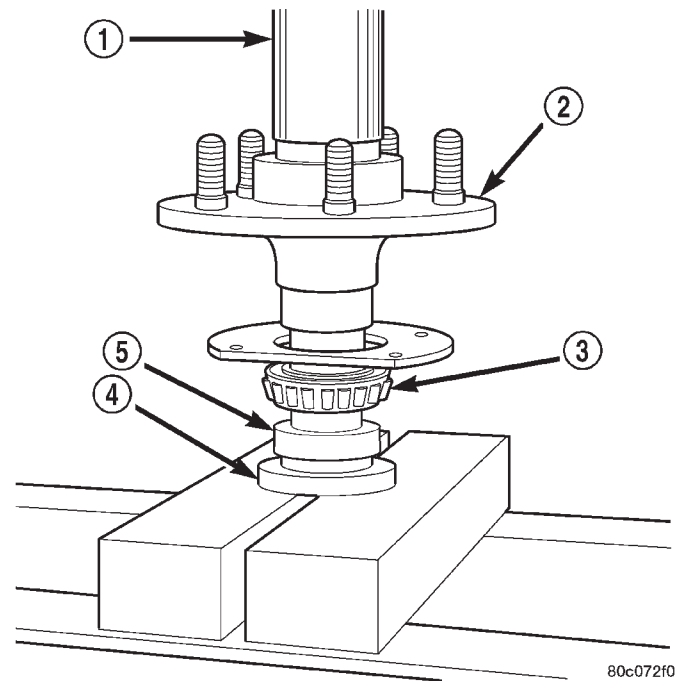

Fig. 30 Press Bearing Retaining Ring On Axle

- 1 - PRESS RAM
- 2 - AXLE
- 3 - AXLE BEARING
- 4 - SPECIAL TOOL 7913
- 5 - SOFT METAL RETAINING RING

REMOVAL AND INSTALLATION (Continued)

DIFFERENTIAL

REMOVAL

- (1) Raise and support vehicle.
- (2) Remove the lubricant fill hole plug from the differential housing cover.
- (3) Remove the differential housing cover and allow fluid to drain.
- (4) Remove axle shafts.
- (5) Note the installation reference letters stamped on the bearing caps and housing machined sealing surface (Fig. 31).

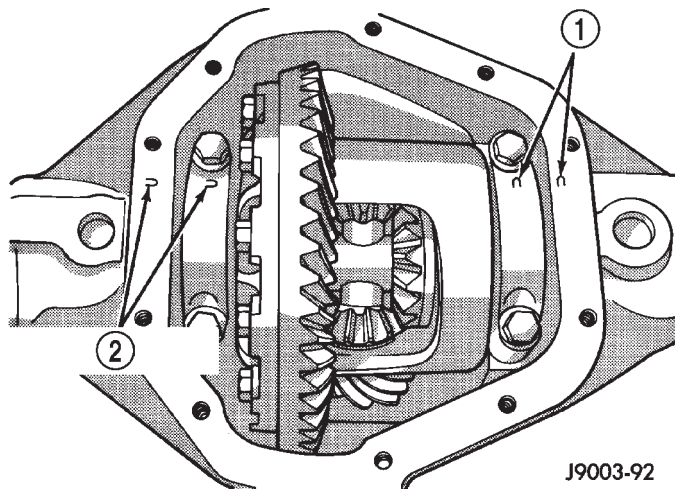

J9003-92

Fig. 31 Bearing Cap Identification

- 1 - INSTALLATION REFERENCE LETTERS
- 2 - INSTALLATION REFERENCE LETTERS

- (6) Loosen the differential bearing cap bolts.
- (7) Position Spreader W-129-B, utilizing some items from Adapter set 6987, with the tool dowel pins seated in the locating holes (Fig. 32). Install the hold-down clamps and tighten the tool turnbuckle finger-tight.
- (8) Install a Pilot Stud C-3288-B at the left side of the differential housing. Attach Dial Indicator C-3339 to pilot stud. Load the indicator plunger against the opposite side of the housing (Fig. 33) and zero the indicator.

CAUTION: Do not spread over 0.38 mm (0.015 in). If the housing is over-spread, it could be distorted or damaged.

- (9) Spread the housing enough to remove the differential case from the housing. Measure the distance with the dial indicator (Fig. 34).

- (10) Remove the dial indicator.

- (11) While holding the differential case in position, remove the differential bearing cap bolts and caps.

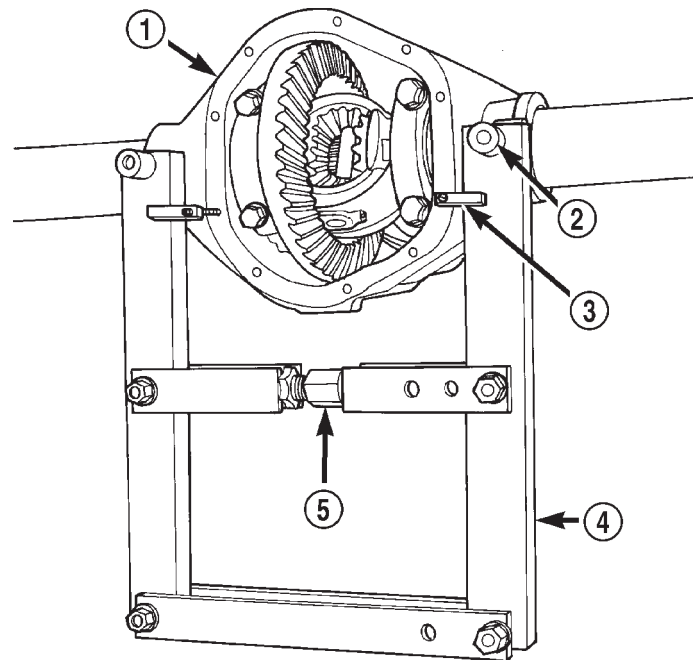

80a534c5

Fig. 32 Install Axle Housing Spreader

- 1 - AXLE HOUSING
- 2 - DOWEL
- 3 - SAFETY HOLD DOWN
- 4 - SPECIAL TOOL W-129-B
- 5 - TURNBUCKLE

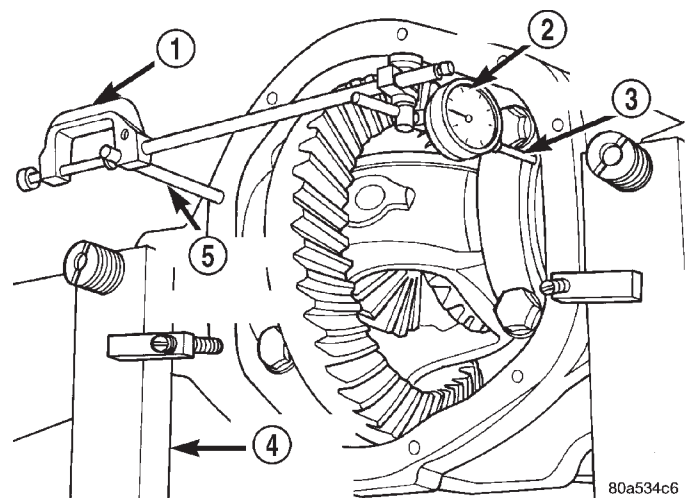

80a534c6

Fig. 33 Install Dial Indicator

- 1 - SPECIAL TOOL C-3339
- 2 - DIAL INDICATOR
- 3 - LEVER ADAPTER
- 4 - SPECIAL TOOL W-129-B
- 5 - SPECIAL TOOL C-3288-B

- (12) Remove the differential from the housing. Ensure that the differential bearing cups remain in position on the differential bearings (Fig. 35).

REMOVAL AND INSTALLATION (Continued)

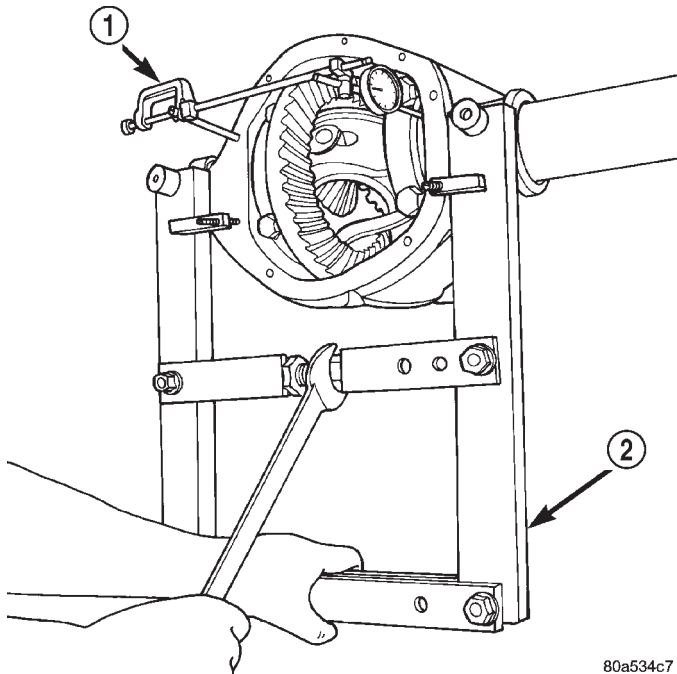

80a534c7

Fig. 34 Spread Axle Housing

- 1 - SPECIAL TOOL C-3339
- 2 - SPECIAL TOOL W-129-B

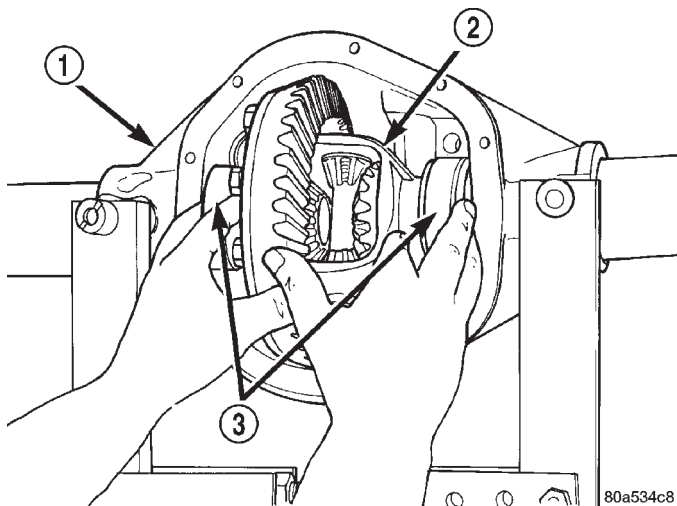

80a534c8

Fig. 35 Differential Case Removal

- 1 - AXLE HOUSING
- 2 - DIFFERENTIAL CASE
- 3 - BEARING CUPS

(13) Mark or tag the differential bearing cups to indicate which side of the differential they were removed from.

(14) Retrieve differential case preload shims from axle housing. Mark or tag the differential case preload shims to indicate which side of the differential they were removed from.

(15) Remove spreader from housing.

INSTALLATION

If replacement differential bearings or differential case are being installed, differential side bearing shim requirements may change. Refer to the Differential Bearing Preload and Gear Backlash procedures in this section to determine the proper shim selection.

(1) Position Spreader W-129-B, utilizing some items from Adapter set 6987, with the tool dowel pins seated in the locating holes (Fig. 36). Install the hold-down clamps and tighten the tool turnbuckle finger-tight.

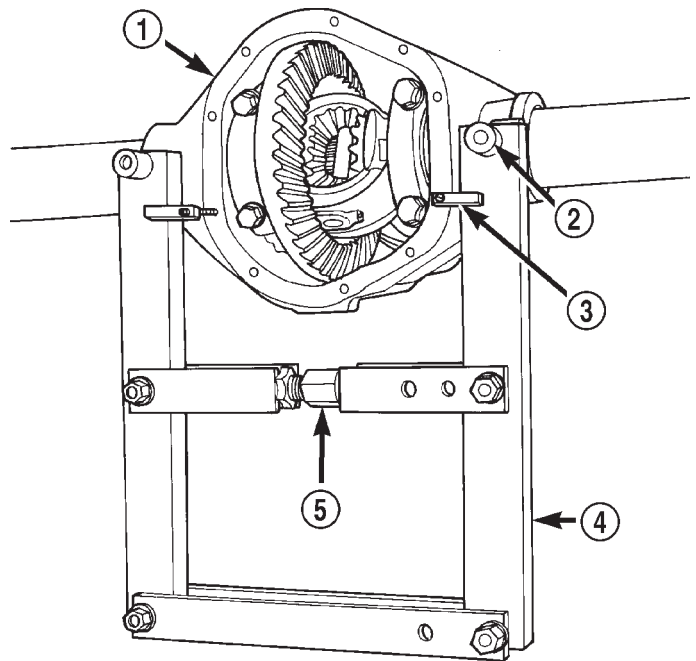

80a534c5

Fig. 36 Install Axle Housing Spreader

- 1 - AXLE HOUSING
- 2 - DOWEL
- 3 - SAFETY HOLD DOWN
- 4 - SPECIAL TOOL W-129-B
- 5 - TURNBUCKLE

(2) Install a Pilot Stud C-3288-B at the left side of the differential housing. Attach Dial Indicator C-3339 to pilot stud. Load the indicator plunger against the opposite side of the housing (Fig. 33) and zero the indicator.

CAUTION: Do not spread over 0.38 mm (0.015 in). If the housing is over-spread, it could be distorted or damaged.

(3) Spread the housing enough to install the case in the housing. Measure the distance with the dial indicator (Fig. 34).

(4) Remove the dial indicator.

REMOVAL AND INSTALLATION (Continued)

(5) Install differential case in the housing. Ensure that the differential bearing cups remain in position on the differential bearings and that the preload shims remain between the face of the bearing cup and the housing. Also verify that the pick-up opening of the Vari-lok™ plenum is at the bottom of the housing. Tap the differential case to ensure the bearings and shims are fully seated in the housing.

(6) Install the bearing caps at their original locations (Fig. 37).

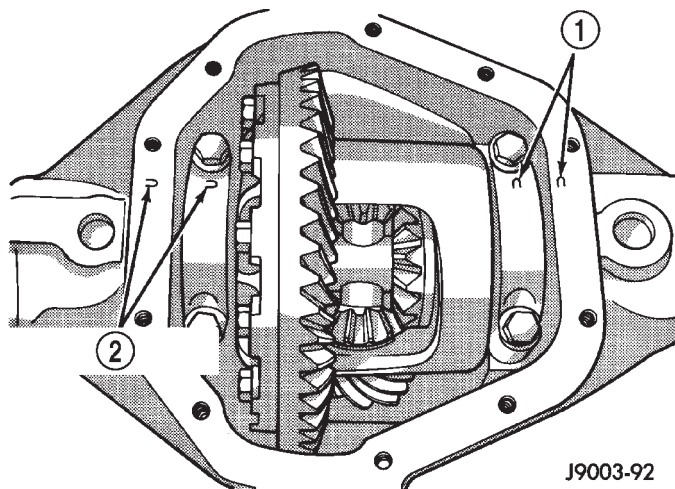

Fig. 37 Differential Bearing Cap Reference Letters

- 1 - INSTALLATION REFERENCE LETTERS
2 - INSTALLATION REFERENCE LETTERS

- (7) Loosely install differential bearing cap bolts.
(8) Remove axle housing spreader.
(9) Tighten the bearing cap bolts to 77 N·m (57 ft. lbs.) torque.
(10) Install the axle shafts.

DIFFERENTIAL SIDE BEARINGS

REMOVAL

- (1) Remove differential case from axle housing.
(2) Remove the bearings from the differential case with Puller/Press C-293-PA, Adapters 8353, and Plug C-293-3 (Fig. 38).

INSTALLATION

If replacement differential side bearings or differential case are being installed, differential side bearing shim requirements may change. Refer to the Differential Bearing Preload and Gear Backlash procedures in this section to determine the proper shim selection.

CAUTION: Be sure that the Vari-lok™ plenum is fully seated against the differential case prior to installing the ring gear side differential bearing.

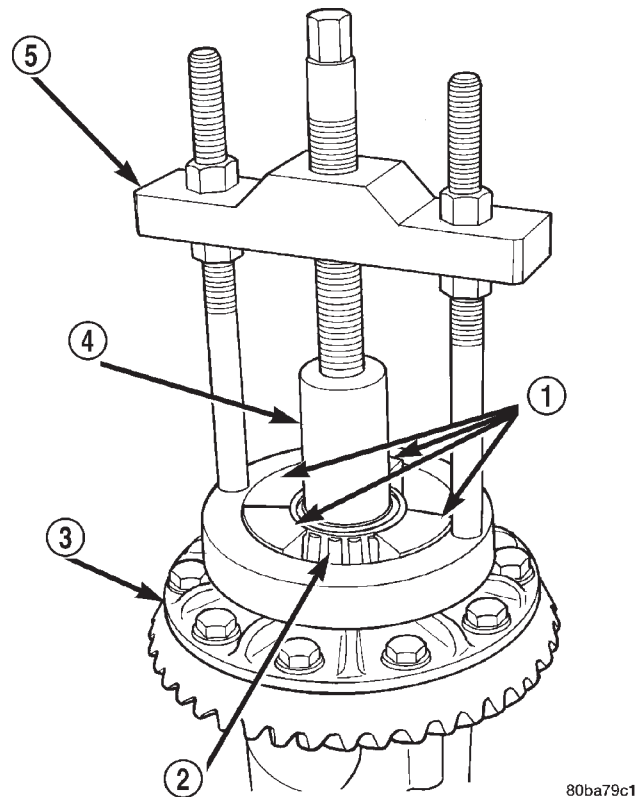

Fig. 38 Differential Bearing Removal

- 1 - SPECIAL TOOL 8353
2 - BEARING
3 - DIFFERENTIAL
4 - SPECIAL TOOL C-293-3
5 - SPECIAL TOOL C-293-PA

- (1) Using tool C-4340 with handle C-4171, install differential side bearings (Fig. 39).
(2) Install differential case in axle housing.

VARI-LOK™ PLENUM

REMOVAL

- (1) Remove differential case from axle housing.
(2) Remove the bearing from the ring gear side of the differential case with Puller/Press C-293-PA, Adapter Blocks 8353, and Plug C-293-3 (Fig. 40).
(3) Remove the Vari-lok™ plenum from the differential case hub.

WARNING: Do not touch the Vari-lok™ tuning reed valve located under the Vari-lok™ plenum on the differential case. The metal is very sensitive and the unit will not operate properly if the reed valve is disturbed.

INSTALLATION

If a replacement differential side bearing is being installed, differential side bearing shim requirements

REMOVAL AND INSTALLATION (Continued)

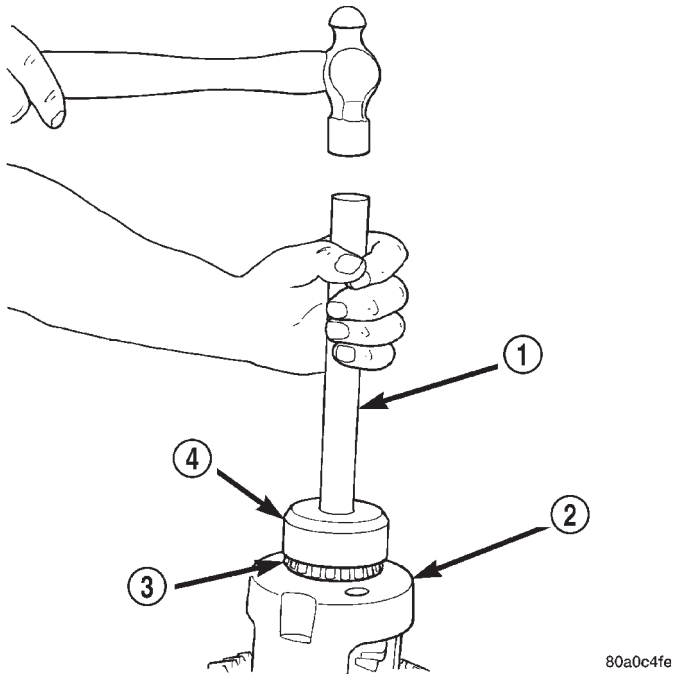

Fig. 39 Install Differential Side Bearings

- 1 - HANDLE C-4171
- 2 - DIFFERENTIAL
- 3 - BEARING
- 4 - TOOL C-4340

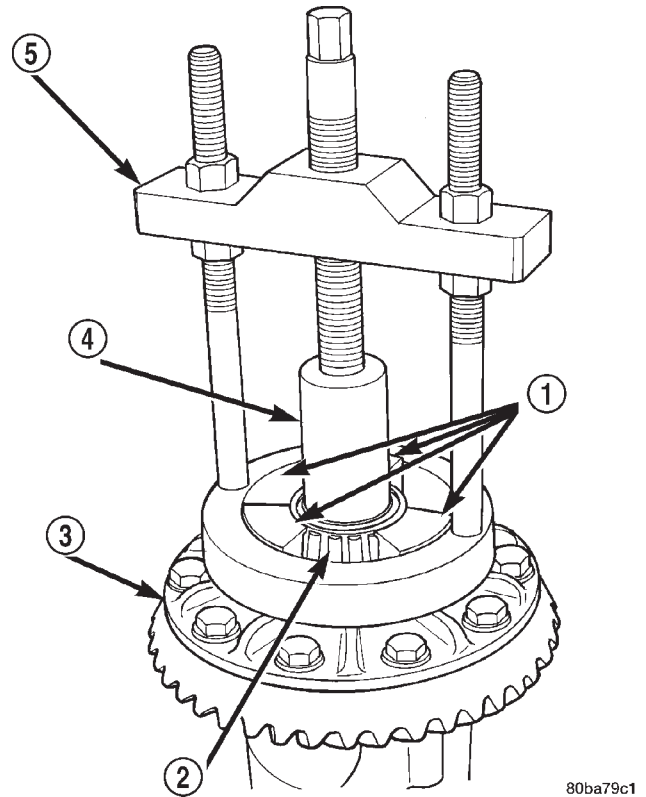

Fig. 40 Differential Bearing Removal

- 1 - SPECIAL TOOL 8353
- 2 - BEARING
- 3 - DIFFERENTIAL
- 4 - SPECIAL TOOL C-293-3
- 5 - SPECIAL TOOL C-293-PA

may change. Refer to the Differential Bearing Preload and Gear Backlash procedures in this section to determine the proper shim selection.

(1) Install a new Vari-lok™ plenum onto the differential case hub. The plenum is to be installed with the rubber seal toward the differential case and the raised metal tabs away from the differential case.

CAUTION: Be sure that the Vari-lok™ plenum is fully seated against the differential case prior to installing the ring gear side differential bearing.

- (2) Using Installer C-4340 and Handle C-4171, install differential side bearing (Fig. 41).
- (3) Install differential in axle housing.

RING GEAR

NOTE: The ring and pinion gears are serviced as a matched set. Do not replace the ring gear without replacing the pinion gear.

REMOVAL

- (1) Remove differential from axle housing.
- (2) Place differential case in a suitable vise with soft metal jaw protectors. (Fig. 42)
- (3) Remove bolts holding ring gear to differential case.

(4) Using a soft hammer, drive ring gear from differential case (Fig. 42).

INSTALLATION

CAUTION: Do not reuse the bolts that held the ring gear to the differential case. The bolts can fracture causing extensive damage.

- (1) Invert the differential case and start two ring gear bolts. This will provide case-to-ring gear bolt hole alignment.
- (2) Invert the differential case in the vise.
- (3) Install new ring gear bolts and alternately tighten to 95–122 N·m (70–90 ft. lbs.) torque (Fig. 43).
- (4) Install differential in axle housing and verify gear mesh and contact pattern.

PINION GEAR

NOTE: The ring and pinion gears are serviced as a matched set. Do not replace the pinion gear without replacing the ring gear.

REMOVAL AND INSTALLATION (Continued)

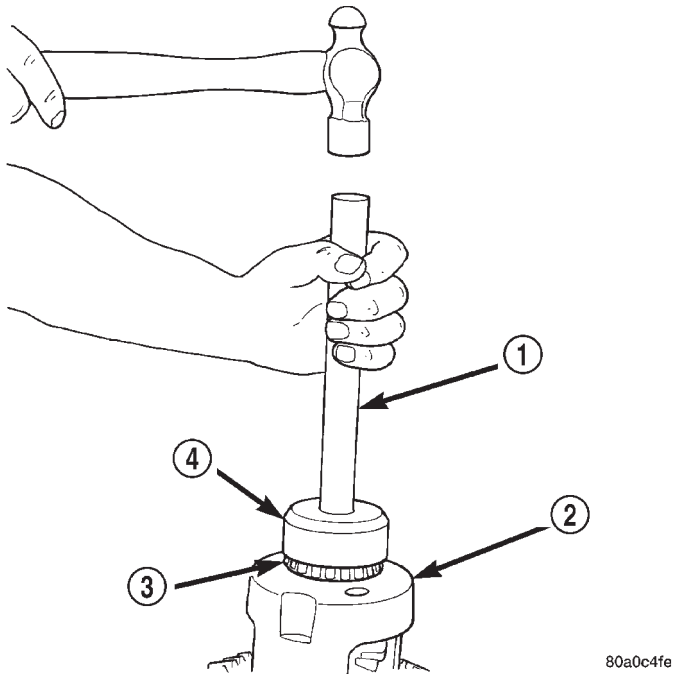

Fig. 41 Differential Side Bearing Installation

- 1 - HANDLE C-4171
- 2 - DIFFERENTIAL
- 3 - BEARING
- 4 - TOOL C-4340

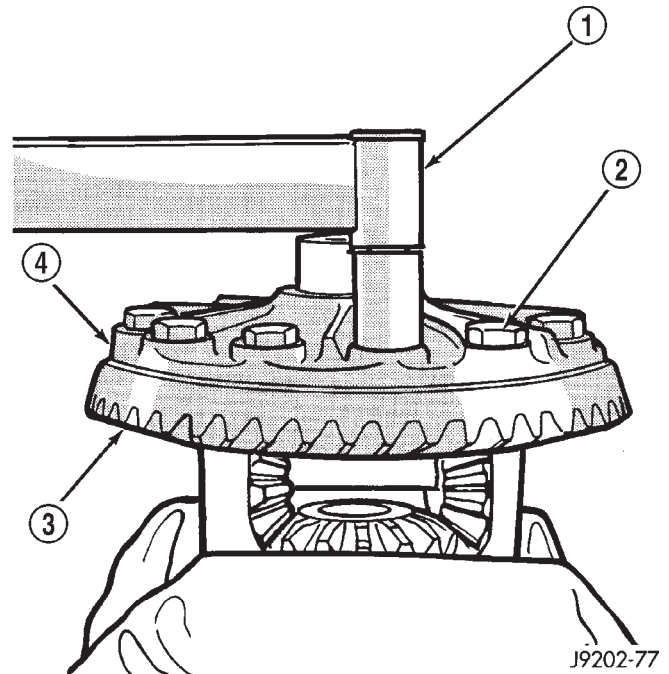

Fig. 43 Ring Gear Bolt Installation

- 1 - TORQUE WRENCH
- 2 - RING GEAR BOLT
- 3 - RING GEAR
- 4 - CASE

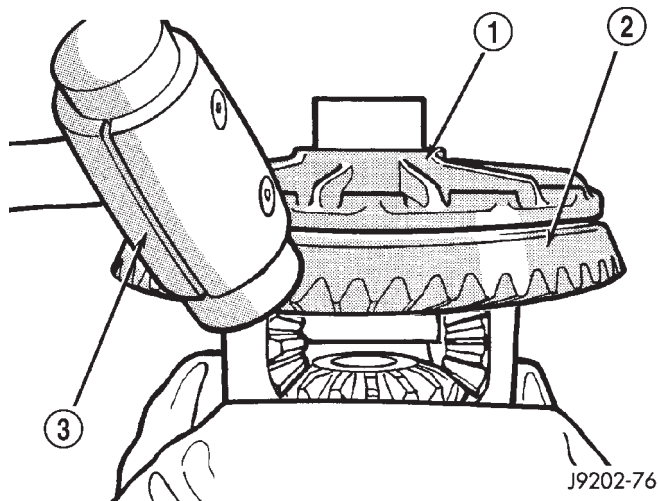

Fig. 42 Ring Gear Removal

- 1 - CASE
- 2 - RING GEAR
- 3 - RAWHIDE HAMMER

REMOVAL

- (1) Remove differential assembly from axle housing.
- (2) Mark pinion yoke and propeller shaft for installation alignment.

- (3) Disconnect propeller shaft from pinion yoke. Using suitable wire, tie propeller shaft to underbody.
- (4) Using Holder 6958 to hold yoke and a short length of 1 in. pipe, remove the pinion yoke nut and washer (Fig. 44).
- (5) Using Remover C-452 and Wrench C-3281, remove the pinion yoke from pinion shaft (Fig. 45).

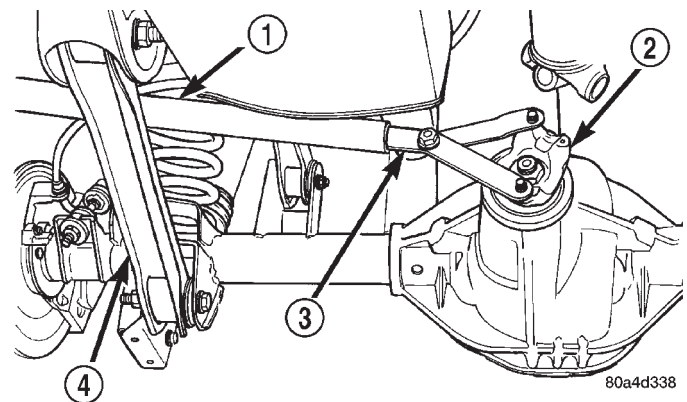

Fig. 44 Pinion Yoke Holder

- 1 - 1 in. PIPE
- 2 - PINION YOKE
- 3 - SPECIAL TOOL 6958
- 4 - LOWER CONTROL ARM

REMOVAL AND INSTALLATION (Continued)

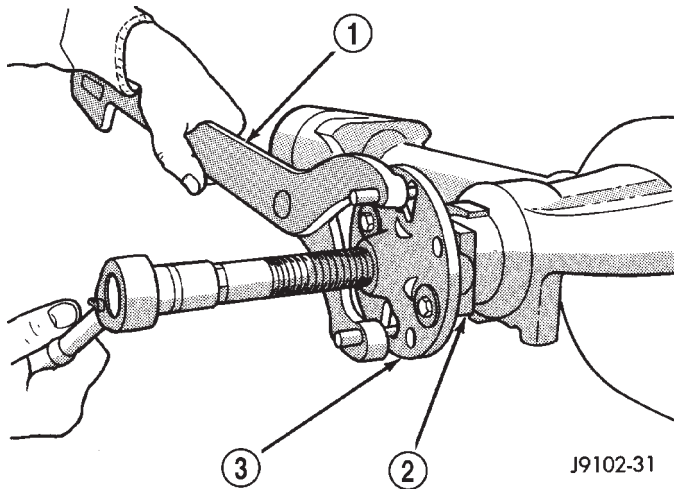

Fig. 45 Pinion Yoke Removal

- 1 - SPECIAL TOOL C-3281
- 2 - YOKE
- 3 - SPECIAL TOOL C-452

(6) Remove the pinion gear from housing (Fig. 46). Catch the pinion with your hand to prevent it from falling and being damaged.

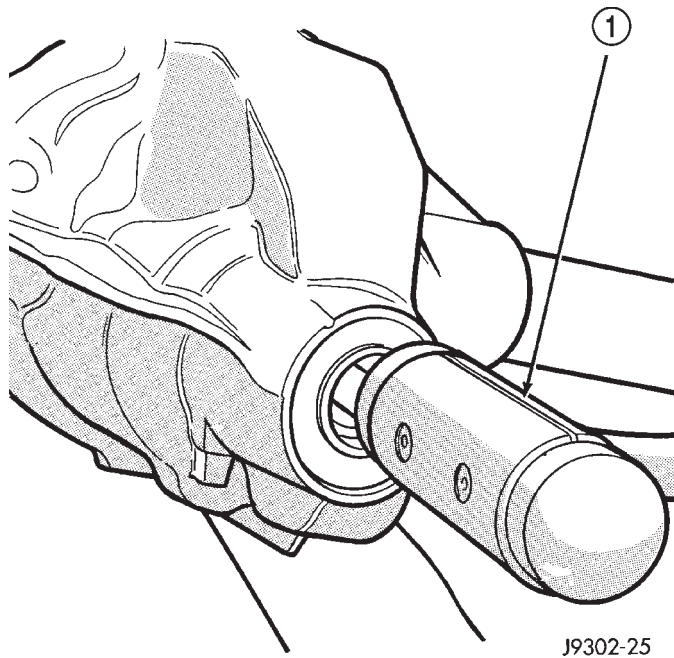

Fig. 46 Remove Pinion Gear

- 1 - RAWHIDE HAMMER

(7) Remove the pinion seal with a slide hammer or pry out with bar.

(8) Remove oil slinger, if equipped, and the front pinion bearing.

(9) Remove the front pinion bearing cup with Remover D-103 and Handle C-4171 (Fig. 47).

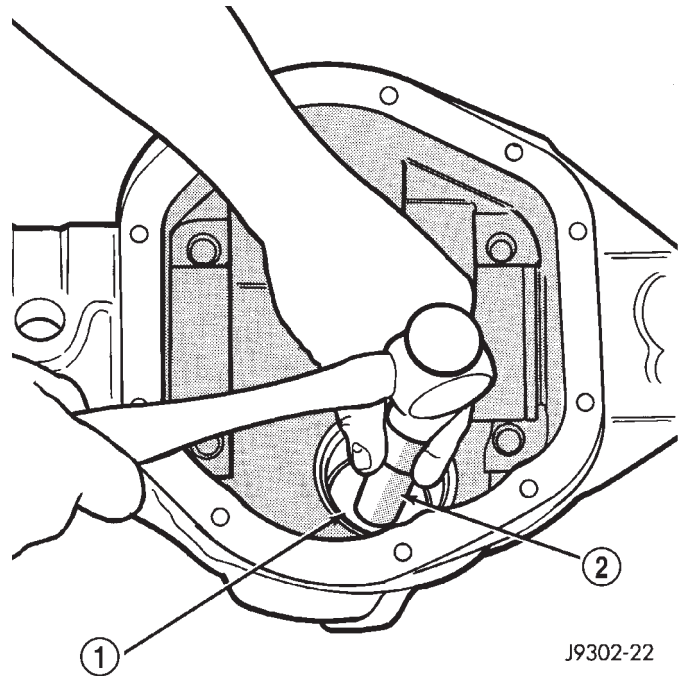

Fig. 47 Front Bearing Cup Removal

- 1 - REMOVER
- 2 - HANDLE

(10) Remove the rear bearing cup from housing (Fig. 48). Use Remover C-4307 and Handle C-4171.

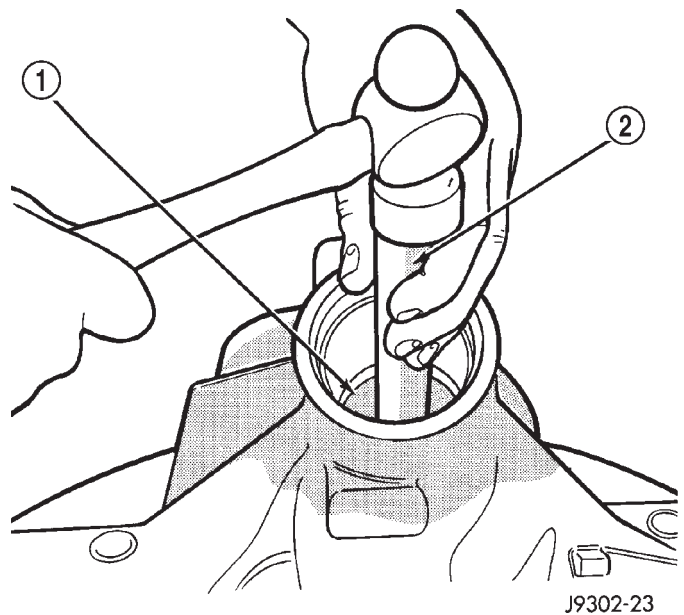

Fig. 48 Rear Bearing Cup Removal

- 1 - DRIVER
- 2 - HANDLE

REMOVAL AND INSTALLATION (Continued)

(11) Remove the collapsible preload spacer (Fig. 49).

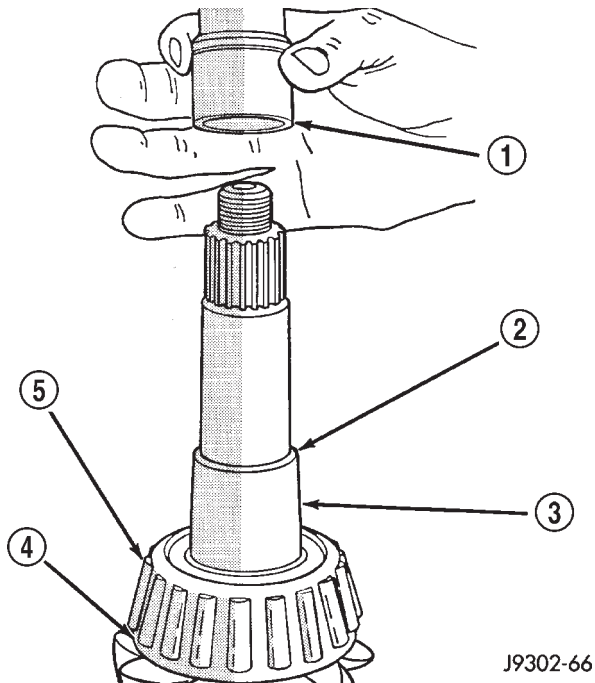

Fig. 49 Collapsible Spacer

- 1 - COLLAPSIBLE SPACER
- 2 - SHOULDER
- 3 - PINION GEAR
- 4 - OIL SLINGER
- 5 - REAR BEARING

(12) Remove the rear bearing from the pinion with Puller/Press C-293-PA and Adapters C-293-42 (Fig. 50).

Place 4 adapter blocks so they do not damage the bearing cage.

(13) Remove the pinion depth shims from the pinion gear shaft. Record the total thickness of the depth shims.

INSTALLATION

(1) Apply Mopar® Dry Film Lubricant to outside surface of bearing cup. Install the pinion rear bearing cup with Installer C-4308 and Driver Handle C-4171 (Fig. 51). Ensure cup is correctly seated.

(2) Apply Mopar® Dry Film Lubricant to outside surface of bearing cup. Install the pinion front bearing cup with Installer D-129 and Handle C-4171 (Fig. 52).

(3) Install pinion front bearing and oil slinger, if equipped. Apply a light coating of gear lubricant on the lip of pinion seal. Install seal with Installer C-3972-A and Handle C-4171 (Fig. 53).

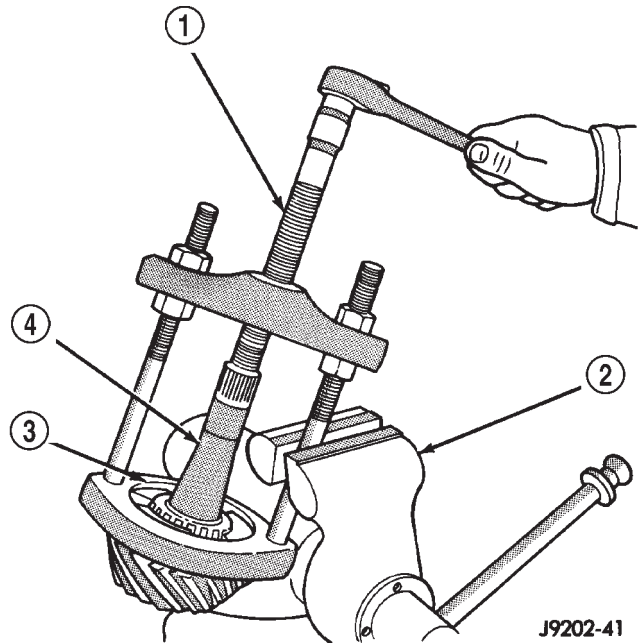

Fig. 50 Inner Bearing Removal

- 1 - SPECIAL TOOL C-293-PA
- 2 - VISE
- 3 - ADAPTERS
- 4 - DRIVE PINION GEAR SHAFT

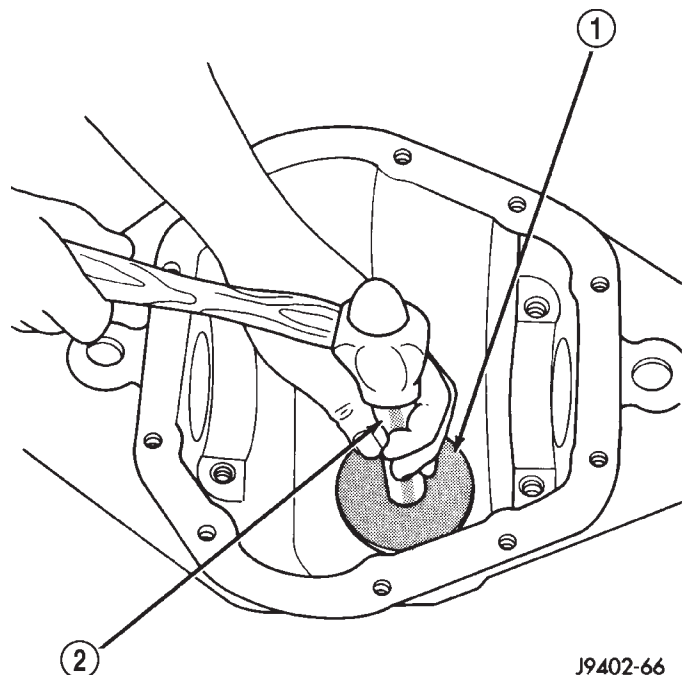

Fig. 51 Pinion Rear Bearing Cup Installation

- 1 - INSTALLER
- 2 - HANDLE

REMOVAL AND INSTALLATION (Continued)

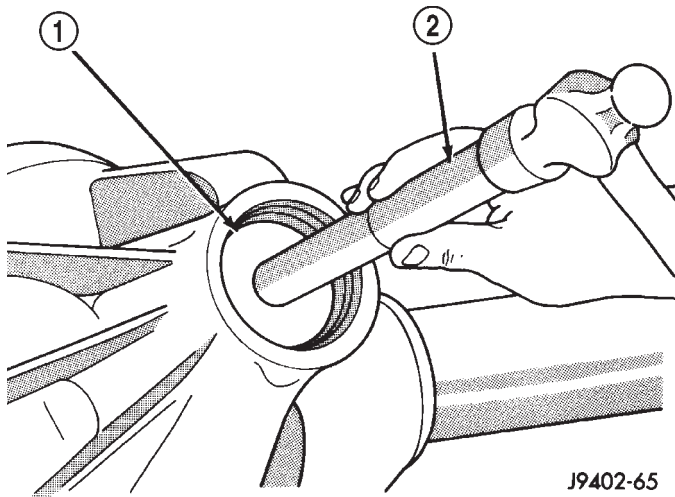

Fig. 52 Pinion Front Bearing Cup Installation

- 1 - INSTALLER
- 2 - HANDLE

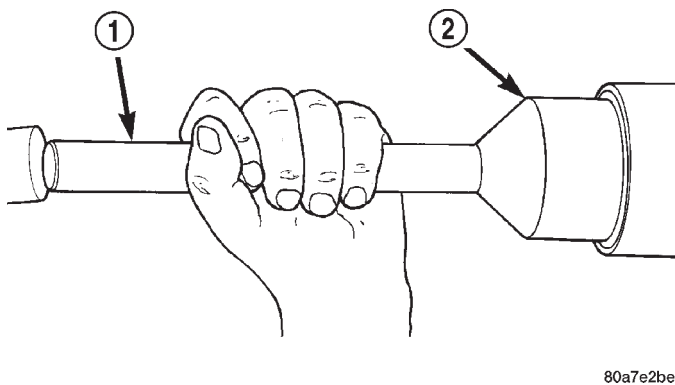

Fig. 53 Pinion Seal Installation

- 1 - SPECIAL TOOL C-4171
- 2 - SPECIAL TOOL C-3972-A

NOTE: Pinion depth shims are placed between the rear pinion bearing cone and pinion gear to achieve proper ring and pinion gear mesh. If the factory installed ring and pinion gears are reused, the pinion depth shim should not require replacement or adjustment. Refer to Pinion Gear Depth paragraph in this section to select the proper thickness shim before installing rear pinion bearing cone.

(4) Place the proper thickness pinion depth shim on the pinion gear.

(5) Install the rear bearing (and slinger if used) on the pinion gear with Installer 6448 (Fig. 54).

(6) Install a new collapsible preload spacer on pinion shaft (Fig. 55).

(7) Install pinion gear in housing.

(8) Install yoke with Installer C-3718 and holder 6958 (Fig. 56).

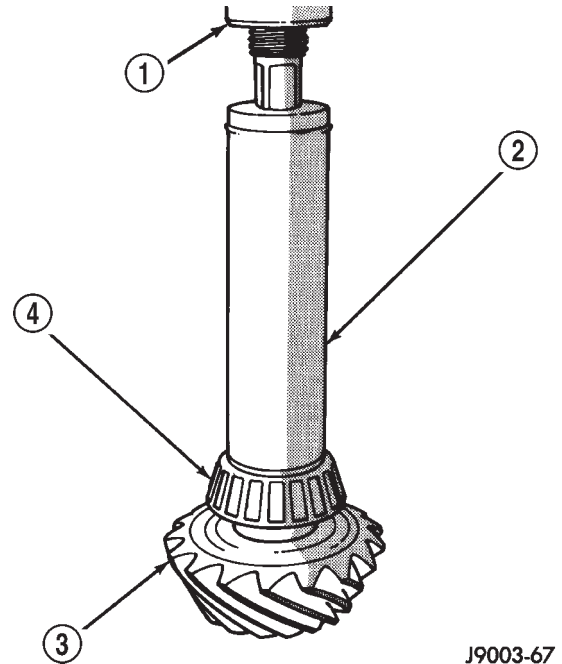

Fig. 54 Shaft Rear Bearing Installation

- 1 - PRESS
- 2 - INSTALLATION TOOL
- 3 - DRIVE PINION GEAR
- 4 - DRIVE PINION GEAR SHAFT REAR BEARING

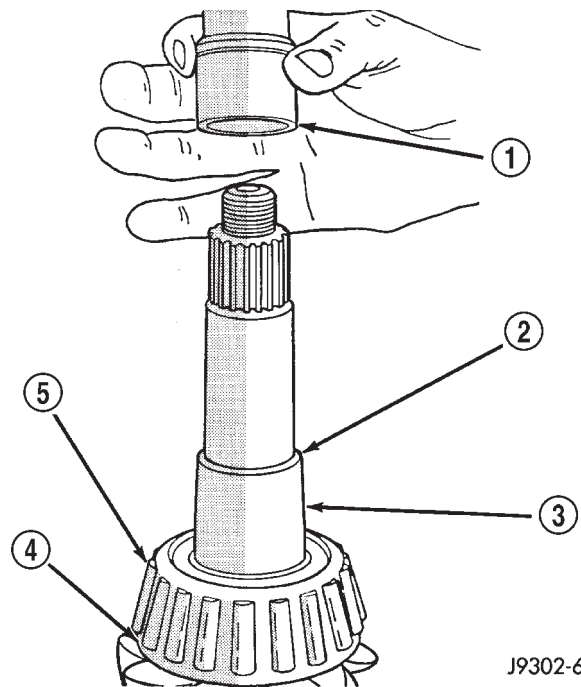
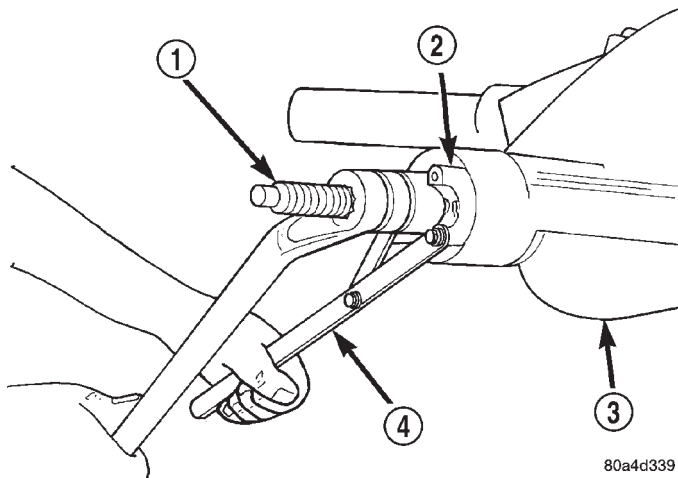

Fig. 55 Collapsible Preload Spacer

- 1 - COLLAPSIBLE SPACER
- 2 - SHOULDER
- 3 - PINION GEAR
- 4 - OIL SLINGER
- 5 - REAR BEARING

REMOVAL AND INSTALLATION (Continued)

**Fig. 56 Pinion Yoke Installation**

- 1 - SPECIAL TOOL C-3718
- 2 - PINION YOKE
- 3 - AXLE HOUSING
- 4 - SPECIAL TOOL 6958

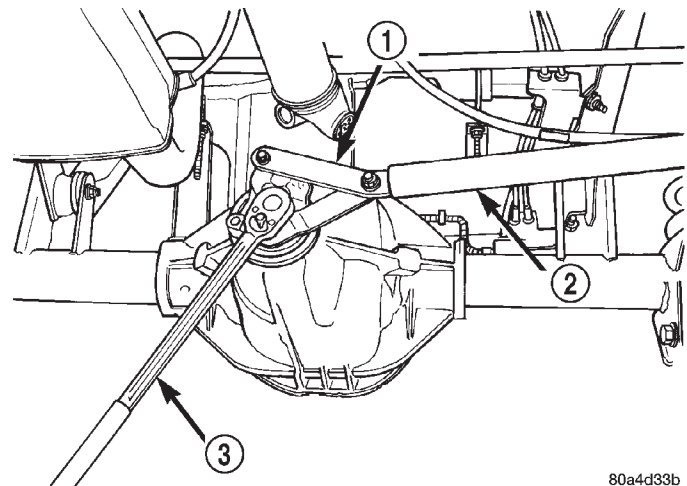
**Fig. 57 Tightening Pinion Nut**

- 1 - SPECIAL TOOL 6958
- 2 - 1 in. PIPE
- 3 - 3/4 DRIVE TORQUE WRENCH

(9) Install the yoke washer and a new nut on the pinion gear. Tighten the nut to 298 N·m (220 ft. lbs.) minimum. **Do not over-tighten.** Maximum torque is 380 N·m (280 ft. lbs.).

CAUTION: Never loosen pinion gear nut to decrease pinion gear bearing preload torque and never exceed specified preload torque. If preload torque is exceeded a new collapsible spacer must be installed. The torque sequence will have to be repeated.

NOTE: If the spacer requires more than 280 ft. lbs. torque to crush, the collapsible spacer is defective.

(10) Using yoke holder 6958, a short length of 1 in. pipe, and a torque wrench set at 380 N·m (280 ft. lbs.), crush collapsible spacer until bearing end play is taken up (Fig. 57).

(11) Slowly tighten the nut in 6.8 N·m (5 ft. lbs.) increments until the rotating torque is achieved. Measure the rotating torque frequently to avoid over crushing the collapsible spacer (Fig. 58).

(12) Rotate the pinion a minimum of ten times. Make sure that the pinion rotates smoothly. Check bearing rotating torque with an inch pound torque wrench (Fig. 58). The torque necessary to rotate the pinion gear should be:

- Original Bearings — 1 to 2 N·m (10 to 20 in. lbs.).

- New Bearings — 2.8 to 4 N·m (25 to 35 in. lbs.).

(13) Align previously made marks on yoke and propeller shaft and install propeller shaft.

(14) Install differential housing into the axle housing.

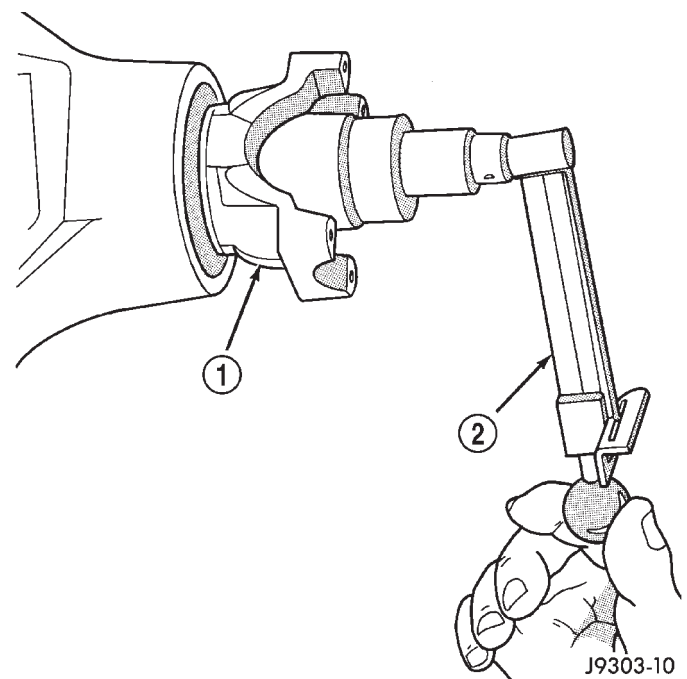
**Fig. 58 Check Pinion Gear Rotation Torque**

- 1 - PINION YOKE
- 2 - INCH POUND TORQUE WRENCH

FINAL ASSEMBLY

(1) Scrape the residual sealant from the housing and cover mating surfaces. Clean the mating surfaces with mineral spirits. Apply a bead of Mopar® Silicone Rubber Sealant, or equivalent, on the housing cover (Fig. 59).

Install the housing cover within 5 minutes after applying the sealant.

REMOVAL AND INSTALLATION (Continued)

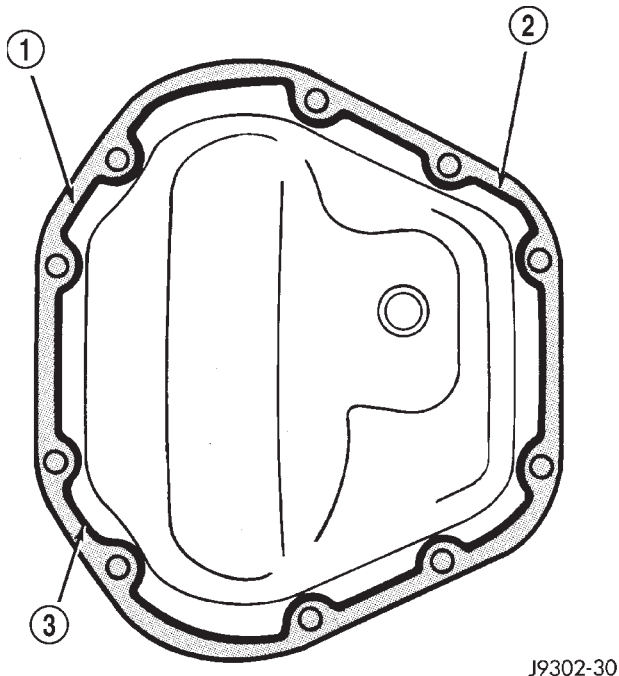

J9302-30

Fig. 59 Typical Housing Cover With Sealant

- 1 - SEALING SURFACE
- 2 - CONTOUR OF BEAD
- 3 - BEAD THICKNESS 6.35MM (1/4")

(2) Install the cover on the differential with the attaching bolts. Install the identification tag. Tighten the cover bolts to 41 N·m (30 ft. lbs.) torque.

CAUTION: Overfilling the differential can result in lubricant foaming and overheating.

(3) Refill the differential housing with gear lubricant. Refer to the Lubricant Specifications section of this group for the gear lubricant requirements.

(4) Install the fill hole plug.

DISASSEMBLY AND ASSEMBLY

STANDARD DIFFERENTIAL

DISASSEMBLY

- (1) Remove pinion mate shaft lock screw (Fig. 60).
- (2) Remove pinion mate shaft.
- (3) Rotate the differential side gears and remove the differential pinion gears and thrust washers (Fig. 61).
- (4) Remove the differential side gears and thrust washers.

ASSEMBLY

- (1) Install the differential side gears and thrust washers.

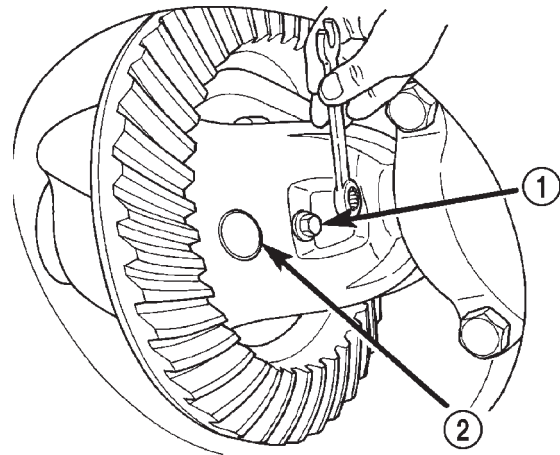

80be4604

Fig. 60 Pinion Mate Shaft Lock Screw

- 1 - LOCK SCREW
- 2 - PINION MATE SHAFT

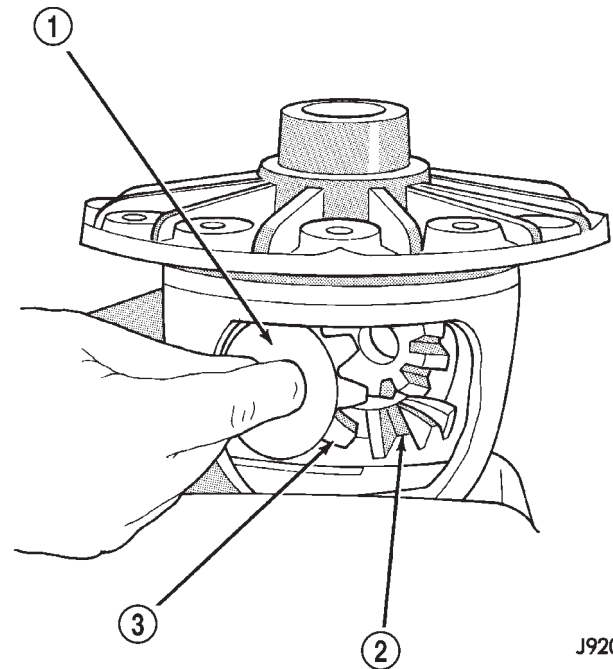

J9203-61

Fig. 61 Pinion Mate Gear Removal

- 1 - THRUST WASHER
- 2 - SIDE GEAR
- 3 - PINION MATE GEAR

(2) Install the differential pinion gears and thrust washers.

(3) Install the pinion mate shaft.

(4) Align the hole in the pinion mate shaft with the hole in the differential case and install the pinion mate shaft lock screw.

(5) Lubricate all differential components with hypoid gear lubricant.

DISASSEMBLY AND ASSEMBLY (Continued)

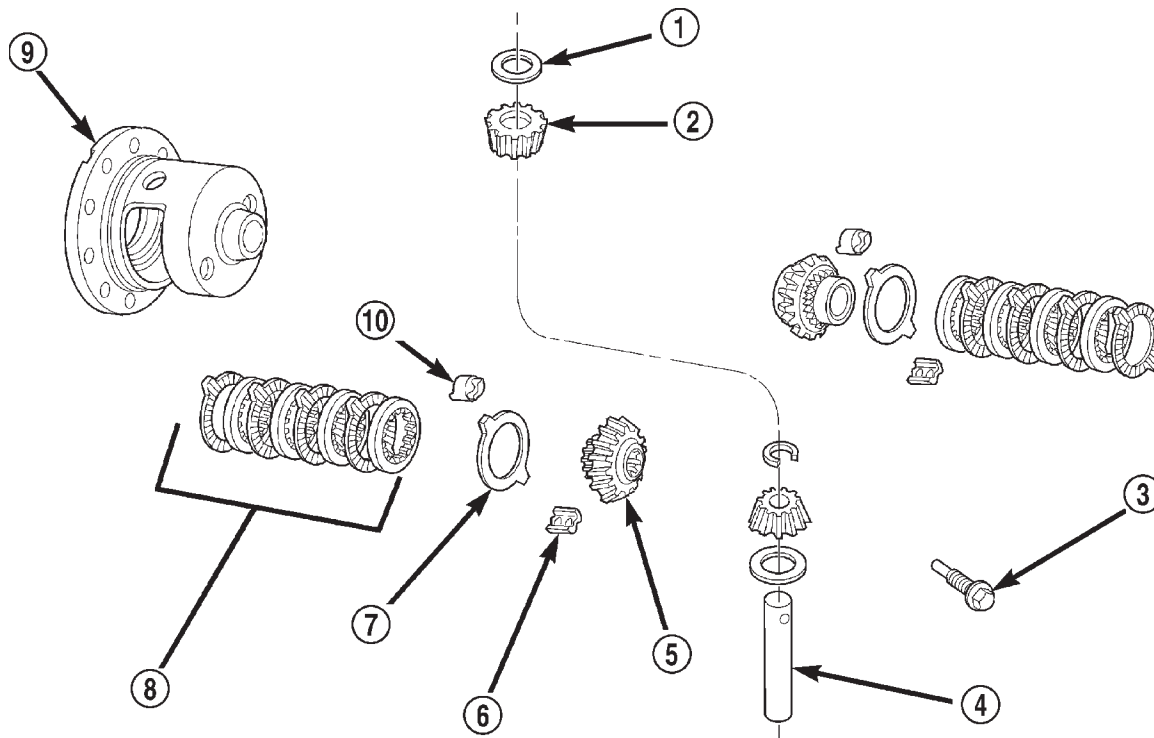

80a77404

Fig. 62 Trac-Lok™ Differential Components

- | | |
|-----------------------|-----------------------|
| 1 - THRUST WASHER | 6 - RETAINER |
| 2 - PINION | 7 - DISC |
| 3 - SHAFT LOCK SCREW | 8 - CLUTCH PACK |
| 4 - PINION MATE SHAFT | 9 - DIFFERENTIAL CASE |
| 5 - SIDE GEAR | 10 - RETAINER |

TRAC-LOK™ DIFFERENTIAL

The Trac-Lok™ differential components are illustrated in (Fig. 62). Refer to this illustration during repair service.

DISASSEMBLY

(1) Clamp Side Gear Holding Tool 6963-A in a vise.

(2) Position the differential case on Side Gear Holding Tool 6963-A (Fig. 63).

(3) Remove ring gear, if necessary. Ring gear removal is necessary only if the ring gear is to be replaced. The Trac-Lok™ differential can be serviced with the ring gear installed.

(4) Remove the pinion gear mate shaft lock screw (Fig. 64).

(5) Remove the pinion gear mate shaft. If necessary, use a drift and hammer (Fig. 65).

(6) Install and lubricate Step Plate C-4487-1 (Fig. 66).

DISASSEMBLY AND ASSEMBLY (Continued)

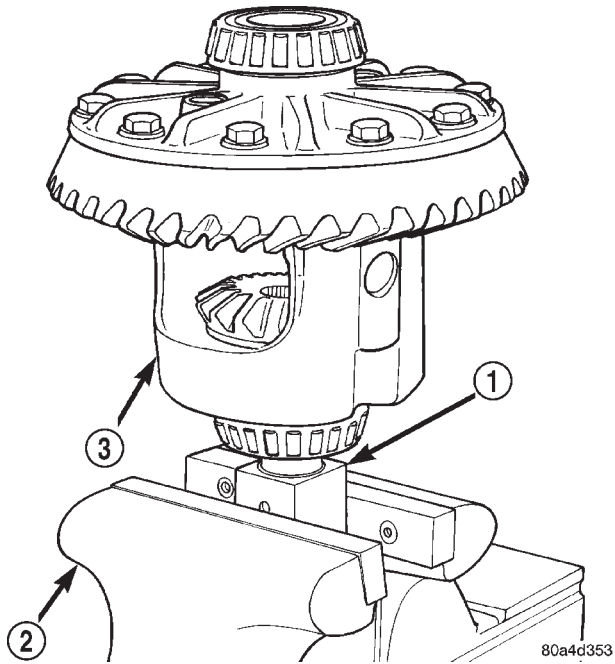
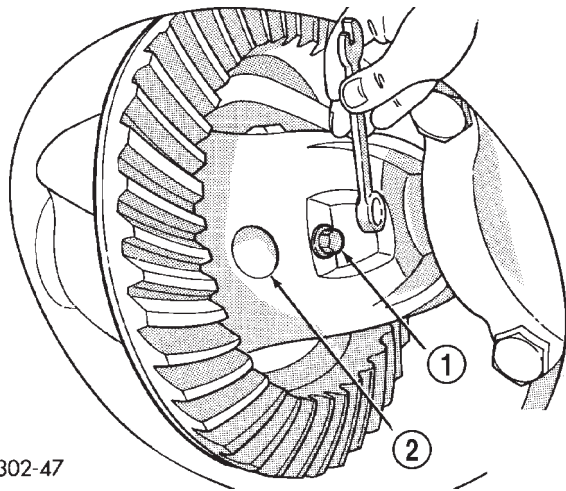

Fig. 63 Differential Case Holding Tool

- 1 - SPECIAL TOOL 6963-A
- 2 - VISE
- 3 - TRAC-LOK DIFFERENTIAL



J9302-47

Fig. 64 Mate Shaft Lock Screw

- 1 - LOCK SCREW
- 2 - PINION GEAR MATE SHAFT

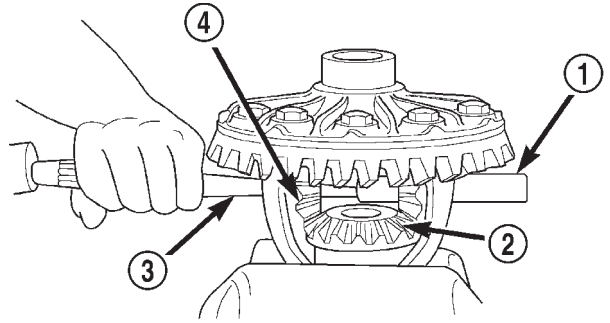

80a773e1

Fig. 65 Mate Shaft Removal

- 1 - PINION MATE SHAFT
- 2 - SIDE GEAR
- 3 - DRIFT
- 4 - PINION MATE GEAR

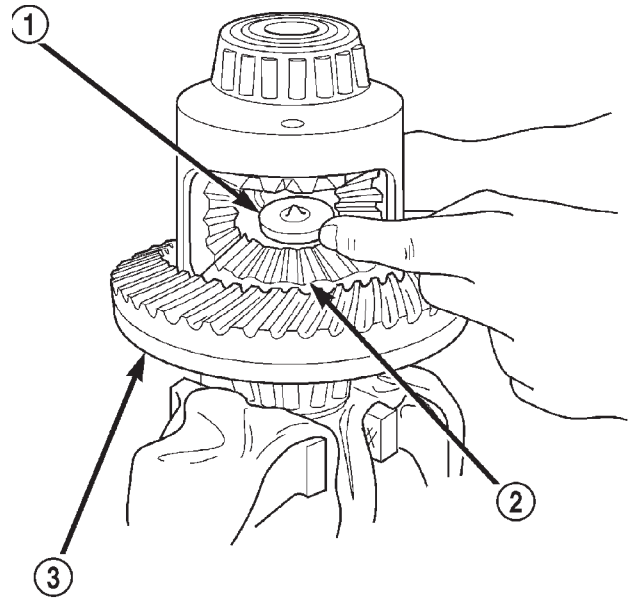

80a773df

Fig. 66 Step Plate Tool Installation

- 1 - SPECIAL TOOL C-4487-1
- 2 - LOWER SIDE GEAR
- 3 - DIFFERENTIAL CASE

DISASSEMBLY AND ASSEMBLY (Continued)

(7) Assemble Threaded Adapter C-4487-3 into top side gear. Thread Forcing Screw C-4487-2 into adapter until it becomes centered in adapter plate.

(8) Position a small screw driver in slot of Threaded Adapter C-4487-3 (Fig. 67) to prevent adapter from turning.

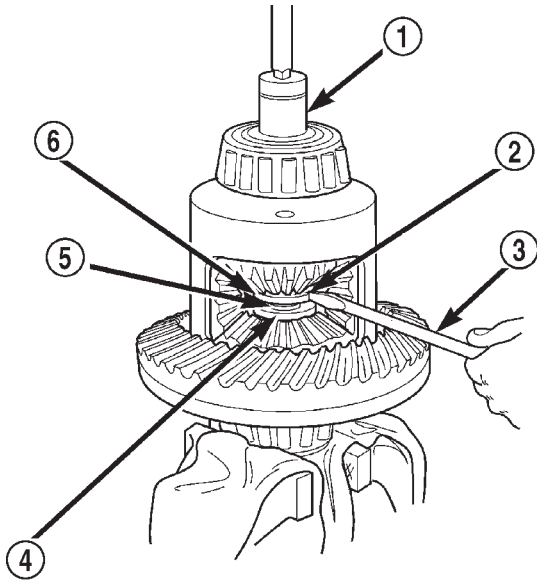

80a773de

Fig. 67 Threaded Adapter Installation

- 1 - SOCKET
- 2 - SLOT IN ADAPTER
- 3 - SCREWDRIVER
- 4 - DISC C-4487-1
- 5 - THREADED ROD C-4487-2
- 6 - THREADED ADAPTER DISC C-4487-3

(9) Tighten forcing screw tool 122 N·m (90 ft. lbs.) (maximum) to compress Belleville springs in clutch packs (Fig. 68).

(10) Using an appropriate size feeler gauge, remove thrust washers from behind the pinion gears (Fig. 69).

(11) Insert Turning Bar C-4487-4 in case (Fig. 70).

(12) Loosen the Forcing Screw C-4487-2 in small increments until the clutch pack tension is relieved and the differential case can be turned using Turning Bar C-4487-4.

(13) Rotate differential case until the pinion gears can be removed.

(14) Remove pinion gears from differential case.

(15) Remove Forcing Screw C-4487-2, Step Plate C-4487-1, and Threaded Adapter C-4487-3.

(16) Remove top side gear, clutch pack retainer, and clutch pack. Keep plates in correct order during removal (Fig. 71).

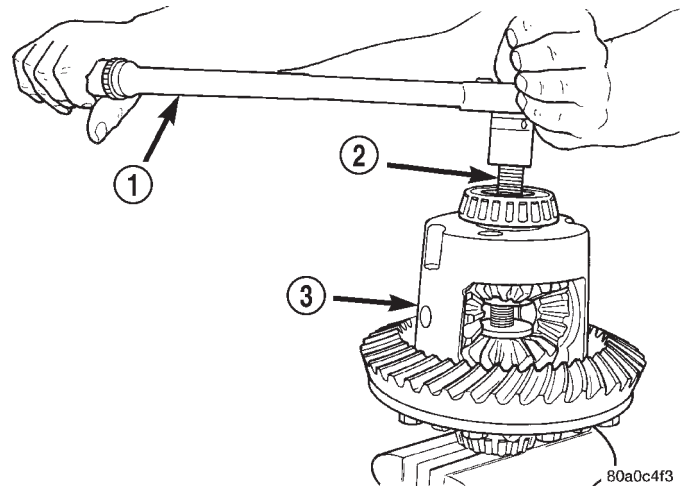

80a0c4f3

Fig. 68 Tighten Belleville Spring Compressor Tool

- 1 - TORQUE WRENCH
- 2 - TOOL ASSEMBLED
- 3 - DIFFERENTIAL CASE

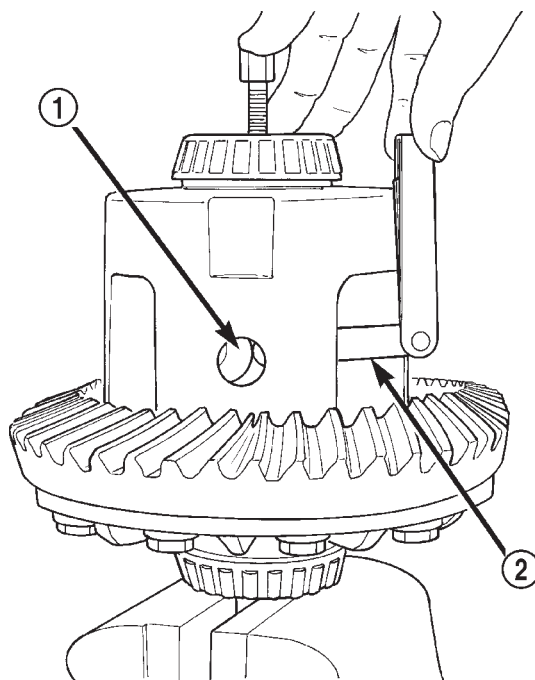

80a77406

Fig. 69 Remove Pinion Gear Thrust Washer

- 1 - THRUST WASHER
- 2 - FEELER GAUGE

(17) Remove differential case from Side Gear Holding Tool 6963-A. Remove side gear, clutch pack retainer, and clutch pack. Keep plates in correct order during removal.

DISASSEMBLY AND ASSEMBLY (Continued)

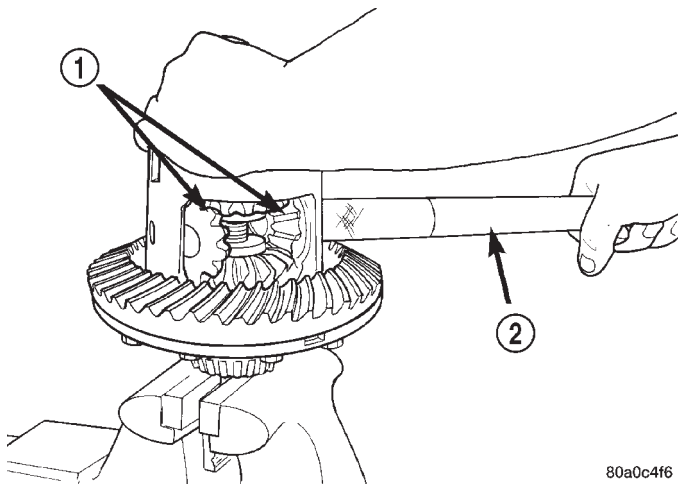

80a0c4f6

Fig. 70 Pinion Gear Removal

- 1 - PINION GEARS
- 2 - TOOL

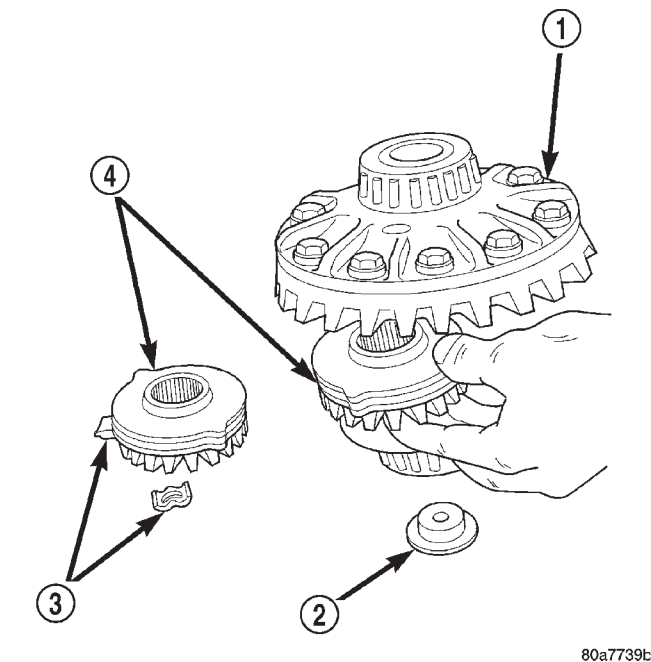

80a7739b

Fig. 71 Side Gear & Clutch Disc Removal

- 1 - DIFFERENTIAL CASE
- 2 - SPECIAL TOOL C-4487-1
- 3 - RETAINER
- 4 - SIDE GEAR AND CLUTCH DISC PACK

ASSEMBLY

NOTE: The clutch discs are replaceable as complete sets only. If one clutch disc pack is damaged, both packs must be replaced.

Lubricate each component with gear lubricant before assembly.

(1) Assemble the clutch discs into packs and secure disc packs with retaining clips (Fig. 72).

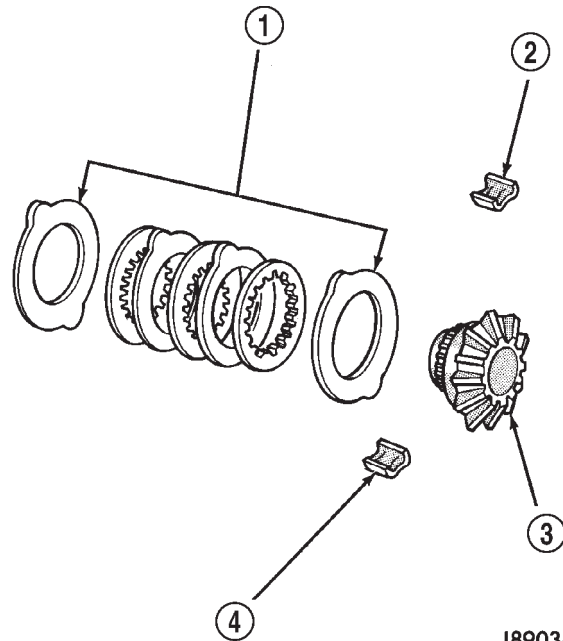

J8903-50

Fig. 72 Clutch Disc Pack

- 1 - CLUTCH PACK
- 2 - RETAINER
- 3 - SIDE GEAR
- 4 - RETAINER

(2) Position assembled clutch disc packs on the side gear hubs.

(3) Install clutch pack and side gear in the ring gear side of the differential case (Fig. 73). **Be sure clutch pack retaining clips remain in position and are seated in the case pockets.**

(4) Position the differential case on Side Gear Holding Tool 6963-A.

(5) Install lubricated Step Plate C-4487-1 on side gear (Fig. 74).

(6) Install the upper side gear and clutch disc pack (Fig. 74).

(7) Hold assembly in position. Insert Threaded Adapter C-4487-3 into top side gear.

(8) Insert Forcing Screw C-4487-2.

(9) Tighten forcing screw tool to slightly compress clutch discs.

(10) Place pinion gears in position in side gears and verify that the pinion mate shaft hole is aligned.

(11) Rotate case with Turning Bar C-4487-4 until the pinion mate shaft holes in pinion gears align with holes in case. It may be necessary to slightly tighten the forcing screw in order to install the pinion gears.

(12) Tighten forcing screw to 122 N·m (90 ft. lbs.) to compress the Belleville springs.

DISASSEMBLY AND ASSEMBLY (Continued)

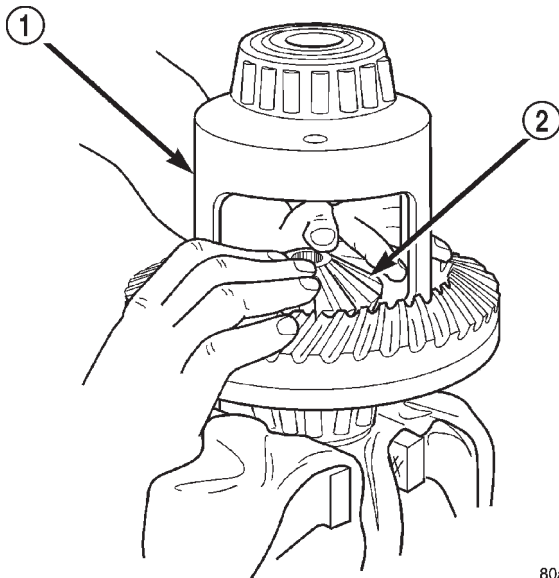

80a7739c

Fig. 73 Clutch Discs & Lower Side Gear Installation

- 1 - DIFFERENTIAL CASE
2 - LOWER SIDE GEAR AND CLUTCH DISC PACK

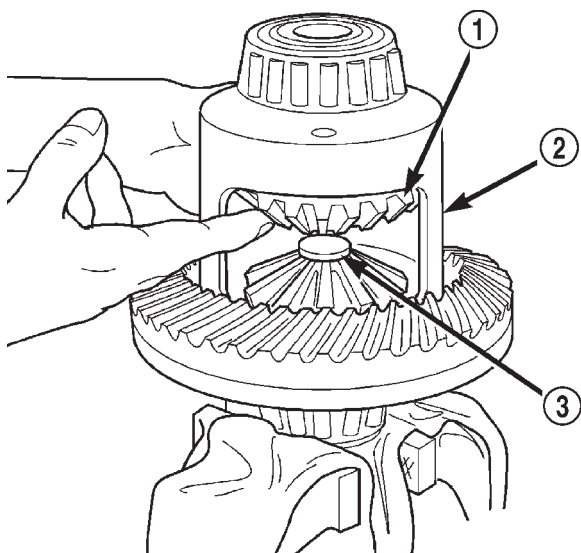

80a773e0

Fig. 74 Upper Side Gear & Clutch Disc Pack Installation

- 1 - UPPER SIDE GEAR AND CLUTCH DISC PACK
2 - DIFFERENTIAL CASE
3 - SPECIAL TOOL C-4487-1

(13) Lubricate and install thrust washers behind pinion gears and align washers with a small screw driver. Insert mate shaft into each pinion gear to verify alignment.

(14) Remove forcing screw, threaded adapter, and step plate.

(15) Install pinion gear mate shaft and align holes in shaft and case.

(16) Install the pinion mate shaft lock screw finger tight to hold shaft during differential installation.

If replacement side and/or pinion gears and thrust washers were installed, it is not necessary to measure the side gear backlash. Correct fit is due to close machining tolerances during manufacture.

(17) Lubricate all differential components with hypoid gear lubricant.

CLEANING AND INSPECTION

AXLE COMPONENTS

Wash differential components with cleaning solvent and dry with compressed air. **Do not steam clean the differential components.**

Wash bearings with solvent and towel dry, or dry with compressed air. **DO NOT** spin bearings with compressed air. **Cup and bearing must be replaced as matched sets only.**

Clean axle shaft tubes and oil channels in housing. Inspect for;

- Smooth appearance with no broken/dented surfaces on the bearing rollers or the roller contact surfaces.
- Bearing cups must not be distorted or cracked.
- Machined surfaces should be smooth and without any raised edges.
- Raised metal on shoulders of cup bores should be removed with a hand stone.
- Wear and damage to pinion gear mate shaft, pinion gears, side gears and thrust washers. Replace as a matched set only.
- Ring and pinion gear for worn and chipped teeth.
- Ring gear for damaged bolt threads. Replaced as a matched set only.
- Pinion yoke for cracks, worn splines, pitted areas, and a rough/corroded seal contact surface. Repair or replace as necessary.
- Preload shims for damage and distortion. Install new shims, if necessary.

TRAC-LOK™

Clean all components in cleaning solvent. Dry components with compressed air. Inspect clutch pack plates for wear, scoring or damage. Replace both clutch packs if any one component in either pack is damaged. Inspect side gears and pinions. Replace any gear that is worn, cracked, chipped or damaged. Inspect differential case and pinion shaft. Replace if worn or damaged.

CLEANING AND INSPECTION (Continued)

PRESOAK PLATES AND DISC

Plates and discs with fiber coating (no grooves or lines) must be presoaked in Friction Modifier before assembly. Soak plates and discs for a minimum of 20 minutes.

ADJUSTMENTS

PINION GEAR DEPTH

GENERAL INFORMATION

Ring and pinion gears are supplied as matched sets only. The identifying numbers for the ring and pinion gear are etched into the face of each gear (Fig. 75). A plus (+) number, minus (-) number or zero (0) is etched into the face of the pinion gear. This number is the amount (in thousandths of an inch) the depth varies from the standard depth setting of a pinion etched with a (0). The standard setting from the center line of the ring gear to the back face of the pinion is 109.52 mm (4.312 in.). The standard depth provides the best teeth contact pattern. Refer to Backlash and Contact Pattern Analysis Paragraph in this section for additional information.

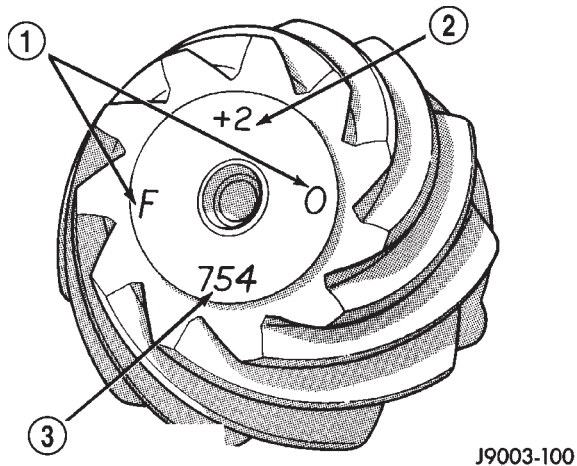
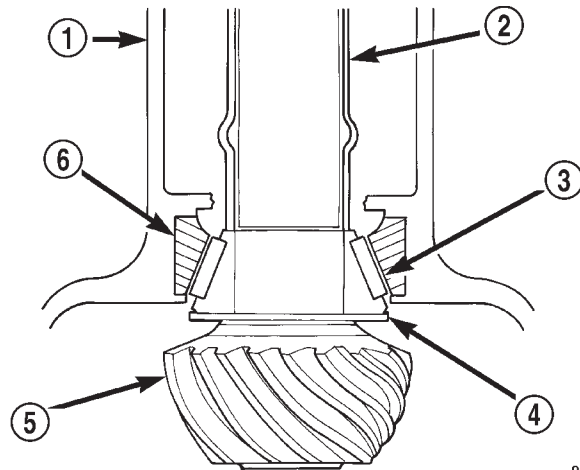

Fig. 75 Pinion Gear ID Numbers

- 1 - PRODUCTION NUMBERS
- 2 - DRIVE PINION GEAR DEPTH VARIANCE
- 3 - GEAR MATCHING NUMBER (SAME AS RING GEAR NUMBER)

Compensation for pinion depth variance is achieved with select shims. The shims are placed under the inner pinion bearing cone (Fig. 76).

If a new gear set is being installed, note the depth variance etched into both the original and replacement pinion gear. Add or subtract the thickness of the original depth shims to compensate for the difference in the depth variances. Refer to the Depth Variance charts.



80a0c4f8

Fig. 76 Shim Locations

- 1 - AXLE HOUSING
- 2 - COLLAPSIBLE SPACER
- 3 - PINION BEARING
- 4 - PINION DEPTH SHIM
- 5 - PINION GEAR
- 6 - BEARING CUP

Note where Old and New Pinion Marking columns intersect. Intersecting figure represents plus or minus amount needed.

Note the etched number on the face of the drive pinion gear (-1, -2, 0, +1, +2, etc.). The numbers represent thousands of an inch deviation from the standard. If the number is negative, add that value to the required thickness of the depth shim(s). If the number is positive, subtract that value from the thickness of the depth shim(s). If the number is 0, no change is necessary. Refer to the Pinion Gear Depth Variance Chart.

PINION DEPTH MEASUREMENT AND ADJUSTMENT

Measurements are taken with pinion cups and pinion bearings installed in housing. Take measurements with Pinion Gauge Set 6955, Dummy Bearing/Arbor Disc Set 6956, and Dial Indicator C-3339 (Fig. 77).

(1) Assemble Pinion Height Block 6739, Pinion Block 8144, and rear pinion bearing onto Screw 6741 (Fig. 77).

(2) Insert assembled height gauge components, rear bearing and screw into axle housing through pinion bearing cups (Fig. 78).

(3) Install front pinion bearing and Cone 6740 hand tight (Fig. 77).

(4) Place Arbor Discs 6927A on Arbor D-115-3 in position in axle housing side bearing cradles (Fig. 79). Install differential bearing caps on Arbor Discs and tighten cap bolts. Refer to the Torque Specifications in this section.

ADJUSTMENTS (Continued)

PINION GEAR DEPTH VARIANCE

Original Pinion Gear Depth Variance	Replacement Pinion Gear Depth Variance								
	-4	-3	-2	-1	0	+1	+2	+3	+4
+4	+0.008	+0.007	+0.006	+0.005	+0.004	+0.003	+0.002	+0.001	0
+3	+0.007	+0.006	+0.005	+0.004	+0.003	+0.002	+0.001	0	-0.001
+2	+0.006	+0.005	+0.004	+0.003	+0.002	+0.001	0	-0.001	-0.002
+1	+0.005	+0.004	+0.003	+0.002	+0.001	0	-0.001	-0.002	-0.003
0	+0.004	+0.003	+0.002	+0.001	0	-0.001	-0.002	-0.003	-0.004
-1	+0.003	+0.002	+0.001	0	-0.001	-0.002	-0.003	-0.004	-0.005
-2	+0.002	+0.001	0	-0.001	-0.002	-0.003	-0.004	-0.005	-0.006
-3	+0.001	0	-0.001	-0.002	-0.003	-0.004	-0.005	-0.006	-0.007
-4	0	-0.001	-0.002	-0.003	-0.004	-0.005	-0.006	-0.007	-0.008

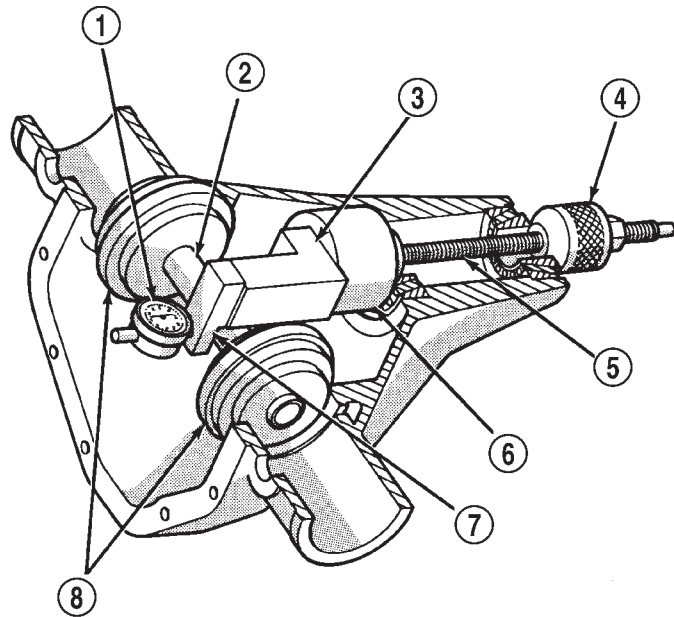

J9403-45

Fig. 77 Pinion Gear Depth Gauge Tools—Typical

- 1 - DIAL INDICATOR
- 2 - ARBOR
- 3 - PINION HEIGHT BLOCK
- 4 - CONE
- 5 - SCREW
- 6 - PINION BLOCK
- 7 - SCOOTER BLOCK
- 8 - ARBOR DISC

NOTE: Arbor Discs 6927A have different step diameters to fit other axle sizes. Pick correct size step for axle being serviced.

(5) Assemble Dial Indicator C-3339 into Scooter Block D-115-2 and secure set screw.

(6) Place Scooter Block/Dial Indicator in position in axle housing so dial probe and scooter block are

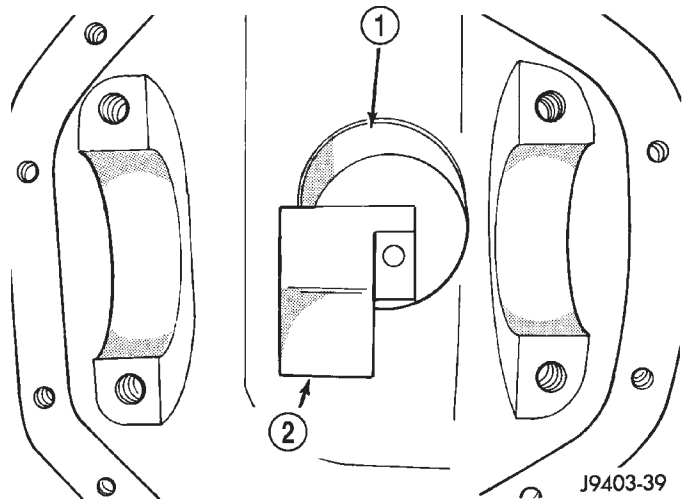

Fig. 78 Pinion Height Block—Typical

- 1 - PINION BLOCK
- 2 - PINION HEIGHT BLOCK

flush against the surface of the pinion height block. Hold scooter block in place and zero the dial indicator face to the pointer. Tighten dial indicator face lock screw.

(7) With scooter block still in position against the pinion height block, slowly slide the dial indicator probe over the edge of the pinion height block. Observe how many revolutions counterclockwise the dial pointer travels (approximately 0.125 in.) to the out-stop of the dial indicator.

(8) Slide the dial indicator probe across the gap between the pinion height block and the arbor bar with the scooter block against the pinion height block (Fig. 80). When the dial probe contacts the arbor bar, the dial pointer will turn clockwise. Bring dial pointer back to zero against the arbor bar, do not turn dial face. Continue moving the dial probe to the crest of the arbor bar and record the highest reading.

ADJUSTMENTS (Continued)

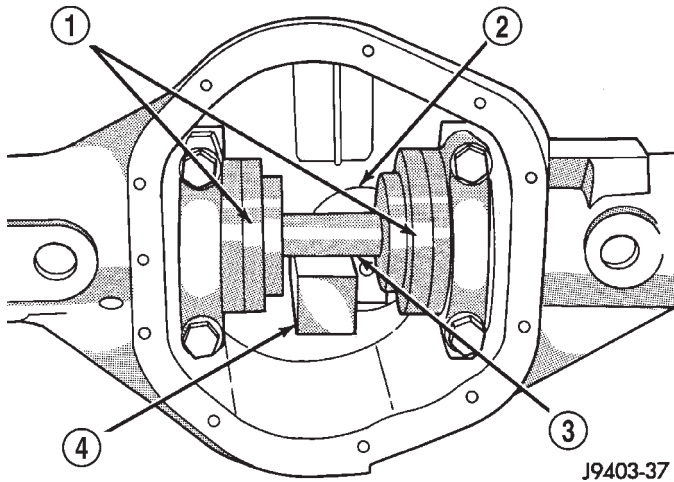

J9403-37

Fig. 79 Gauge Tools In Housing—Typical

- 1 - ARBOR DISC
- 2 - PINION BLOCK
- 3 - ARBOR
- 4 - PINION HEIGHT BLOCK

If the dial indicator can not achieve the zero reading, the rear bearing cup or the pinion depth gauge set is not installed correctly.

(9) Select a shim equal to the dial indicator reading plus the drive pinion gear depth variance number etched in the face of the pinion gear (Fig. 75) using the opposite sign on the variance number. For example, if the depth variance is -2, add +0.002 in. to the dial indicator reading.

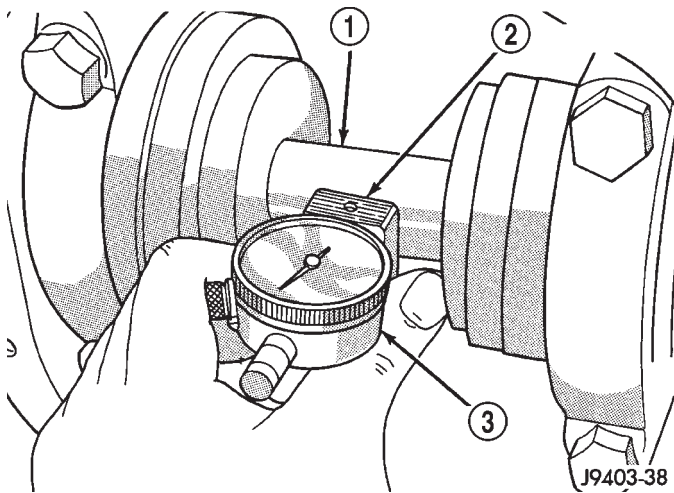

J9403-38

Fig. 80 Pinion Gear Depth Measurement—Typical

- 1 - ARBOR
- 2 - SCOOTER BLOCK
- 3 - DIAL INDICATOR

(10) Remove the pinion depth gauge components from the axle housing

DIFFERENTIAL BEARING PRELOAD AND GEAR BACKLASH

Differential side bearing preload and gear backlash is achieved by selective shims inserted between the bearing cup and the axle housing. The proper shim thickness can be determined using slip-fit dummy bearings 6929-A in place of the differential side bearings and a dial indicator C-3339. Before proceeding with the differential bearing preload and gear backlash measurements, measure the pinion gear depth and prepare the pinion gear for installation. Establishing proper pinion gear depth is essential to establishing gear backlash and tooth contact patterns. After the overall shim thickness to take up differential side play is measured, the pinion gear is installed, and the gear backlash shim thickness is measured. The overall shim thickness is the total of the dial indicator reading, starting point shim thickness, and the preload specification added together. The gear backlash measurement determines the thickness of the shim used on the ring gear side of the differential case. Subtract the gear backlash shim thickness from the total overall shim thickness and select that amount for the pinion gear side of the differential (Fig. 81).

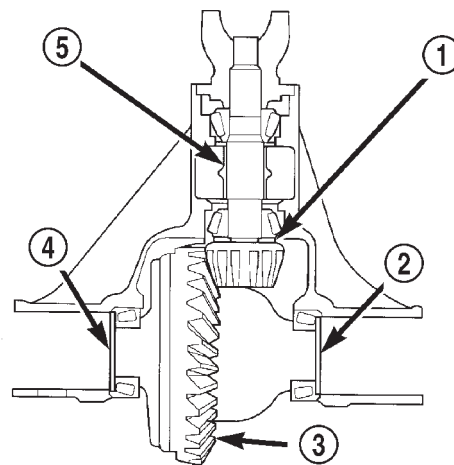

80a5037a

Fig. 81 Axle Adjustment Shim Locations

- 1 - PINION GEAR DEPTH SHIM
- 2 - DIFFERENTIAL BEARING SHIM-PINION GEAR SIDE
- 3 - RING GEAR
- 4 - DIFFERENTIAL BEARING SHIM-RING GEAR SIDE
- 5 - COLLAPSIBLE SPACER

ADJUSTMENTS (Continued)

DIFFERENTIAL PRELOAD AND GEAR BACKLASH SHIM SELECTION

NOTE: It is difficult to salvage the differential side bearings during the removal procedure. Install replacement bearings if necessary.

- (1) Remove side bearings from differential case.
- (2) Install ring gear on differential case and tighten bolts to specification.
- (3) Install dummy side bearings 6929-A on differential case.
- (4) Install differential case in axle housing.
- (5) Measure and record the thickness of Dummy Shims 8107 (0.118 in. (3.0 mm)) starting point shims for future reference. Insert Dummy Shims 8107 between the dummy bearing and the axle housing on side of differential (Fig. 82).

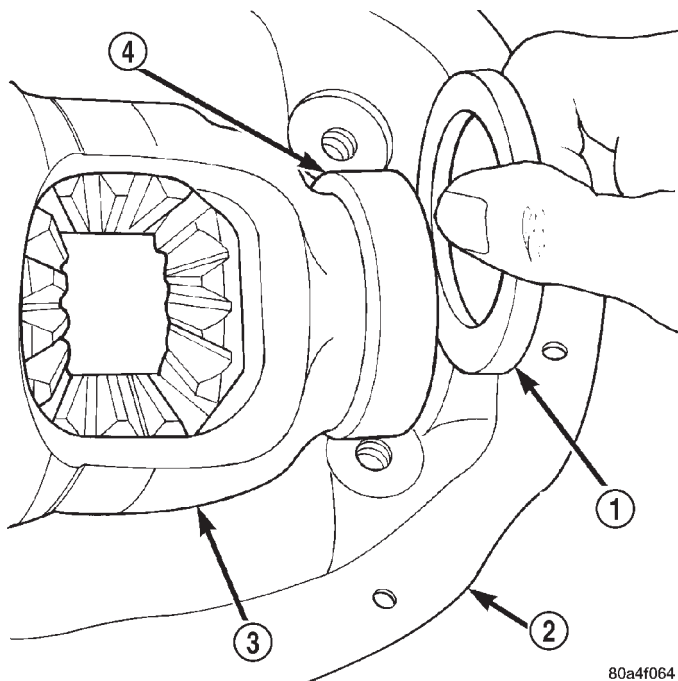

80a4f064

Fig. 82 Preload Measurement Starting Point Shim

- 1 - STARTING POINT SHIM
- 2 - AXLE HOUSING
- 3 - DIFFERENTIAL CASE
- 4 - SPECIAL TOOL 6929-A

(6) Install the marked bearing caps in their correct positions. Install and snug the bolts.

(7) Using a dead-blow type mallet, seat the differential dummy bearings to each side of the axle housing (Fig. 83) and (Fig. 84).

(8) Thread guide stud C-3288-B into rear cover bolt hole below ring gear (Fig. 85).

(9) Attach dial indicator C-3339 to Guide Stud C-3288-B. Position the dial indicator plunger on a

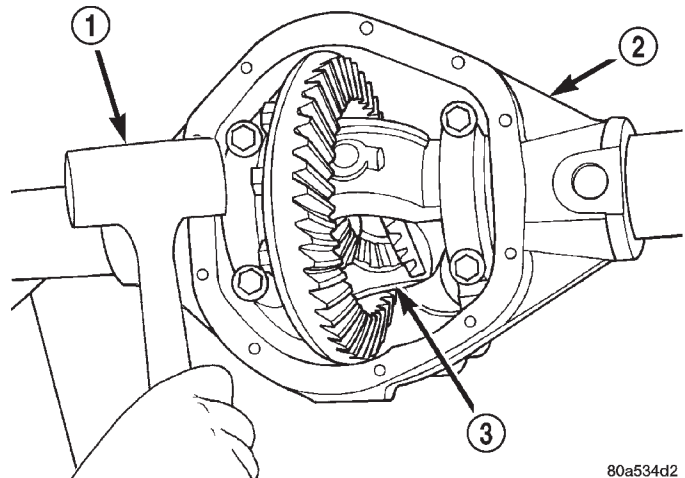

80a534d2

Fig. 83 Seat Pinion Gear Side Dummy Bearing

- 1 - MALLET
- 2 - AXLE HOUSING
- 3 - DIFFERENTIAL CASE

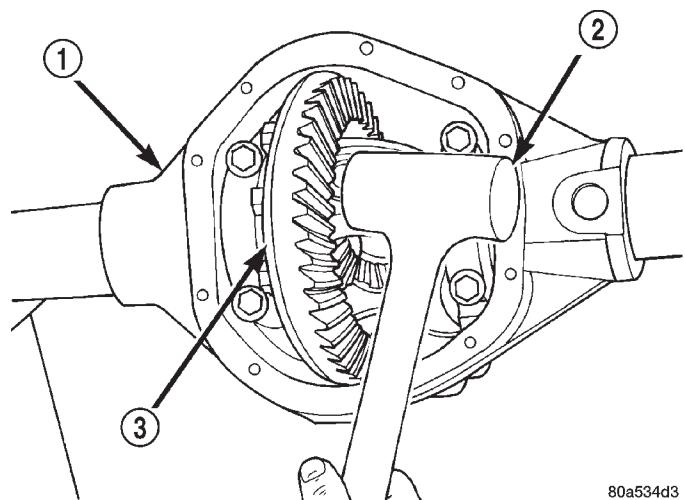

80a534d3

Fig. 84 Seat Ring Gear Side Dummy Bearing

- 1 - AXLE HOUSING
- 2 - MALLET
- 3 - DIFFERENTIAL CASE

flat surface between the ring gear bolt heads (Fig. 85).

(10) Push and hold differential case to pinion gear side of axle housing.

(11) Zero dial indicator face to pointer (Fig. 86).

(12) Push and hold differential case to ring gear side of the axle housing.

(13) Record dial indicator reading (Fig. 87).

(14) Add the dial indicator reading to the starting point shim thickness to determine total shim thickness to achieve zero differential end play.

(15) Add 0.001 in. (0.0254 mm) to the zero end play total. This new total represents the thickness of

ADJUSTMENTS (Continued)

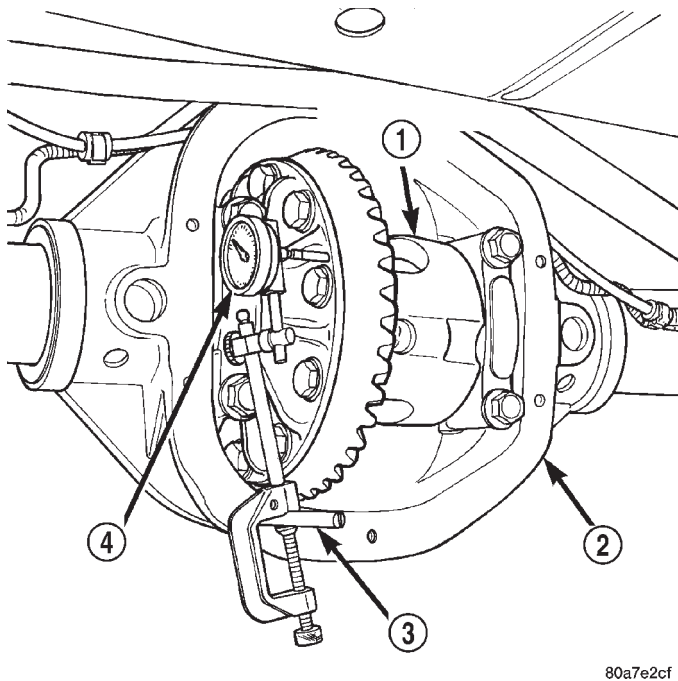
**Fig. 85 Differential Side play Measurement**

- 1 - DIFFERENTIAL CASE
- 2 - AXLE HOUSING
- 3 - SPECIAL TOOL C-3288-B
- 4 - SPECIAL TOOL C-3339

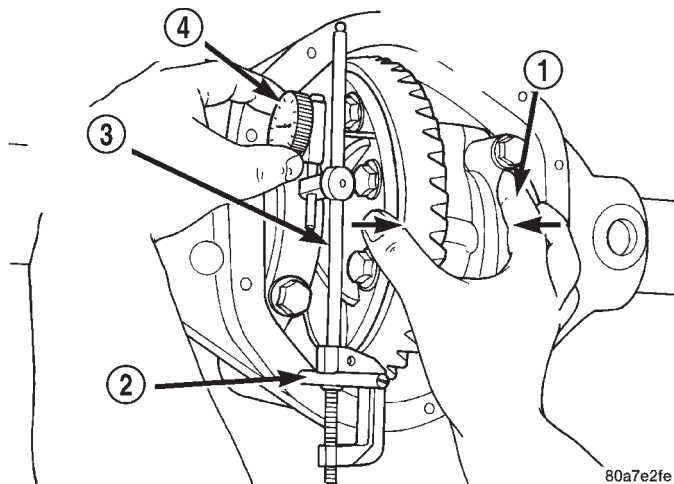
**Fig. 86 Hold Differential Case and Zero Dial Indicator**

- 1 - FORCE DIFFERENTIAL CASE TO PINION GEAR SIDE
- 2 - SPECIAL TOOL C-3288-B
- 3 - SPECIAL TOOL C-3339
- 4 - ZERO DIAL INDICATOR FACE

shims to compress, or preload the new bearings when the differential is installed.

(16) Rotate dial indicator out of the way on guide stud.

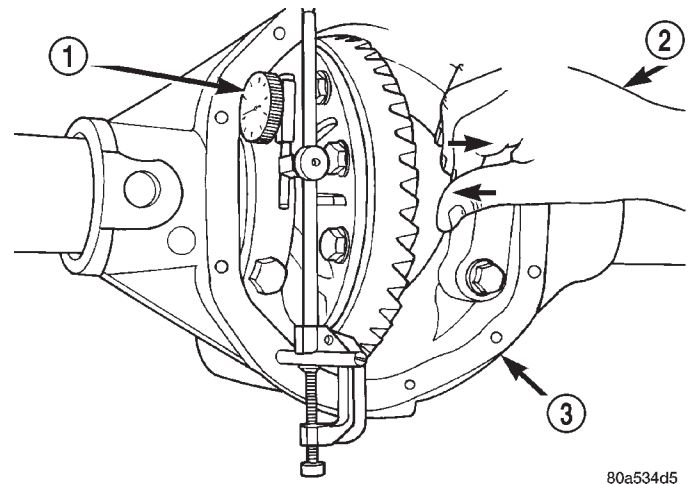
**Fig. 87 Hold Differential Case and Read Dial Indicator**

- 1 - READ DIAL INDICATOR
- 2 - FORCE DIFFERENTIAL CASE TO RING GEAR SIDE
- 3 - AXLE HOUSING

(17) Remove differential case, dummy bearings, and starting point shims from axle housing.

(18) Install pinion gear in axle housing. Install the yoke and establish the correct pinion rotating torque. Record the value of the pinion rotating torque for use in establishing the differential total torque to rotate.

(19) Install differential case and dummy bearings in axle housing with a single Dummy Shim 8107 installed between the ring gear side dummy bearing and the axle housing. Install the bearing caps and tighten the cap bolts snug.

(20) Position the dial indicator plunger on a flat surface between the ring gear bolt heads (Fig. 85).

(21) Push and hold differential case toward pinion gear.

(22) Zero dial indicator face to pointer.

(23) Push and hold differential case to ring gear side of the axle housing.

(24) Record dial indicator reading. Add the starting point shim thickness to the dial indicator reading to obtain the total shim thickness necessary to achieve zero backlash.

(25) Subtract 0.006 in. (0.152 mm) from the recorded value to compensate for backlash between ring and pinion gears. This total is the thickness of shim required to achieve proper backlash.

(26) Subtract the backlash shim thickness from the total preload shim thickness. The remainder is the shim thickness required on the pinion side of the axle housing.

(27) Rotate dial indicator out of the way on guide stud.

(28) Remove differential case, dummy shim, and dummy bearings from axle housing.

ADJUSTMENTS (Continued)

(29) Install new side bearing cones and cups on differential case.

(30) Install spreader W-129-B on axle housing and spread axle opening enough to receive differential case and side bearing shims.

(31) Place side bearing shims in axle housing against axle tube ends.

(32) Install differential case in axle housing.

(33) Remove spreader from axle housing.

(34) Rotate the differential case several times to seat the side bearings.

(35) Position the indicator plunger against a ring gear tooth (Fig. 88).

(36) Push and hold ring gear upward while not allowing the pinion gear to rotate.

(37) Zero dial indicator face to pointer.

(38) Push and hold ring gear downward while not allowing the pinion gear to rotate. Dial indicator reading should be between 0.12 mm (0.005 in.) and 0.20 mm (0.008 in.). If backlash is not within specifications transfer the necessary amount of shim thickness from one side of the axle housing to the other (Fig. 89).

(39) Verify differential case and ring gear runout by measuring ring to pinion gear backlash at eight locations around the ring gear. Readings should not vary more than 0.05 mm (0.002 in.). If readings vary more than specified, the ring gear or the differential case is defective.

After the proper backlash is achieved, perform the Gear Contact Pattern Analysis procedure. Adjust as necessary.

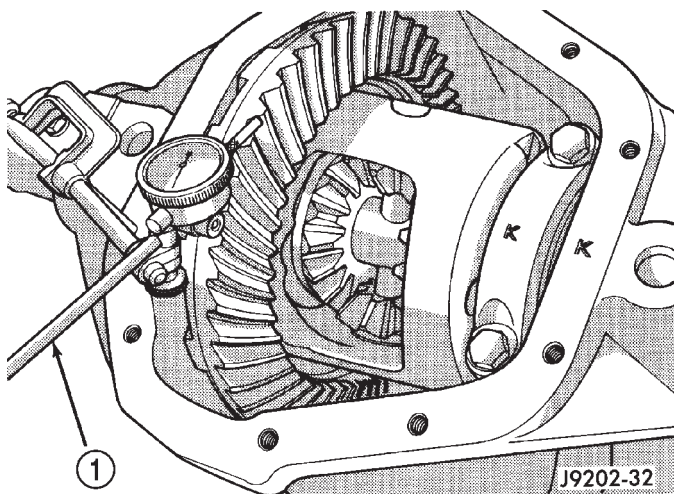

Fig. 88 Ring Gear Backlash Measurement

1 - DIAL INDICATOR

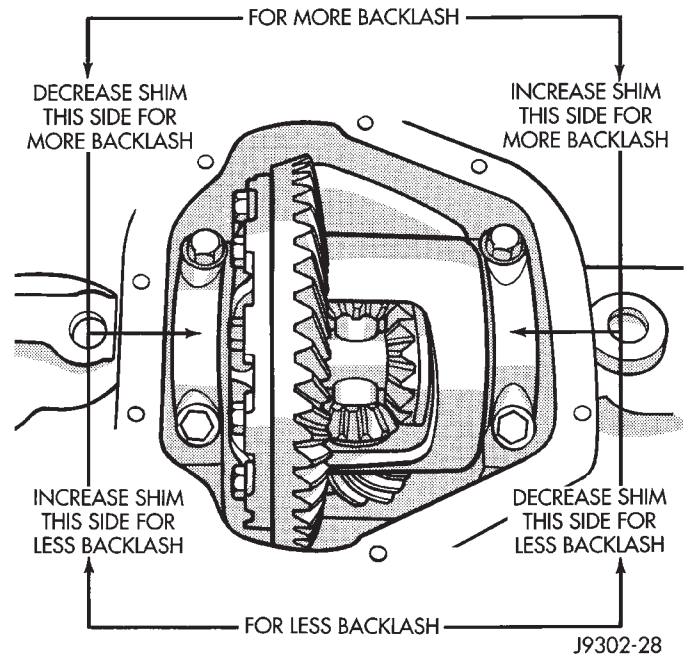

Fig. 89 Backlash Shim Adjustment

DIFFERENTIAL TOTAL TORQUE TO ROTATE

(1) Rotate the pinion a minimum of ten times to seat the differential bearings. Verify that the rotation is smooth and repeatable.

(2) While rotating the pinion at a slow steady rate, measure the differential total torque to rotate. Record the value.

(3) The differential total torque to rotate must be greater than the pinion torque to rotate plus 5 in.lbs. for axles equipped with a standard differential. On axles equipped with a Vari-Lok™ differential, the differential total torque to rotate must be greater than the pinion torque to rotate plus 10 in.lbs..

(4) The differential total torque to rotate must be less than the pinion torque to rotate plus 13 in.lbs. for axles equipped with a standard differential. On axles equipped with a Vari-Lok™ differential, the differential total torque to rotate must be less than the pinion torque to rotate plus 18 in.lbs..

(5) If the differential total torque to rotate is within these guidelines, assemble the remainder of the axle.

(6) If the differential total torque to rotate is less than the required value, increase the shim thickness on the ring and pinion gear sides of the differential equally.

(7) If the differential total torque to rotate is greater than the required value, decrease the shim thickness on the ring and pinion gear sides of the differential equally.

(8) Remeasure the differential total torque to rotate.

ADJUSTMENTS (Continued)

GEAR CONTACT PATTERN ANALYSIS

The ring gear and pinion teeth contact patterns will show if the pinion depth is correct in the axle housing. It will also show if the ring gear backlash has been adjusted correctly. The backlash can be adjusted within specifications to achieve desired tooth contact patterns.

(1) Apply a thin coat of hydrated ferric oxide, or equivalent, to the drive and coast side of the ring gear teeth.

(2) Wrap, twist, and hold a shop towel around the pinion yoke to increase the turning resistance of the pinion. This will provide a more distinct contact pattern.

(3) Using a boxed end wrench on a ring gear bolt, rotate the differential case one complete revolution in both directions while a load is being applied from shop towel.

The areas on the ring gear teeth with the greatest degree of contact against the pinion teeth will squeeze the compound to the areas with the least amount of contact. Note and compare patterns on the ring gear teeth to Gear Tooth Contact Patterns chart (Fig. 90) and adjust pinion depth and gear backlash as necessary.

ADJUSTMENTS (Continued)

<p>DRIVE SIDE OF RING GEAR TEETH</p> <p>HEEL TOE</p> 	<p>COAST SIDE OF RING GEAR TEETH</p> <p>TOE HEEL</p> 	<p>DESIRABLE CONTACT PATTERN. PATTERN SHOULD BE CENTERED ON THE DRIVE SIDE OF TOOTH. PATTERN SHOULD BE CENTERED ON THE COAST SIDE OF TOOTH, BUT MAY BE SLIGHTLY TOWARD THE TOE. THERE SHOULD ALWAYS BE SOME CLEARANCE BETWEEN CONTACT PATTERN AND TOP OF THE TOOTH.</p>
		<p>RING GEAR BACKLASH CORRECT. THINNER PINION GEAR DEPTH SHIM REQUIRED.</p>
		<p>RING GEAR BACKLASH CORRECT. THICKER PINION GEAR DEPTH SHIM REQUIRED.</p>
		<p>PINION GEAR DEPTH SHIM CORRECT. DECREASE RING GEAR BACKLASH.</p>
		<p>PINION GEAR DEPTH SHIM CORRECT. INCREASE RING GEAR BACKLASH.</p>

Fig. 90 Gear Tooth Contact Patterns

SPECIFICATIONS

226 RBA AXLE

DESCRIPTION	SPECIFICATION
Axle Type	Semi-Floating Hypoid
Lubricant	SAE Thermally Stable 80W-90
Lubricant Trailer Tow	Synthetic 75W-140
Lube Capacity-w/o Vari-lok™	2.24 L (4.75 pts.)
Lube Capacity-w/ Vari-lok™	2.25 L (4.75 pts.)
Friction Modifier-w/ Trac-lok™	0.11 L (0.25 pts.)
Friction Modifier-w/ Vari-lok™	0.09 L (0.19 pts.)
Axle Ratios	3.55/3.73
Differential Bearing Preload	0.0127 mm (0.0005 in.)
Differential Side Gear Clearance	0-0.15 mm (0-0.006 in.)
Ring Gear Diameter	226 mm (8.9 in.)
Ring Gear Backlash	0.13-0.20 mm (0.005-0.008 in.)
Pinion Std. Depth	109.52 mm (4.312 in.)
Pinion Bearing Preload-New Bearings	2.8-4 N·m (25-35 in. lbs.)
Pinion Bearing Preload-Original Bearings	1-2 N·m (10-20 in. lbs.)
Maximum Carrier Spread	0.51 mm (0.020 in.)

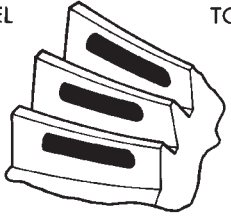
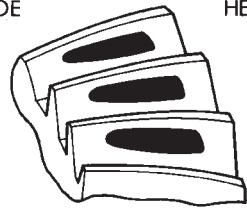
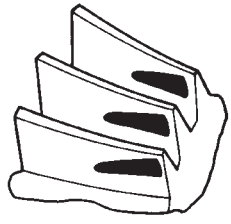
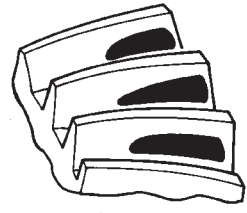
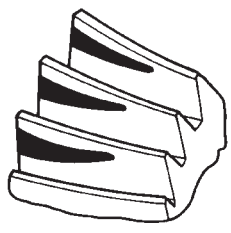
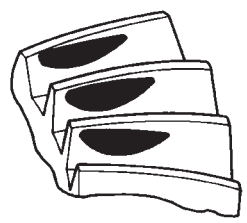
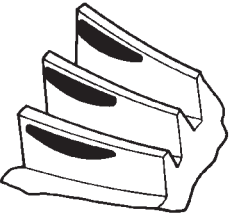
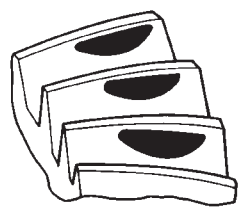
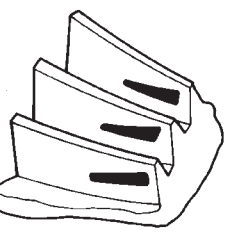
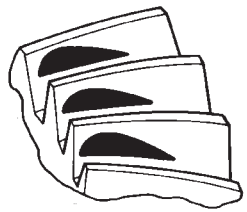
226 RBA AXLE

DESCRIPTION	TORQUE
Bolts, Diff. Cover	41 N·m (30 ft. lbs.)
Bolts, Diff. Bearing Cap	85 N·m (63 ft. lbs.)
Bolts, Ring Gear	108 N·m (80 ft. lbs.)
Screw, ABS Sensor	8 N·m (70 in. lbs.)
Screw, Pinion Gear Mate Shaft Lock	17.6 N·m (13 ft. lbs.)
Nuts, Axle Bearing Retainer Plate	61 N·m (45 ft. lbs.)
Nut, Pinion Gear—Minimum *	298 N·m (220 ft. lbs.)
Nut, Pinion Gear—Maximum *	380 N·m (280 ft. lbs.)

NOTE: *Refer to Pinion Gear Removal and Installation procedures for proper pinion nut tightening instructions. Do not exceed 380 N·m (280 ft. lbs.) during collapsible spacer crushing procedure.

SPECIAL TOOLS

226 RBA AXLE

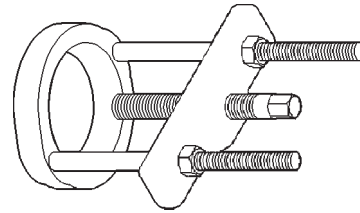

Puller Set—C-293-PA

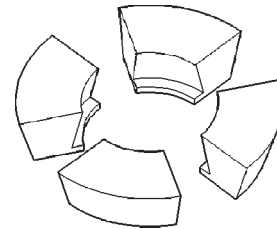

Adapter—C-293-42

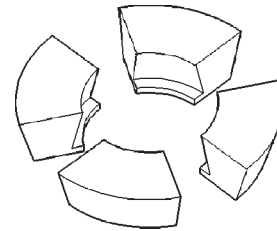

Adapter—8353

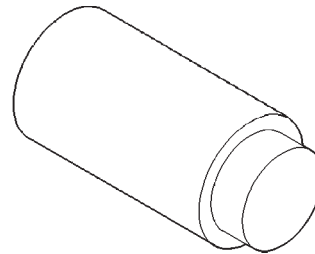

Extension—C-293-3

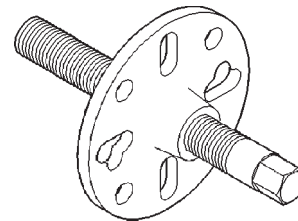

Remover—C-452

SPECIAL TOOLS (Continued)

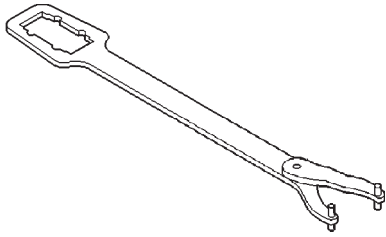

Holder—C-3281

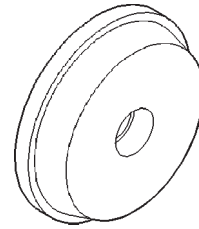

Installer—C-4308

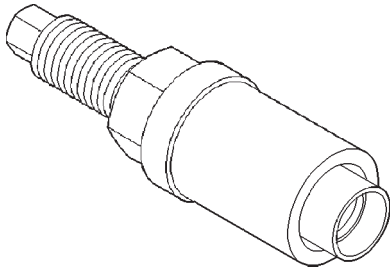

Installer—C-3718

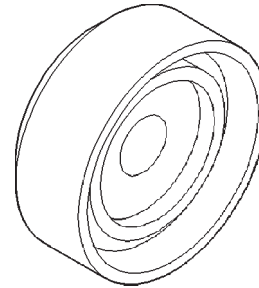

Installer—C-4340

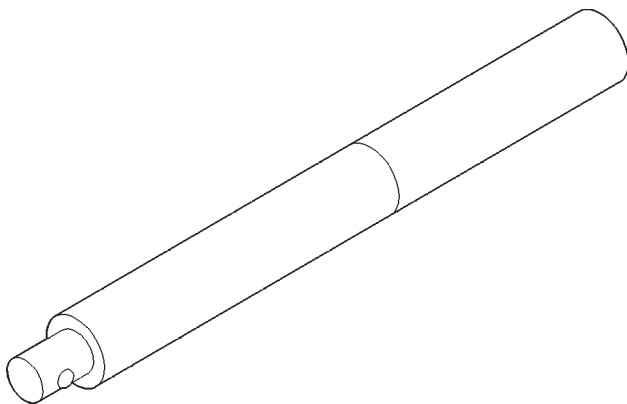

Handle—C-4171

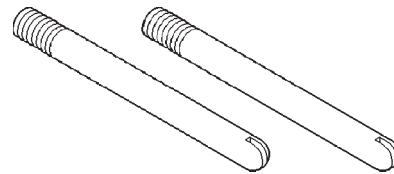

Guide Pin—C-3288-B

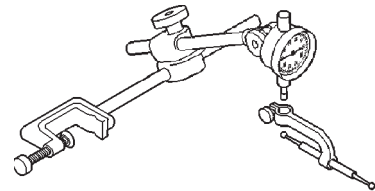

90116420

Dial Indicator—C-3339

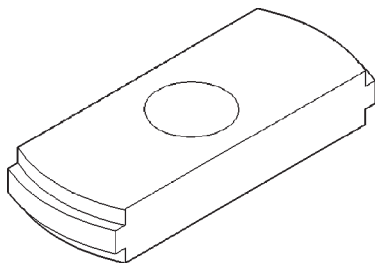

Remover—C-4307

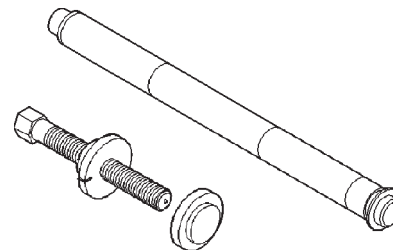

Trac-lok Tool Set—C-4487

SPECIAL TOOLS (Continued)

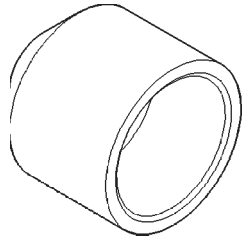

Installer—C-3972-A

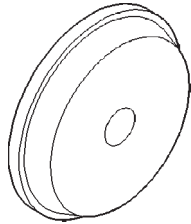

Installer—D-129

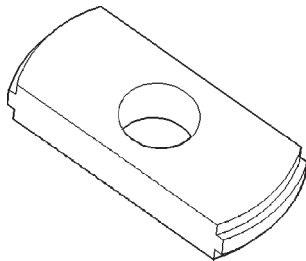

Remover—D-103

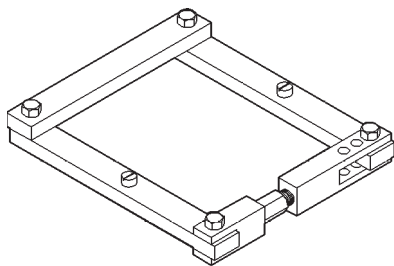

Spreader—W-129-B

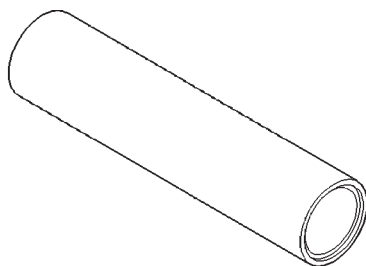

Installer—6448

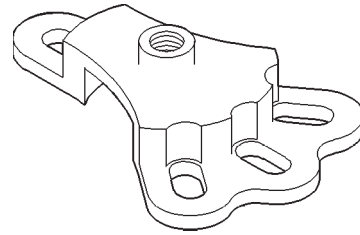

Adapter—6790

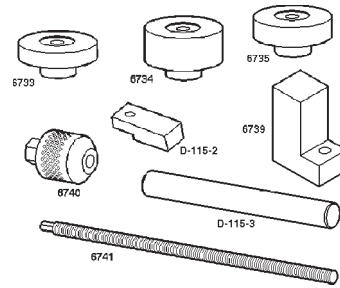

Pinion Depth Set—6955

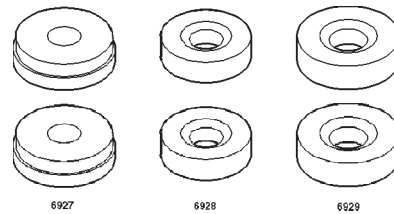

Adapter Set—6956

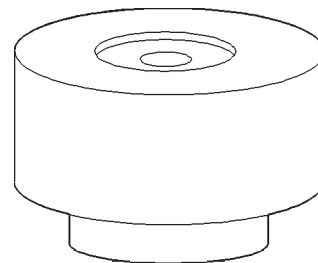

Gauge Block—8144

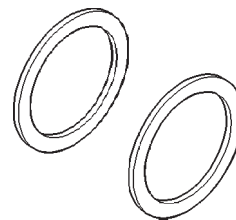

Starting Point Shim—8107

SPECIAL TOOLS (Continued)

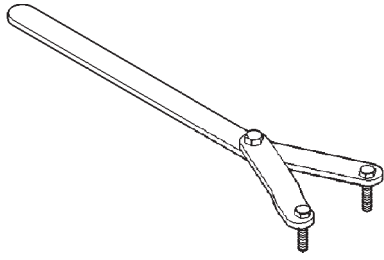

Holder—6958

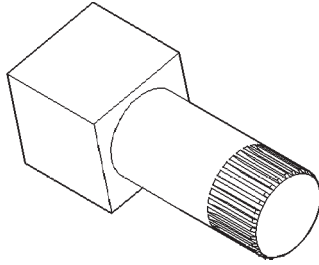

Holder—6963-A

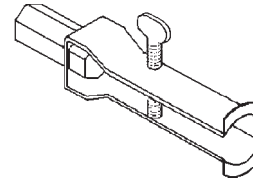

Remover—7794-A

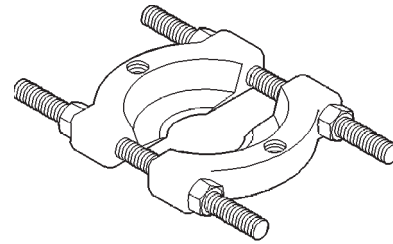

113C-00109ac3

Splitter, Bearing—1130

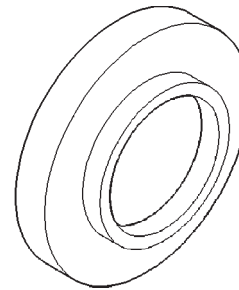

Installer, Gear/Bearing—7913-A